

CHAPTER FOUR

Structure Excavation

CONTENTS

| | |
|----------------------------------------------|------|
| INTRODUCTION | 4-2 |
| EXCAVATION EQUIPMENT | 4-3 |
| EXCAVATION | 4-9 |
| General Requirements | 4-9 |
| Earth Excavation | 4-13 |
| Rock Excavation | 4-13 |
| DISPOSAL OF SURPLUS AND UNSUITABLE MATERIALS | 4-15 |
| Storage | 4-16 |
| General Disposal | 4-16 |
| Muck Disposal | 4-17 |
| Paving Materials Disposal | 4-17 |
| BACKFILLING | 4-19 |
| Equipment | 4-19 |
| Materials | 4-22 |
| Testing | 4-25 |
| Preparations and Requirements | 4-28 |
| Placement and Compaction | 4-28 |
| ANSWERS TO QUESTIONS | 4-32 |

STRUCTURE EXCAVATION

INTRODUCTION

After the construction site has been staked, foundations on which the structures will rest must be constructed. As an Inspector, it will be your job to verify that the Contractor excavates all foundation pits according to the plan requirements. This is particularly important because foundations which are improperly constructed may result in settlement and damage to the structure, as shown in the diagram below.

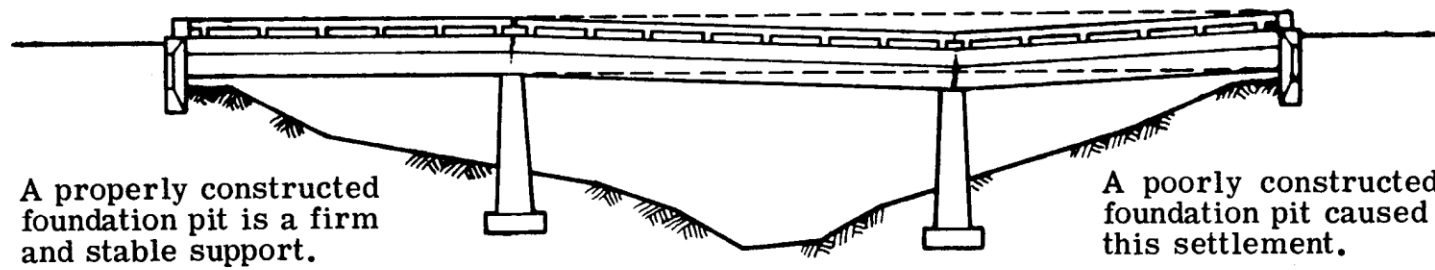

In this chapter, we will discuss the excavation work for structure foundations including excavation requirements, classification of materials, disposal of surplus materials, backfilling, and measurement and payment of excavation.

EXCAVATION EQUIPMENT

After staking has been completed, the areas where the foundation pits will be located must be excavated. The Contractor will use special equipment to excavate the site according to the plan requirements.

Before excavation begins, you should familiarize yourself with the equipment to be used. Let's look at some typical equipment that you will encounter.

- DRAGLINES are used for major excavation work. Drag lines and buckets are attached to the booms of light cranes. They have several parts with which you should be familiar -- so study the drawing on the next page.

An important part of the dragline is the bucket. Dragline buckets come in different weights and capacities. Softer materials are excavated with light buckets. Heavier buckets are used for rocky materials. Wet materials are excavated with perforated buckets.

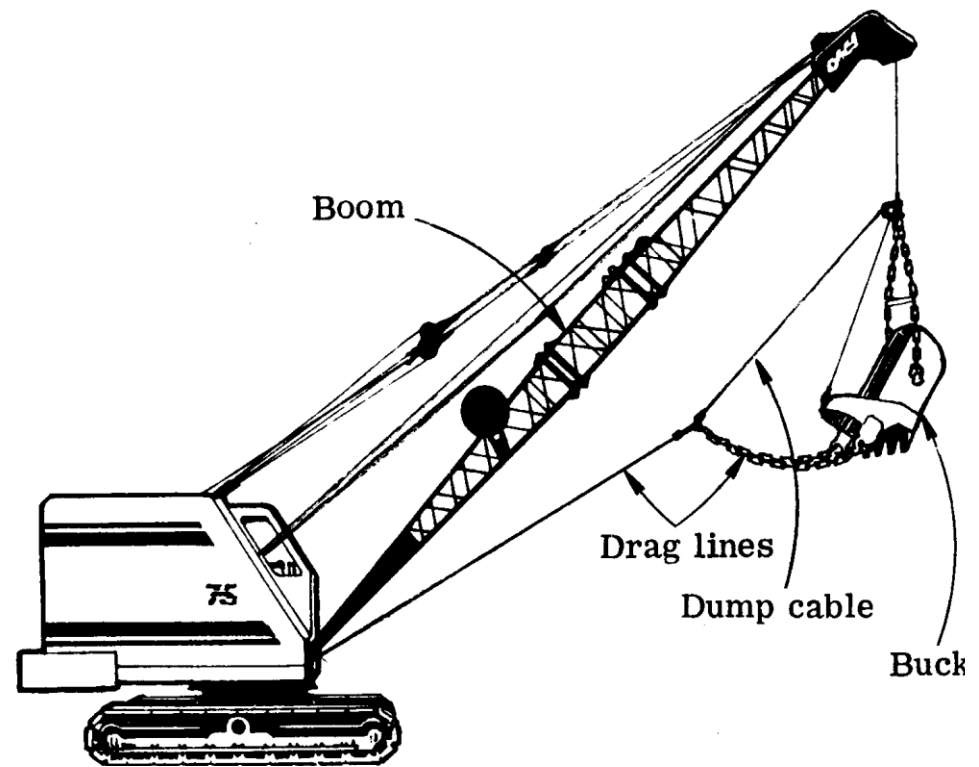

- Clamshells can be used in place of buckets on draglines. Clamshells consist of two jaws on a movable bar. This type of equipment is used for digging deep, narrow excavations with vertical sides.

Different weight clamshells are used for different soils -- similar to dragline buckets. Muddy or other wet materials are excavated with the lighter clamshells.

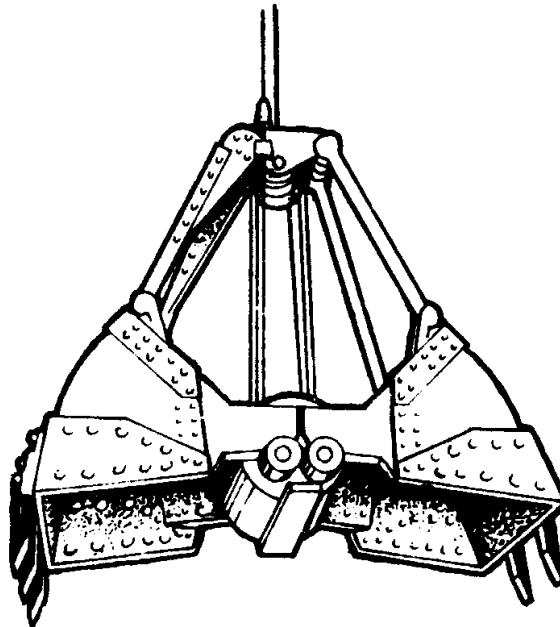

CLAMSHELL

- Backhoes are used for digging shallow vertical cuts into the soil -- such as for digging up and relocating utility lines. They are also used for excavation work for small culverts.

Backhoes are usually tractor-mounted with a hydraulically operated bucket attached to the rear, as shown below:

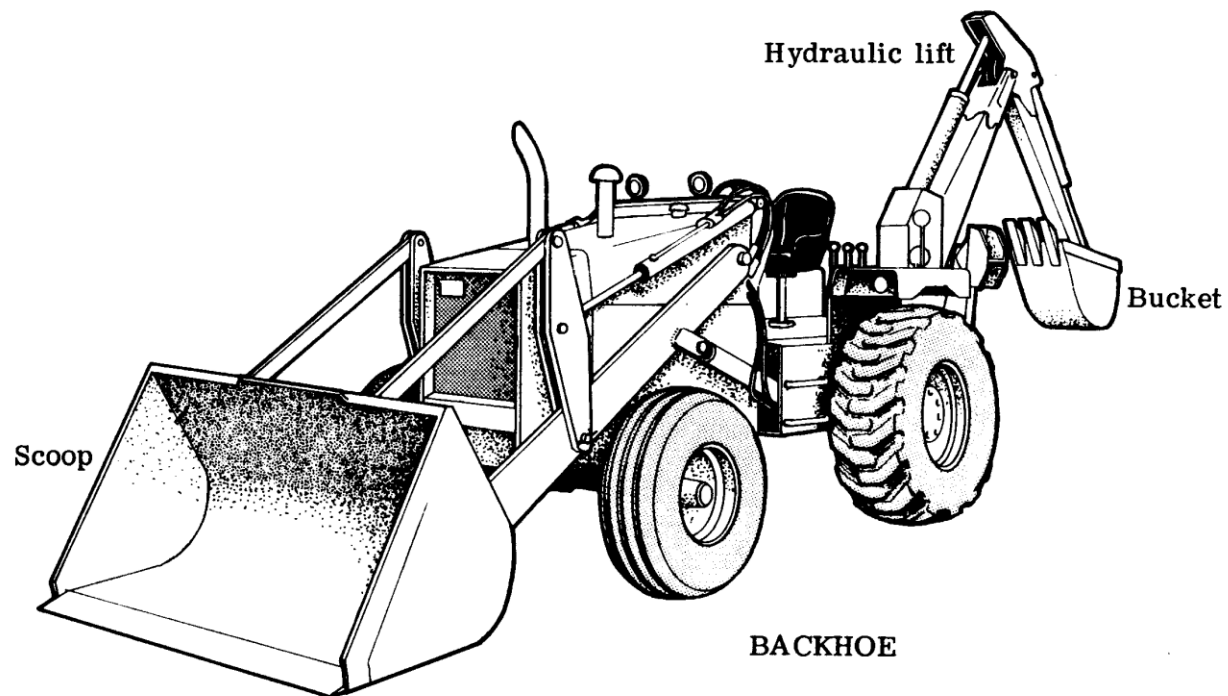

- Bulldozers are used for excavation in shallow, firm foundations, where a dragline is not needed.
- Bulldozers are particularly efficient for moving large quantities of material short distances. Generally, they are not used on unstable soil and muck.

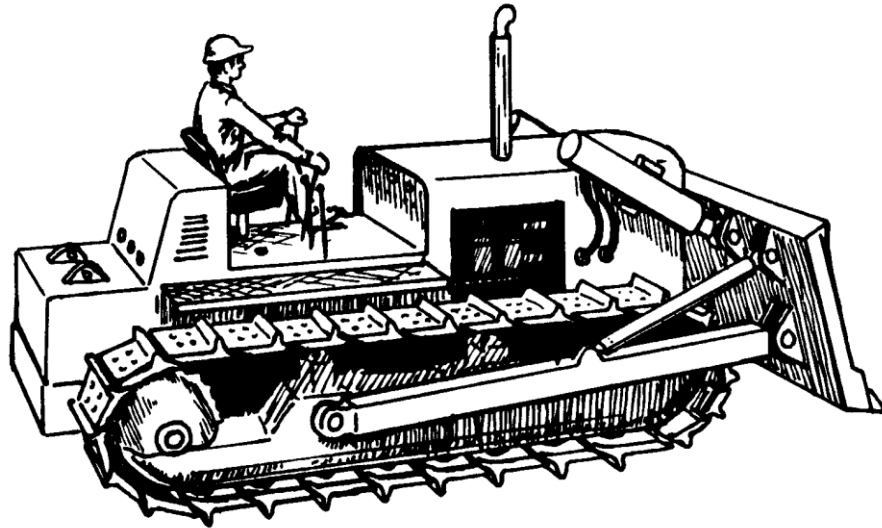

BULLDOZER

Try the quiz on the next page.

QUIZ

Excavation begins after _____ is completed.

What type of dragline bucket is used for excavating wet materials?

The type of crane used most for excavation work is called a _____.

What piece of equipment is used for digging shallow, vertical cuts in the soil?

Go on to EXCAVATION.

EXCAVATION

GENERAL REQUIREMENTS

Your job will be to verify that foundation pits are excavated so that footings can be constructed as shown in the plans. The pits must be wide enough and long enough to allow the footings to be placed. The pit dimensions must be larger than the actual footings so that people can work in the pit. In addition, the beds of the pits must be horizontal, so that there are no rounded or undercut corners on the footings.

The elevations of foundation pits will be shown on the plans, but the excavation must continue until satisfactory materials are encountered -- regardless of the plan excavation. Two situations have special requirements (ref Specification 125-4):

- Excavation in stream beds must continue to a depth of at least 4 feet below the permanent bed of the stream. If there is a danger of undermining, the excavation will need to be continued until a firm footing can be established.

There is one exception to this rule. If a firm footing can be established on solid rock before the excavation is 4 feet below the bed, then the excavation can be stopped.

- Whenever a rock bottom is secured, the Contractor must expose the solid rock and prepare the horizontal bed in it. This will involve removing all loose or disintegrating rock materials.

The dimensions of the pit must be large enough to allow the full placement of the footing.

The pit is excavated until suitable material is reached -- beyond the plan depth if necessary.

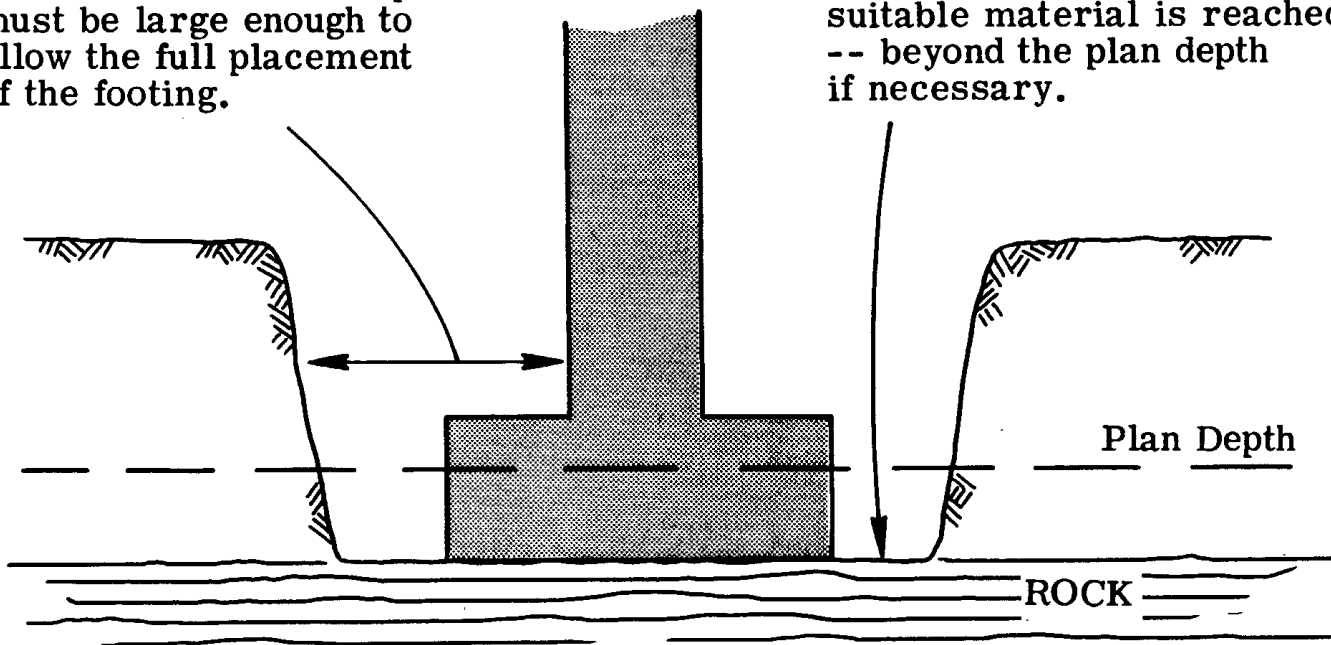

- If the material in place is suitable as a foundation, the foundation is graded to the elevation of the bottom of the footing. If the material in place is unsuitable, it is undercut, backfilled with select backfill material and compacted to the elevation of the bottom of the footing. The height of the backfill is controlled by stakes set at the working points.

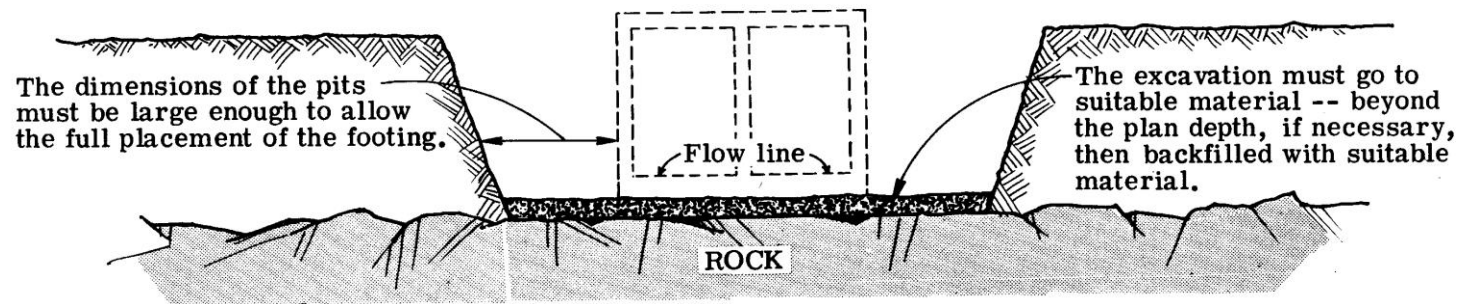

QUIZ

A properly constructed foundation pit will offer a firm and stable _____ for the structure.

In general, what is your job when inspecting footings excavation?

Under normal conditions, if the plans call for a 12-foot wide footing, should the excavation be 12 feet wide, or wider?

The plans show a foundation pit plan elevation of 5.00 feet, but muck is encountered at that depth. What should the Contractor do?

We have looked at the general excavation requirements, but there are particular requirements for earth and rock excavation. We will discuss these next.

EARTH EXCAVATION

Where rock is not encountered, the excavation is considered earth excavation. The general requirements apply, but there are some additional items you will have to inspect:

- Be sure that all boulders, logs or other obstructions are removed from the floor of the excavation.
- If the foundation material is soft or mucky, the Contractor may be required to excavate below the bottom of footing elevation and then backfill with suitable material. Be sure that the proper depth is reached and that the backfill material is approved.
- When piles are driven to provide support for the structure, be sure that the excavation of the pit is completed before pile driving and that all loose material is removed after pile driving.

The important point is this: the excavated bed must be smooth and level before the footings are placed. This is more likely to happen if excavation of the final few inches of soil as well as final preparation of the excavation bed is performed just before concrete placement.

ROCK EXCAVATION

Where rock is encountered, there are two important inspection items:

- The rock must be cleaned and cut to a firm foundation. This foundation may be level, stepped vertically or horizontally, or serrated -- as directed by the Engineer. Be sure you know the requirements.
- All seams that are encountered must be cleaned out and filled with mortar.

QUIZ

The excavation of a foundation pit includes excavation of muck and the replacement of it with suitable material. What are two important points you must ensure?

1. _____
2. _____

Foundation piles are to be driven to add support for the structure, but the Contractor wants to start pile driving before the plan grade is reached, claiming that he will clean up, smooth and level the pit later, when it can be done better. What is your response?

Rock is encountered during excavation and the Contractor wants to know if he should step or serrate the pit. How will you know what should be done?

Must seams be filled with Portland cement concrete?

If you did well on the quiz, go on to DISPOSAL OF SURPLUS AND UNSUITABLE MATERIALS. If you need to, go back and study EXCAVATION some more.

DISPOSAL OF SURPLUS AND UNSUITABLE MATERIALS

As we mentioned earlier, when unsuitable materials are excavated, they are replaced with suitable backfill. This will leave surplus materials when the backfilling is completed. These surplus materials remain in the ownership of the Department until the final job requirements for fill or backfill have been met then they become the property of the Contractor, unless otherwise provided for by the plans or special provisions. The Contractor is responsible for the disposal of these surplus materials.

There are some requirements for these materials that you should be aware of. There are requirements for:

- Storage
- General disposal
- Muck disposal
- Paving materials disposal

We will discuss each of these on the next pages.

STORAGE

Where practicable, the Contractor should temporarily stockpile materials in the right-of-way until the materials are declared surplus by the Project Administrator.

Where temporary storage in the right-of-way is impracticable -- such as in urban areas -- the Contractor has a couple of options:

- He may stockpile materials outside the right-of-way until the materials can be used or are declared surplus. If on private property, the Contractor must have a letter from the property owner giving him permission to use his property to stockpile material from the project.
- He may dispose of the materials, with the written approval of the Engineer. In this case, the Contractor will be required to replace the materials if the need arises later.

GENERAL DISPOSAL

If surplus materials are muck or other unsuitable materials, they must be disposed of as shown in the plans. If the plans do not show disposal locations, then they must be disposed of outside the right-of-way, in disposal areas provided by the Contractor.

MUCK DISPOSAL

As an exception to the general disposal requirements, muck may be placed on the side slopes in the following situations:

- The Engineer must approve the work.
- In rural undeveloped areas muck may be placed on the slopes, or may be stored alongside the roadway, provided there is a clear distance of at least six feet between the roadway grading limits and the muck, and the muck is dressed neatly. (Ref. Specification 120-5.2)
- In developed areas, the disposal must result in a pleasing appearance and have no harmful effect on the adjacent developments.
- The disposed muck must not interfere with channels or side ditches. The Project Administrator will know the allowable limits of muck disposal.

PAVING MATERIALS DISPOSAL

Unless otherwise indicated in the plans, paving materials excavated in the removal of existing roadways, such as paving brick, asphalt pavement, concrete slab, limerock, sidewalk, curb and gutter, etc. become the property of the Contractor and must be disposed of outside the right-of-way. If the materials are to remain the property of the Department, they must be placed in neat piles as directed.

Areas provided by the Contractor for disposal of removed paving materials, must be out of sight of the project and at least 300 feet from the nearest roadway right-of-way line of any State-maintained road. The 300-foot limitation will not apply, however, if the materials are buried.

QUIZ

Temporary storage of possible surplus materials should be _____ the right-of-way where practicable, and _____ the right-of-way where not practicable.

Declared surplus materials may be disposed of only when the _____.

If surplus materials must be disposed of, where should you look to find the requirements for the location and method of disposal?

If you do not find disposal areas in the above document, what must the Contractor do?

If muck may be placed on slopes, how far from the roadway grading limits must it be?

Paving materials must be disposed of at least _____ feet (meters) from the nearest right-of-way line, unless the materials are _____.

BACKFILLING

Backfilling is the operation of placing and compacting materials around bridge footings and around box culvert barrels and wing walls. Of course, footings are constructed long before any backfilling is done; but since backfill is basically a foundation operation, we will discuss it here. This section will cover all phases of backfill operations, including equipment, materials, special preparations, placement, compaction and payment.

EQUIPMENT

Two types of equipment used for backfill operations are loaders and compactors.

- Loaders are used to place backfill in the excavation. They are similar to backhoes, except they have a scoop mounted on the front. In fact, sometimes the same tractor is used for both.

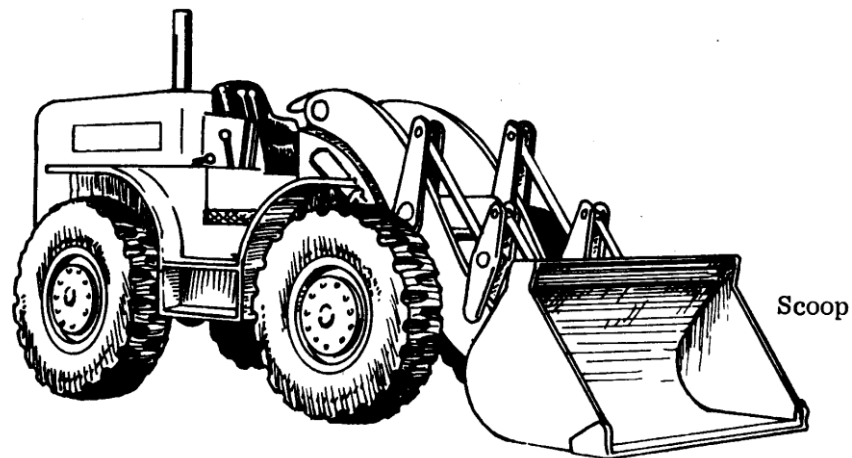

FRONT-END LOADER

- Compactors are just what the name implies. They compact the soil in layers as it is placed in the excavation.

Many types of power compactors are commonly used to compact backfill layers. A hand-held gasoline-powered tamper is shown at right. The foot of the tamper vibrates up and down to compact the soil.

Where space permits, backfill may be compacted with rollers. Rollers may not be used immediately behind MSE walls. A typical roller is shown on the following page.

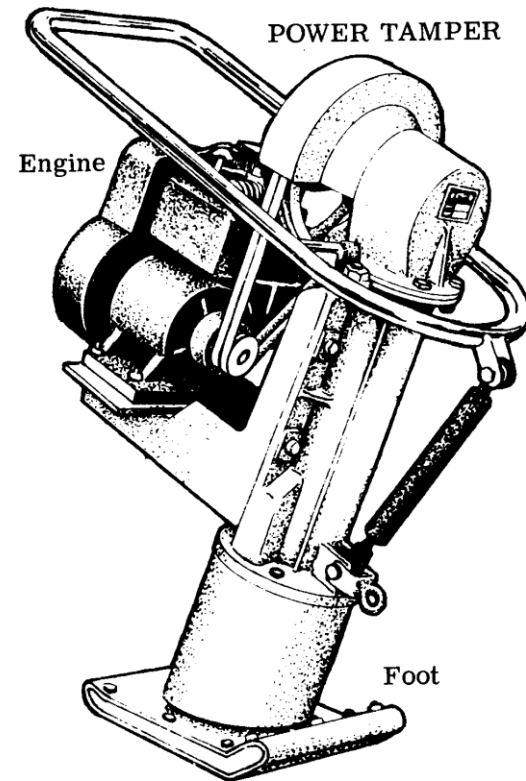



As an Inspector, you should become familiar with all compaction equipment used in backfill operations.

MATERIALS

The materials used to fill excavations can be called ordinary backfill and select backfill.

- Ordinary backfill is soil taken from the structural excavations or from a nearby road excavation. It should be free of lumps and foreign materials such as wood, weeds and trash. Ordinary backfill must be obtained from the various classes of granular material. When compacted properly, suitable granular material will not settle with time. Bumps at the ends of bridges commonly are caused by such settlement of backfill materials behind bridge abutments. For ordinary backfill, the best materials to use behind bridge abutments are mixtures of sand and gravel. Besides resisting settlement, these materials are strong and provide good drainage.
- Select backfill is used where there are special drainage requirements. For example, select backfill commonly is used behind abutments, to replace muck in cofferdams or to correct unstable conditions. Select backfill is usually hauled to the construction site by the Contractor. It may be composed of clean river sand, crushed rock, crushed gravel, or other suitable materials -- and be uniformly graded. Of course, like ordinary backfill, select backfill must be free of lumps and foreign materials. A photograph of well graded sand is on the following page.



Well Graded Sand

QUIZ

Backfilling is the operation of _____ and _____ material around bridge footings and box culvert barrels and wingwalls.

What equipment is used in the following backfill operations?

placement:

compaction:

Backfill materials must be free of _____ and _____.

When is select backfill used?

Select backfill may be composed of _____, _____,
or a _____.

TESTING

Backfill is tested as it is being placed for moisture content and density to ensure that it meets specified compaction requirements. Samples for soil classification may be required from select backfill and submitted to the District Laboratory for testing. You may not be responsible for actual testing, but you are responsible for seeing that tests are performed and that results are recorded. In other words, you must "follow up" on any testing that you have requested.

Soil Compaction

The term "compaction" refers to increasing the density or the unit weight of a soil mass by artificial means such as rolling, tamping or vibrating. The density of a soil is measured in terms of its weight per unit volume and usually is expressed in pounds per cubic foot of soil.

The backfill around structures must be compacted to a density of not less than 100% of the maximum density determined by the District Laboratory.

There is an exception to this requirement. When the backfill must be placed in water, hand tampers may be used with backfill material that compacts well underwater such as sand. When the hand tamped backfill reaches a level above the water that will allow the use of a mechanical compaction device, then one of these devices must be used until the previously hand tamped areas are compacted as well as possible. The soil above the water must meet the 100% density requirement previously mentioned.

Moisture-Density Relationships

There are several factors that influence the value of density obtained by compaction. These factors are of primary importance:

- The moisture content of the soil
- The nature of the soil -- that is, its gradation and physical properties
- The type and amount of compactive effort

For given moisture content and a given compactive effort, a soil will have a corresponding density. This is important, because a soil's structural properties vary with moisture content and density. For example, a clay soil at low density will have a relatively high load-carrying capacity when dry, but a relatively low load-carrying capacity when saturated.

Consequently, when a soil's structural properties are being determined, its moisture content and density must be defined and controlled -- in order to permit an accurate evaluation of the soil in that particular condition.

These facts about the moisture-density relationship can be learned by comparing the moisture-density test results of soils of many types. For more information concerning moisture-density, consult the Earthwork Training Course.

QUIZ

Backfill is tested for _____ and _____ to ensure that it meets specified compaction requirements.

In what terms is density usually measured?

Which of the following are primary factors that influence compaction?

- A. the nature of the soil; gradation and physical properties
- B. the type and amount of compactive effort
- C. the temperature of the soil
- D. the moisture content of the soil

Backfill must be compacted to a density of at least _____.

PREPARATIONS AND REQUIREMENTS

Before actual backfill operations begin, there are several preparations to be made and requirements to be observed:

- Backfill should not be placed against any newly constructed masonry or concrete structures until the structure has been in place for a minimum of 7 days.
- Backfill next to a structure must be placed on a solid foundation. Before any material is placed, you should be sure that all forms, loose material and rubbish have been removed from the foundation area.

PLACEMENT AND COMPACTION

All excavated spaces not occupied by abutments, piers or other structures must be backfilled to the surface of the surrounding ground, thoroughly compacted and neatly graded.

The backfill should be deposited in loose layers not more than 6 inches deep, as soon after the removal of forms as possible. If hand tampers are being used, it is good practice to keep layer thicknesses at 4 inches or less. The depth of the backfill layers is a common area of noncompliance. So, as an Inspector, you should be especially aware of this requirement.

Each layer must be compacted thoroughly before the next layer is started. Also, the moisture content of the material should be adjusted so that the material can be compacted to the required density. When conditions are wet, and with approval by the Project Administrator, granular material that compacts well in a wet condition can be used with a hand tamper until the backfill is up to a level dry enough to use a mechanical tamper.

When backfill is being placed around or over an arch or a rigid-frame structure, the material must be kept at the same

level on both sides of the structure in order to prevent unbalanced loading. This procedure and the problems that may result if it is not followed are illustrated on the next page.

The reason for backfilling layers alternately on both sides of a structure is demonstrated below. The circled numbers indicate the sequences in which the layers are backfilled.

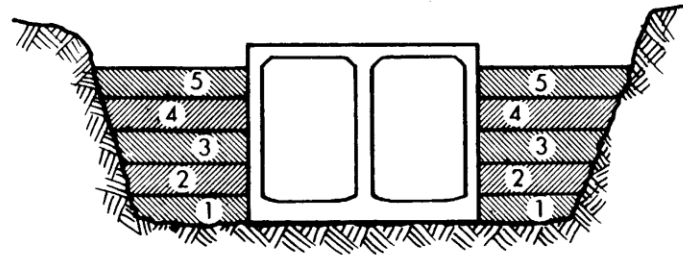

Uniform backfilling helps support the structure.

Uneven backfilling can shift or even topple a box culvert and can cause overstressing.

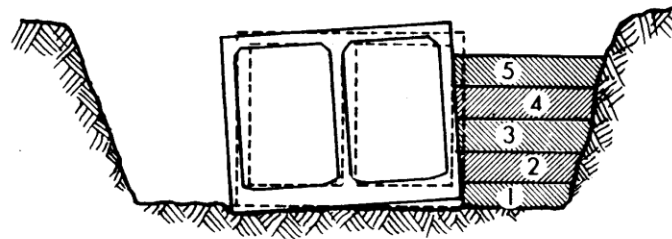

Where limited areas need to be compacted, hand tampers must be used until the cover is at least one foot above the structure. These hand tampers are restricted to a maximum face area of 100 square inches.

If any part of the structure is to function as a retainer for backfill -- such as abutments, retaining walls, wingwalls, arches, or minor structures -- the boundary slopes should be stepped in order to prevent any wedge action. Wedge action puts extreme lateral pressure on the structure and may cause it to topple or shift in position. The top surface of compacted backfill must be level -- or slightly sloped -- to drain adequately. In other words, there should be no ruts or depressions that will catch and hold water on the backfill surface.

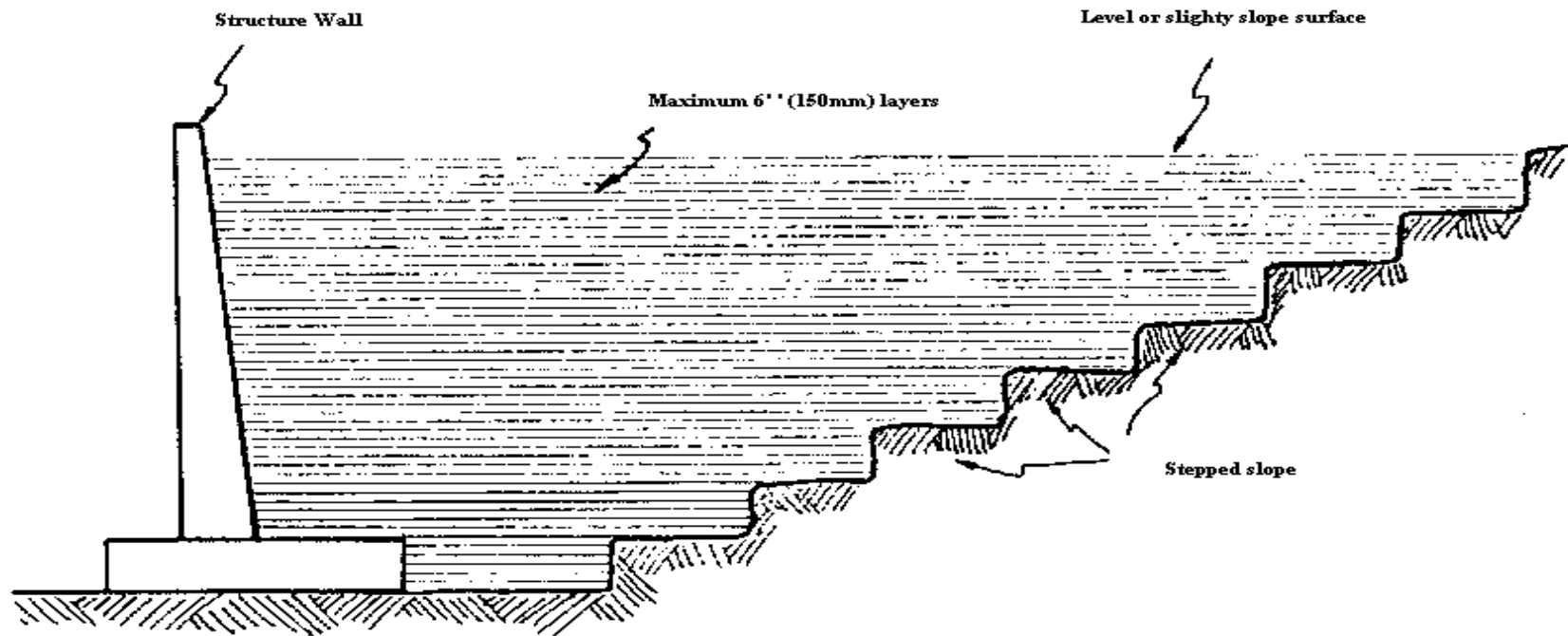

QUIZ

If an equal amount of backfill is not placed and compacted alternately on both sides of the walls of a structure, what could happen to the structure?

Structural Contractors are responsible for backfilling excavations to the level of the _____.

In limited areas, hand tampers are used until the cover is _____ above the structure.

How thick should the loose layers of backfill be when rollers are used to compact?

Who is responsible for the removal of rubbish, forms and loose material in the excavation?

What is good practice thickness for the loose layers of backfill when hand tampers are being used?

What should be done to the boundary slopes adjacent to parts of structures that function as retainers for backfill?

When muck disposal may interfere with channels or side ditches, where will you find out the allowable limits of disposal?

Name three factors which influence the value of density obtained by compaction.

ANSWERS TO QUESTIONS

Page 4-8

- staking or layout
- perforated
- dragline
- backhoe

Page 4-12

- support
- ensure that pits will contain the entire footing
- wider
- excavate to firm, satisfactory material

Page 4-14

- 1. proper depth, 2. approval of material
- excavation should be complete before driving
- check with the Project Administrator
- no, with mortar

Page 4-18

- Inside, outside
- Engineer approves
- plans
- dispose of material outside the right-of-way
- 6 feet
- 300ft, buried

Page 4-24

- placing, compacting
- front-end-loaders, power tampers
- lumps, foreign materials
- when special drainage requirements must be met

- crushed rock, crushed gravel, crushed slag, combinations of these

Page 4-27

- moisture content, density
- pounds per cubic foot
- A, B, D
- 100% of maximum density

Page 4-31

- it could be shifted out of position of toppled
- original ground
- at least 1 foot
- 6 inches
- Contractor
- 4 inches
- they should be stepped
- from the Project Administrator
- the moisture content of the soil
- the moisture of the soil
- the type and amount of compactive effort