

# **STRUCTURES INSPECTION SELF STUDY TRAINING COURSE**

**PART TWO  
2012**



**STATE CONSTRUCTION OFFICE**

This 2012 update was produced by Dan L. Hurtado, P. E., Construction Structures Engineer

# FOREWORD

Structures Inspection is a training course in two parts. The course covers most of the inspection activities that are necessary to ensure that proper quality control is performed during the construction of structures.

The inspection activities discussed in Part One of this course include:

- Office and field preparations
- Staking procedures
- Structure foundation inspection, including excavation and backfilling
- False work and forms
- Reinforcement
- Documentation

Part Two (superstructures) covers the following topics:

- Beams and Girders in General
- Erection of Steel Beams and Girders
- Erection of Precast Concrete Beams and Girders
- Deck Construction
- Barrier Walls
- Miscellaneous Construction
- Painting

# TABLE OF CONTENTS

## PART THREE

Foreword .....	ii
Directions to Course Users .....	iv
Chapter One: BEAMS AND GIRDERS IN GENERAL .....	1-1
Chapter Two: ERECTION OF STEEL BEAMS AND GIRDERS.....	2-1
Chapter Three: ERECTION OF PRECAST CONCRETE BEAMS AND GIRDERS .....	3-1
Chapter Four: DECK CONSTRUCTION .....	4-1
Chapter Five: BARRIER WALLS .....	5-1
Chapter Six: MISCELLANEOUS CONSTRUCTION .....	6-1
Chapter Seven: STRUCTURAL STEEL PAINTING .....	7-1
Chapter Eight: REVIEW QUIZ .....	8-1

# **DIRECTIONS TO COURSE USERS**

## **TRAINING TECHNIQUE**

This course has been designed for self-instructional training:

- You can work alone.
- You can make as many mistakes as are necessary for learning -- and correct your own mistakes.
- You can finish the training at your own speed.

## **PREREQUISITES**

For Structures Inspection -- Part Two, you will need to successfully complete the following self study courses: Construction Mathematics and Contract Plan Reading. In addition, you should have completed two other training courses or know their subject matter thoroughly. These courses are: Portland Cement Concrete Testing; Placement and Control; and Structures Inspection -- Part One.

## HOW TO USE THESE BOOKS

These are not ordinary books. You cannot read them from page to page as you do other books. These books give you some information and then ask a series of questions about that information. The questions are asked in such a way that you will have to think carefully and draw some conclusions for yourself. If you have difficulty answering the questions, review the sections that give you trouble before going on. Where applicable, on the right hand side of the page, of the lesson heading line, there will be a reference to the Florida Department of Transportation Standard Specifications (SS) and/or Special Provisions (SP) for Road and Bridge Construction section that applies to the lesson. For example: Grooving [SS 400]. If you want to find out more about the lesson you are working on, read the Standard Specification or Special Provision that is referenced.

The answers to the questions are found at the end of each chapter. The answers to the Review Quiz are at the end of the quiz.

## EXAMINATION

Three Examinations have been developed for Structures Inspection -- one for each Part.

The Exam contains questions and problems only -- no answers. To help you prepare for the Examinations, Review Quizzes are included at the end of each Part. If you do well on the Review Quizzes, the Examinations will present no problems.

Together, the three Examinations comprise the Examination for the whole course. But you must pass the Examination for each Part before you begin the next Part.

# CHAPTER ONE

## ***BEAMS AND GIRDERS IN GENERAL***

### CONTENTS

<b><i>INTRODUCTION</i></b> .....	<b>1-2</b>
<b><i>LOCATING BEARINGS</i></b> .....	<b>1-6</b>
<b><i>ANCHOR BOLTS</i></b> .....	<b>1-7</b>
Setting Bolts in Drilled Holes .....	1-7
Setting Bolts in Formed Holes .....	1-7
<b><i>BEARING TYPES</i></b> .....	<b>1-10</b>
Non-composite Neoprene Bearings .....	1-10
Composite Neoprene Bearing Pads.....	1-11
Multirotational Bearings .....	1-13
<b><i>SETTING BEARINGS</i></b> .....	<b>1-14</b>
Checking Fabrication of Beams .....	1-14
Centerline of Bearing Adjustments .....	1-15
<b><i>ANSWERS TO QUESTIONS</i></b> .....	<b>1-20</b>

## ***INTRODUCTION***

The Contractor can begin the construction of the superstructure once the substructure of the bridge has met all strength and age requirements. The main elements of the superstructure include:

- The beams and girders, which transfer loads from the bridge deck to the substructure
- The bridge deck
- The barrier walls and railings

NOTE: The terms beams and girders may be used interchangeably. However, by definition, girders are larger, longer beams that are assembled by bolting or welding individual plates together instead of being rolled as one solid member (See Part 1, Chapter 1, for a review of bridge terminology).

As you know from Part 1, Chapter 1, the Department uses two beam material types: steel and concrete. The process of construction and erection of both beam material types is almost the same and the major phases are as follows:

- **FABRICATION** – Steel rolled beams are produced at a steel plant in standard sizes for use by any contractor that places an order. Steel girders, also called plate girders, are fabricated on a project by project basis from individual plates at a fabrication plant by welding or bolting plates together to form wide flange and box shaped members. After they are fabricated they are shipped to the project site. Concrete beams and girders are produced in a prestress plant or yard by constructing forms for the required girder shape then placing and stressing prestress strands in the forms and finally pouring concrete into the forms. Once the concrete hardens, the strands are released and the beam receives final curing after which it is ready to be shipped to the project site.





**Steel Plate Girders at a Fabrication Facility**

- **DELIVERY AND STORAGE** - Once the beams are delivered to the project site they must be stored properly and be inspected for fabrication defects and damage that may have occurred during transport to the project or as a result of handling at the site.
- **PLACEMENT AND ADJUSTMENT OF BEARINGS** - The beam bearings are placed on the substructure elements (bent, pier or abutment cap) in preparation for beam erection. The position of the bearings may require adjustment for temperature just prior to placement of the beam.
- **GIRDER PLACEMENT** - Steel rolled beams are lifted by crane and placed onto the bearings. Steel continuous plate girders are placed on the bearings and individual sections are bolted together while

being suspended by a crane or while being supported on temporary towers. Simple concrete beams are placed onto bearings by crane. Individual sections of continuous concrete girders are placed on pier bearings and on temporary tower bearings. The concrete for the joints between concrete girder sections is poured.

- **FINAL BOLT TIGHTENING AND STRAND POST-TENSIONING** - The bolts in steel girder splices receive final tightening. The steel strands for post-tensioned girders are stressed and anchored.
- **ASSEMBLY OF BRACING AND DIAPHRAGMS** - Once at least two beams or girders are placed on their bearings, the members that connect one beam to another, called bracing (steel beams) or diaphragms (concrete beams), are installed. For steel, bracing is often installed between two beams prior to erection for better stability during handling. When all bracing and diaphragms are complete, the deck can be constructed.

In the lessons that follow, these beam/girder erection phases will be covered in more detail. The initial sections will cover phases that are the same for both steel and concrete beam/girder superstructures followed by sections that deal specifically with one or the other material.

## **LOCATING BEARINGS**

The first step of bearing installation is locating the bearing areas on top of the substructure unit or cap. These areas are called pedestals or beam seats. Bearing areas on caps and abutments are located with survey methods from the original reference points outside the construction area. You should observe the Contractor's procedures for locating the bearing areas to be sure that the following things are done:

- The Contractor must not assume that the centerline of bearing is also the centerline of the cap. When beams from spans of different length bear on the same cap, the centerline of bearing is usually not at the centerline of the cap.
- Any deviations between the original survey and the actual structure location should be evaluated prior to the scribing of bearing areas. The definition of scribing is to mark the layout on a concrete surface.
- If any corrections are needed, you must check with the Project Engineer for the proper corrective methods. Then, you must be sure that the Contractor corrects any problems before beams are placed on the bearings.
- Elevations must be checked carefully.
- Bearing areas should be scribed onto the beam pedestals after being located and verified.

## **Q U I Z**

- 1) Bearings are placed on \_\_\_\_\_ or \_\_\_\_\_ .
- 2) True or false: the centerline of bearing is always the same as the centerline of the cap.
- 3) In order to insure that the bearing is positioned properly what must be done to the pedestal?

## **ANCHOR BOLTS**

[SS 460]

Anchor bolts are used to hold the bearing assembly in place on top of the pedestal and to produce a fixed bearing, which will be explained in a following lesson. There are two methods of setting anchor bolts: drilled holes or formed holes. Details for anchor bolt placement will be found in the plans and shop drawings.

### **SETTING BOLTS IN DRILLED HOLES**

In this method, which is seldom used, a vertical hole is drilled into the hardened concrete, the hole is thoroughly cleaned, grout is placed in the hole and the anchor bolt is pushed down through the grout. When this method is used, care should be taken to keep from cutting the reinforcing steel. To avoid hitting steel, and to make sure that the bolts will be placed properly, it is recommended that the Contractor use a bolt hole template. This method is usually more convenient than the formed hole method since the final position of the anchor bolt is known and because the drilling takes place shortly before beams are placed. Due to the risk of damaging the reinforcing steel, this method may only be used when specified in the Contract Documents.

After the bolt is in its final position, grout is placed in the bolt hole. Since the grout keeps the anchor bolt from pulling out of the cap concrete, it is very important that it be mixed and placed properly. The grout shall be a mixture of one part cement and one part clean fine sand that is wet enough to flow freely. A recommended procedure for curing the grout is, simply, to brush curing compound on the area.

### **SETTING BOLTS IN FORMED HOLES**

Holes that are 4 inches in diameter are formed in the concrete. This is accomplished by inserting a metal or plastic pipe, with an outside diameter of 4 inches, into the fresh concrete then withdrawing it once the concrete is partially set. This leaves the correct size opening in the concrete for the anchor bolt. It is important that you make sure that the hole is at least 4 inches in diameter since it is usually formed long before the final position of the anchor bolts is determined. This hole diameter will allow some extra room for establishing the anchor bolt's final position. Once the concrete has hardened the grouting procedure is the same as with drilled holes.



**Typical Neoprene Bearing Pad with Formed Bolt Holes (note the grout tubes protruding from the pedestal)**

This drawing shows a typical anchor bolt layout:

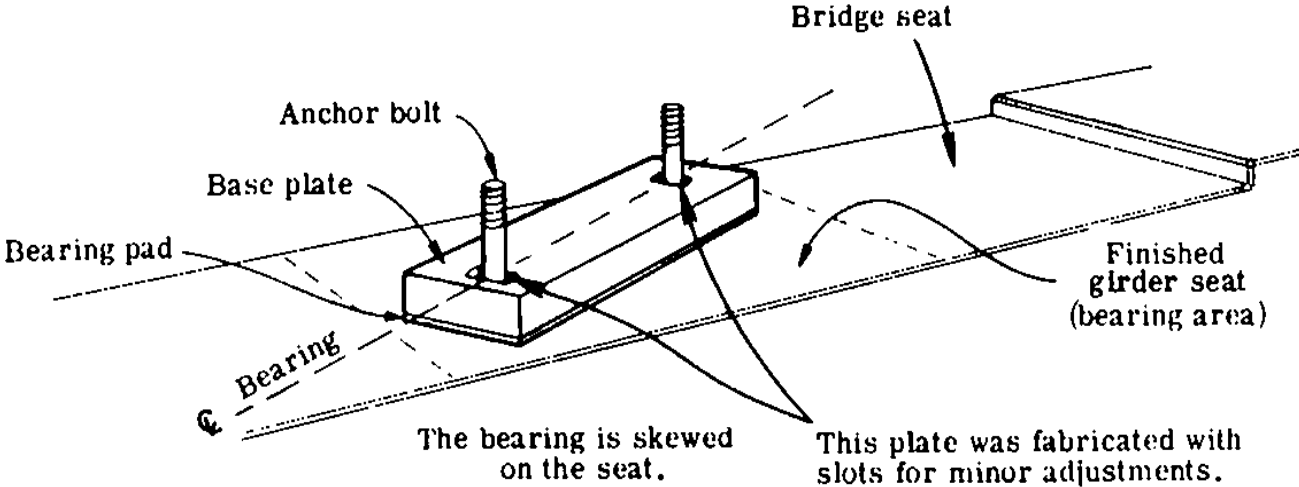

## Q U I Z

- 1) Where will you find details of anchor bolt placement?
- 2) Usually, anchor bolts are set into pier caps by \_\_\_\_\_ holes for the bolts and \_\_\_\_\_ them into place.
- 3) To make sure that the Contractor doesn't drill through rebars, it is recommended that a \_\_\_\_\_ be used.

## **BEARING TYPES**

Steel and concrete beams use the same types of bearings which fall into three major categories: non-composite neoprene bearings, composite neoprene bearing pads and multirotational bearings. Which type bearing is used, depends mostly on the length and curvature of the beam. Bearings function as either fixed or expansion. Fixed bearings permit rotation of the girder end but not lengthening (expansion) or shortening (contraction). Expansion bearings allow expansion and contraction as well as rotation.

The details of how to properly position the bearing on top of the pedestal will be discussed in a following lesson.

### **NON-COMPOSITE NEOPRENE BEARINGS**

These type bearings are used primarily for Flat Slab bridges and are formed of pure neoprene. The pads are positioned between the bottom of the slab and the top of the cap and are usually continuous from one end of the cap to the other. You will need to make sure that they are positioned correctly and that all material requirements comply with the specifications.

## **COMPOSITE NEOPRENE BEARING PADS**

Composite pads handle heavy loads from both steel and concrete beams/girders and this requires the pad to be manufactured with alternating layers of neoprene and steel (see illustration next page). The neoprene layers give the pad the flexibility needed to accommodate the expansion and contraction of the girders due to temperature variations as well as rotation of the end of the girder in the direction of the girder's length. The steel plates provide stiffness to prevent the neoprene from bulging and cracking. Plain composite pads accommodate the beam movement by deforming or changing shape, since there are no sliding elements. Pads come in standard sizes when they are intended for use under standard beams such as AASHTO or Bulb-T beams, but they are also ordered in custom sizes where a standard pad will not work.

For all but the longest girders, the pad is used without sliding steel elements. The amount of girder expansion / contraction or movement the pad can accommodate is directly related to its height: the higher the pad the greater the movement that can be accommodated. There is a limit to how high the pad can get; however, and when it is exceeded, the top of the pad is fitted with a steel external plate having a non-stick surface similar to Teflon or TFE (see illustration). To minimize friction between the girder and the bearing, a steel sole plate or bearing plate is attached to the bottom of the girder and is made of stainless steel with a polished surface. The stainless sole plate slides on the TFE surface, which allows the neoprene pad to accommodate more girder movement than it could by itself. Proper positioning of the pad is critical so you must observe how the Contractor does this very carefully. Remember, the pad must comply with all material specifications.

## EXAMPLE COMPOSITE NEOPRENE BEARING PAD

Cross section through the center of a 10" wide by 20" long Pad

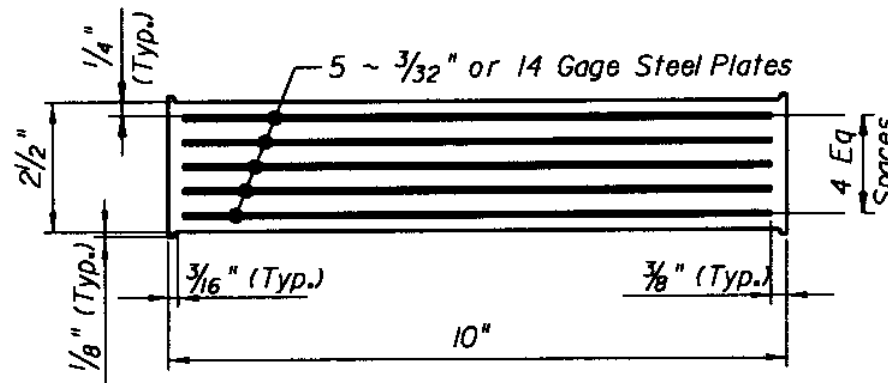

## EXAMPLE COMPOSITE NEOPRENE BEARING PAD WITH TFE TOP SURFACE

Cross section through the center of a 10" wide by 20" long pad

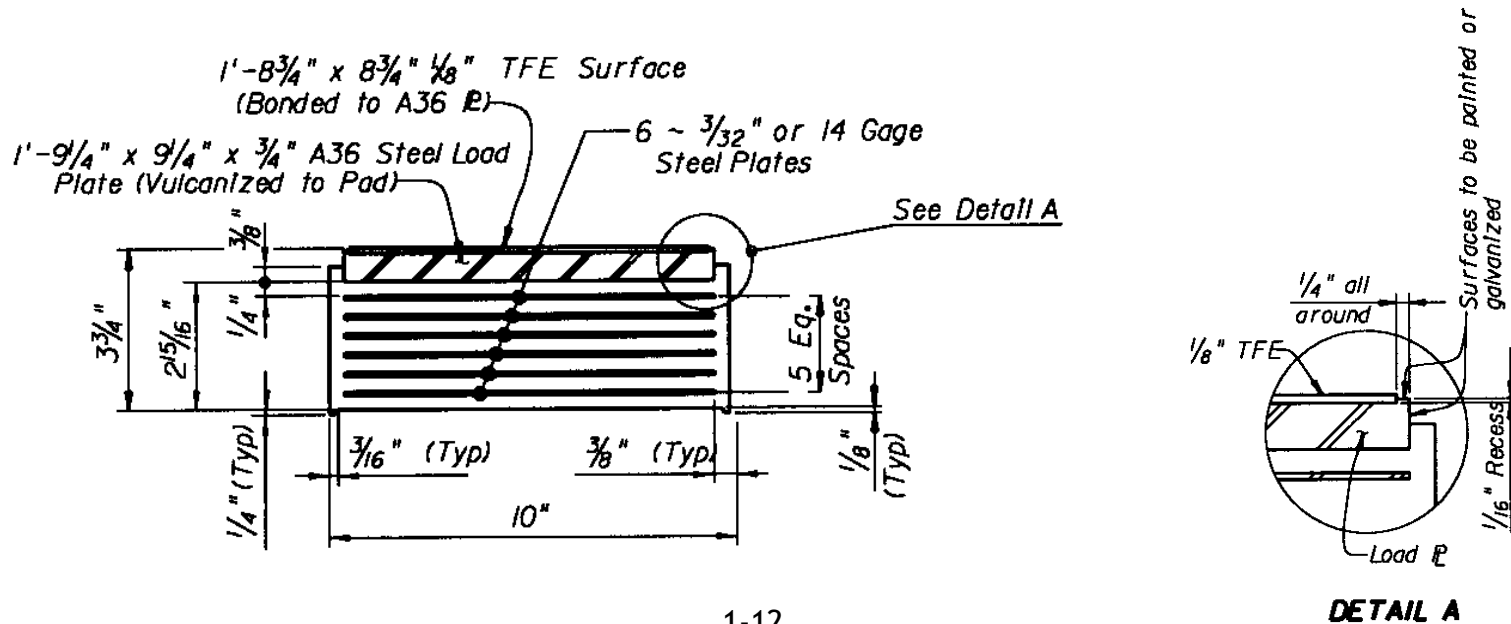

## MULTIROTATIONAL BEARINGS

These bearings are used for the longest girders and/or for curved girders. They can accommodate very large girder movements and rotation in any direction, not just in the direction of the girder's length. They are used as fixed bearings also, in which case they allow rotation in any direction but not expansion or contraction. There are two main types of multirotational bearings used by the Department: Pot Bearings and Disc Bearings.

Pot Bearings (see the illustration to the right) are by far the most commonly used and function with a piston and cylinder (or pot) type mechanism. The pot contains a neoprene like material that is confined within it. When the piston is inserted into the pot, it floats on top of the neoprene material and this allows it to rotate in any direction.

The disc bearing functions very much like a bearing pad but is a much tougher material and is capable of withstanding much higher loads as well as rotations in any direction. It is also confined by steel plates. As with the bearing pads, you must be sure that positioning is done properly and that materials comply with the specifications. Both type bearings use a steel bearing or masonry plate with slotted holes for anchor bolts to go through, in order to permanently fasten the bearing assembly to the concrete pedestal.

Prior to installation, Pot Bearings must be protected from the elements. Sliding surfaces and bearing mechanisms can be affected greatly by corrosion and contaminants.

## TYPICAL POT BEARING Expansion Type

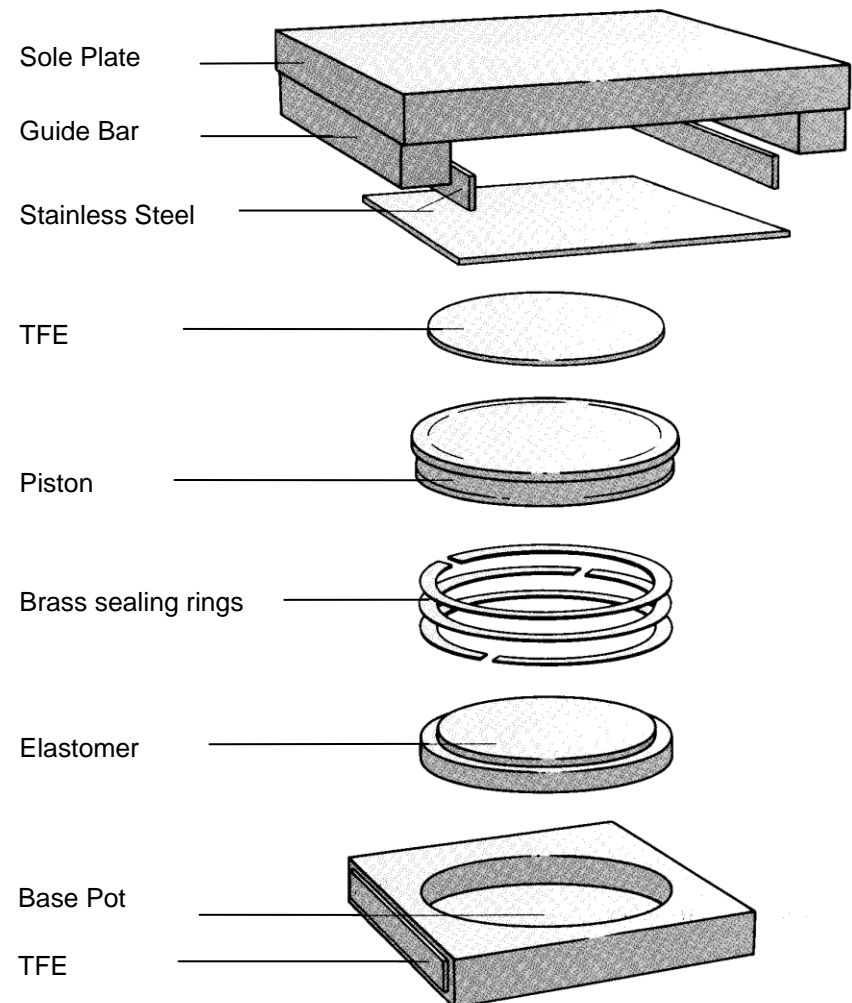

## Q U I Z

- 1) Name the three major types of bearings used by the Department.
- 2) Composite pads are made up of alternating layers of \_\_\_\_\_ for flexibility and \_\_\_\_\_ to prevent bulging.
- 3) True or false: fixed pot bearings can accommodate large expansion and contraction movements.

## **SETTING BEARINGS**

### **CHECKING FABRICATION OF BEAMS**

The way beams are fabricated is important. They must be checked against the shop drawings, as well as against actual field conditions. You should check for errors prior to construction in order to avoid unnecessary delays.

You should check the actual distances between the pier, bent or abutment pedestal centerlines and the distances between the bearing centerlines of the beam and the length of the beam while it is being stored. The shop drawings will show the centerline of bearing for the beams. When the beam ends are placed on the pedestals, the centerline of bearing for the beams must align as closely as possible to the centerline of bearing of the pedestals. For pedestals that have a bearing base plate on top, the centerline of bearing of the pedestal and base plate must be the same. For example, the diagram on the next page shows the various measurements that are used.

Bearing centerline spacing must be checked on each beam. This can be done upon delivery by matching the beams to the shop drawings. In most cases, the bearing centerlines are in the proper locations. But if they are not, major problems can arise. So be sure to check them.

## CENTERLINE OF BEARING ADJUSTMENTS

If the locations of bearing centerlines on the beams are not within the tolerances noted on the shop drawings or standard specifications, the bearing areas on the pedestals may need to be adjusted to fit the bearing centerline spacing of the beams. If the beam bearing centerline locations are within the tolerances, the bearing areas on the pedestals need not be adjusted. The longer the beam the more critical is this process since the magnitude of the expansion and contraction increases with beam length. Also, the positioning of neoprene pads that do not have sliding plates is less precise, due to a much greater margin for error and the fact that they cannot be adjusted for temperature. For these type pads, the centerline of the pad just needs to coincide with the centerline of bearing of the pedestal.

This diagram shows the measurements you will need to determine the correct bearing locations.

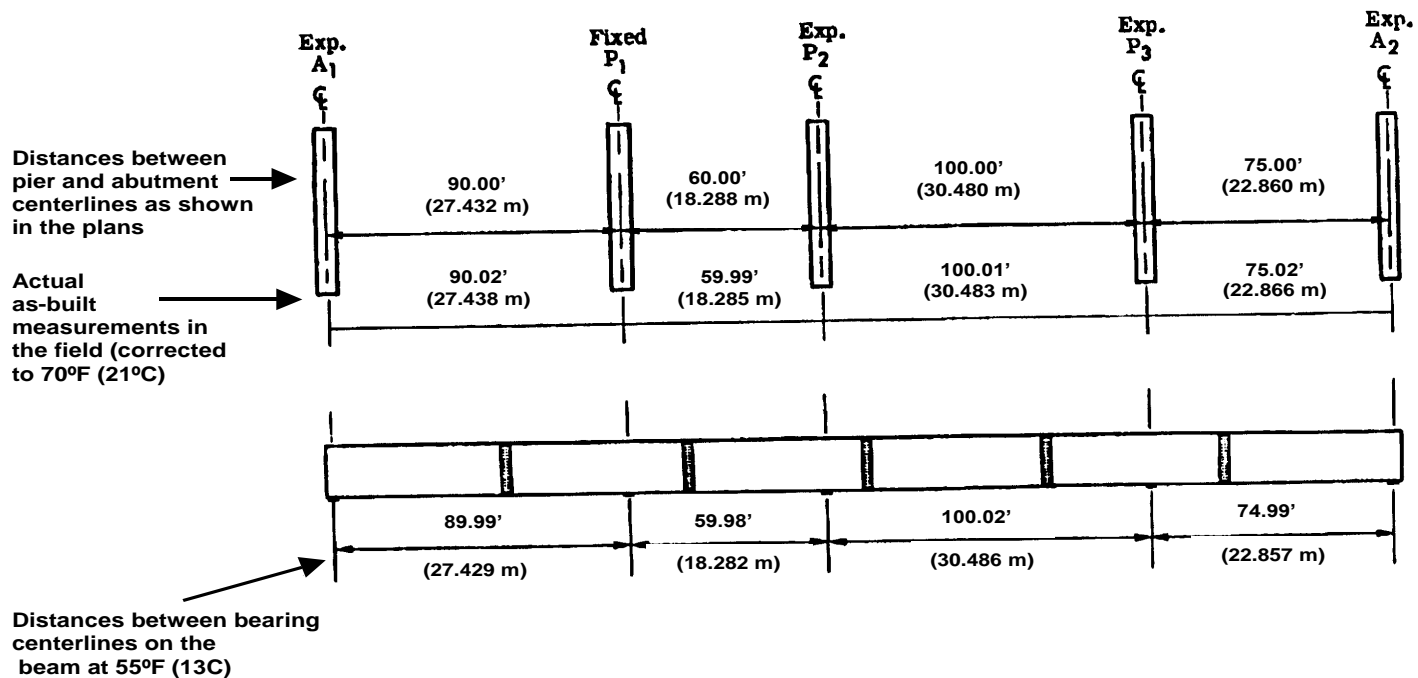

In the diagram on the previous page, the distances between pier centerlines and beam bearing centerlines vary. To make the proper adjustments on the beam pedestals, you must:

1. Determine beam bearing centerline spacing at 70° F.
2. Compare spacing at 70° F to pier, bent or abutment centerline spacing, by calculating the differences in the spacing.
3. Be sure that the proper corrections are made. We will discuss the options open to the Contractor in the text ahead.

Now, look at each step in detail, beginning below.

- 1) The following rule of thumb is used in determining the amount of expansion and contraction in steel. For concrete girders, consult your Project Engineer:

Expansion or contraction = 1/8 inch per 100 ft. for each 15 degree F increment above or below 70° F . This is not the air temperature but the temperature of the steel or concrete girder as measured by a surface thermometer.

For instance, in our example, the distances between the beam bearing centerlines were taken at 55° F. To compute these distances at 70° F or 15 degrees F warmer, we add 1/8 inch to each measurement:

1/8 inch = 0.0104' rounded to 0.01'

89.99'	59.98'	100.02'	74.99'
<u>+0.01'</u>	<u>+0.01'</u>	<u>+0.01'</u>	<u>+0.01'</u>
90.00'	59.99'	100.03'	75.00'

Notice that we used 0.01 ft. for each span, even though the span lengths varied. This is because we are using a "rule of thumb" and it would be difficult to work with a greater degree of accuracy at this point.

- 2) Compare the distances between the beam bearing centerlines at 70° F to the actual as-built distances between pier pedestal centerlines measured in the field. To do this, you begin at the fixed bearing pedestal, P1, and work toward the expansion bearings (A1, P2, P3, A2) - adding the differences as you progress. For example:

Start at the fixed bearing and work toward the expansion bearings and remember that a positive value for the difference means that a beam bearing centerline is up station from a pedestal centerline of bearing. A negative value difference is down station.

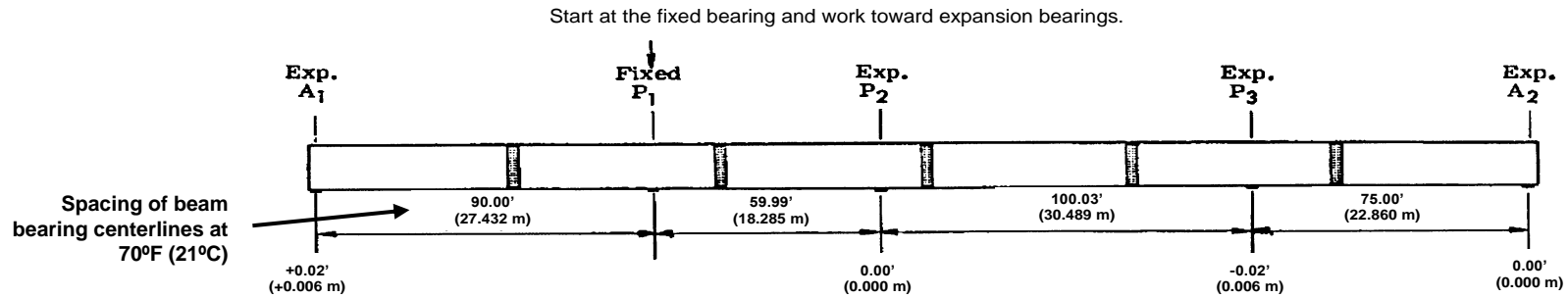

Actual Pier Measurement	90.02'	59.99'	100.01'	75.02'
- Beam Bearing Spacing(70°)	<u>90.00'</u>	<u>59.99'</u>	<u>100.03'</u>	<u>75.00'</u>
Difference	+ 0.02'	0.00'	- 0.02'	+ 0.02'
Cumulative difference	+0.02'	0.00'	- 0.02'	0.00'

Work in two directions. Cumulate the differences in the directions of the expansion.

Here's what the diagram on the previous page means:

- Beams should be set at the fixed bearing first so an adjustment for temperature should never be needed; however, an adjustment for an out of tolerance cap location may be needed. For this example, the fixed bearing is set first so the centerline of bearing for the beam aligns exactly with the centerline of bearing for the pedestal or base plate.
  - The beam bearing centerline at Abutment #1 will be up station by 0.02 ft. from the abutment pedestal bearing centerline.
  - The beam bearing centerline at Pier #2 aligns exactly with the pier #2 pedestal centerline of bearing.
  - The beam bearing centerline at Pier #3 is down station by 0.02 ft from the pier #3 pedestal centerline of bearing.
  - The beam bearing centerline at Abutment #2 will align exactly with the Abutment #2 pedestal centerline of bearing, because the spacing difference between P3 and A2, which is +0.02 ft. , cancels out the difference between P2 and P3 which is -0.02 ft.
- 3) Now we must be sure that proper corrections are made. For all but neoprene bearings, the base plate, also called the masonry plate, has slotted holes that will allow the plate to be shifted as much as one inch. This is usually enough to get exact alignment of the beam bearing centerline and the centerline of the base plate. If the slotted holes do not allow enough adjustment, then the anchor bolts have to be repositioned.

## Q U I Z

- 1) In order to correct differences between fabricated beam bearing centerlines and actual as-built pier, bent and abutment pedestal locations, you must follow three steps. The last step is to be sure that corrections are made. What are the first two steps?
1. \_\_\_\_\_
  2. \_\_\_\_\_
- 2) True or false: bearing alignment corrections of less than 1 inch can easily be made because of the slotted holes in base plates.
- 3) How should you check bearing centerline spacing of beams delivered to the project site? \_\_\_\_\_
- 4) The bearing centerline spacing on a girder is 80.91ft., at 84° F, but the actual field measurement between the bearing centerlines of the pedestals is 81.00 ft.. If the anchor bolts have not been installed, which of the following courses of action probably should be taken?
- A. Erect girder, no corrections needed.
  - B. Adjust bearing centerlines on the pedestals by drilling anchor bolt holes so that the base plate centerlines will match the girder bearing centerlines.
  - C. Move the centerline of bearing plates on steel girders by rewelding.
  - D. Shift base plates on the pedestals to match the girder centerline of bearing by using slotted holes.
- 5) If the anchor bolts had been set already in the problem above, which course of action would probably be taken? \_\_\_\_\_

## **ANSWERS TO QUESTIONS**

### Page 1-6, Locating Bearings

- 1) pedestals, beam seats
- 2) false
- 3) It must be scribed

### Page 1-10, Anchor Bolts

- 1) In the plans and shop drawings
- 2) drilling, grouting
- 3) template

### Page 1-14, Bearing Types

- 1) non-composite bearings, composite neoprene bearing pads, multirotational bearings
- 2) neoprene, steel
- 3) false: fixed bearings do not allow the girder to expand or contract

### Page 1-19, Setting Bearings

- 1) 1. Determine bearing plate spacing at 70° F  
2. Compare spacing at 70° F to pier, bent or abutment pedestal centerline spacing, by calculating the differences in the spacing.
- 2) true
- 3) Measure spacing and match to shop drawings.
- 4) B
- 5) D