

CHAPTER FOUR

DECK CONSTRUCTION

CONTENTS

<i>INTRODUCTION</i>	4-3
<i>PREPARATION</i>	4-3
Pre-operations meeting	4-3
Camber of Girders	4-4
<i>FORMING</i>	4-7
Expansion Joints	4-6
Form Placement	4-9
<i>REBAR PLACEMENT</i>	4-12
<i>SCREED PREPARATION</i>	4-14
Setting the Screed Rail Elevations	4-17

(Contents continued on next page)

CONCRETE PLACEMENT AND SCREEDING	4-19
Placing concrete	4-21
Consolidation	4-23
Screeding	4-23
Checking tattletales	4-26
FINISHING	4-30
CURING	4-32
Form removal	4-33
SMOOTHNESS EVALUATION	4-34
Short bridges	4-34
Long bridges	4-35
GROOVING	4-37
ANSWERS TO QUESTIONS	4-39

INTRODUCTION

The Contractor will place the bridge deck after the beams/girders have been erected. The deck construction work has a number of phases and in this chapter we will cover all phases of deck construction from preparation to curing. Other chapters will cover construction of barrier walls and painting. Your involvement in the construction of decks is especially important since decks require more complex and time dependent processes than other concrete placements. The equipment, such as screeds and pumps, is more complicated which increases the possibility for breakdowns and delays. Requirements for concrete placement, finishing and curing are also more stringent and temperature and weather conditions are far more critical.

PREPARATION

PRE-OPERATIONS MEETING

Before the deck construction operation begins a pre-operations meeting must be conducted to discuss all aspects of the upcoming work. There can be one meeting at which all phases of deck construction are discussed or there can be several meetings that take place just before each phase is due to begin. The meetings should be conducted by the Project Administrator and should be attended by the Contractor's Project Manager, Superintendent, work crew chief or foreman, work crew members if possible and the Department's Senior Inspector and inspectors assigned to the operation. At the meeting, the Department's guidelist for bridge decks or other detailed guidelist should be given to the contractor and all guidelist items should be discussed. Summary minutes should be kept of the meeting and should cover, at a minimum, contingency plans, interpretations of contract documents and unresolved questions that require followup. The following topics should always be discussed at the pre-operations meeting:

- If applicable, changes to the original Concrete Quality Control Plan that are unique to the deck construction operation and a review of the plan with regard to concrete transport and delivery and who will be responsible for coordination of these issues by the Contractor during construction.

- Review of the approved forming system plan.
- Locations for concrete sampling and testing as well as concrete cylinder storage arrangements.
- Review of concrete placement sequence, equipment - such as vibrators - and the number of workers that will be involved in the operation.
- Method of placing, finishing and curing concrete.
- Use of tattletales if required - which will be discussed later in this lesson.
- Other precautions, requirements and “What ifs” or contingency plans. For example: the use of emergency bulkheads; the Contractor's plans for protecting the fresh concrete from the rain; the various curing requirements and time limits in the different parts of the structure; procedures for keeping the concrete within specified temperature ranges; and minimum required concrete placement rates.

CAMBER OF GIRDERS

Both steel and concrete girders are fabricated with an arched shape referred to as “Camber”. All girders bend or deflect downward when dead loads such as a deck are placed on them but when this results in a sag— it is aesthetically undesirable. Camber is used to prevent a beam’s final deflected shape from being a sag. In the illustration on the next page, you can see that the girder that is not cambered sags when the slab is placed but the girder that is cambered bends to a level position under the slab load. In steel girders, the camber is produced by cutting the web plate in the shape of an arch. The designer determines exactly how much camber will be needed to produce a beam that will deflect to the required profile grade without sagging.

In prestressed concrete beams, camber is automatically produced by the prestressing process and can only be estimated by the designer since many variable factors such as humidity and age affect the magnitude of the final camber. In most cases even with all dead loads applied to the girder there is still some camber remaining. As a result, the deck slab directly over the beam flange is usually the minimum required thickness at the center of the span and then gets thicker the closer it gets to the supports. These thicker slab sections over the beams are referred to as “Buildups”. The Contractor is required to monitor the amount of camber for each beam from the

time it is fabricated to the time it is shipped to the project. If the camber is larger or smaller than a predetermined amount, the Contractor must compensate for this by adjusting the profile grade of the deck or by adjusting the elevation of the substructure if it has not been completed. You will need to verify that the Contractor is monitoring camber and if adjustments are needed, that they are carried out properly.

A LEVEL GIRDER - WHEN PLACED ON SUPPORTS AND LOADED - WILL SAG

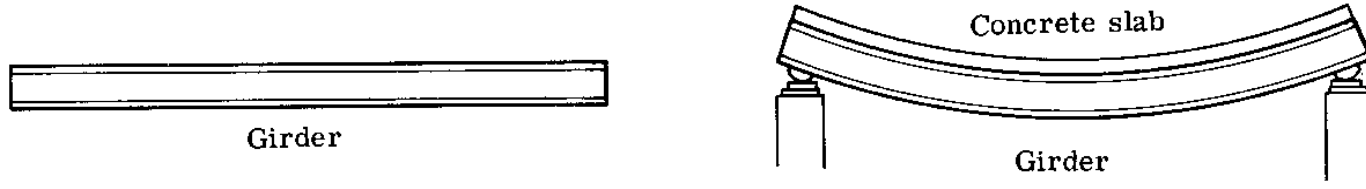

A GIRDER THAT IS CAMBERED - WHEN PLACED ON SUPPORTS AND LOADED - WILL REST IN A LEVEL POSITION

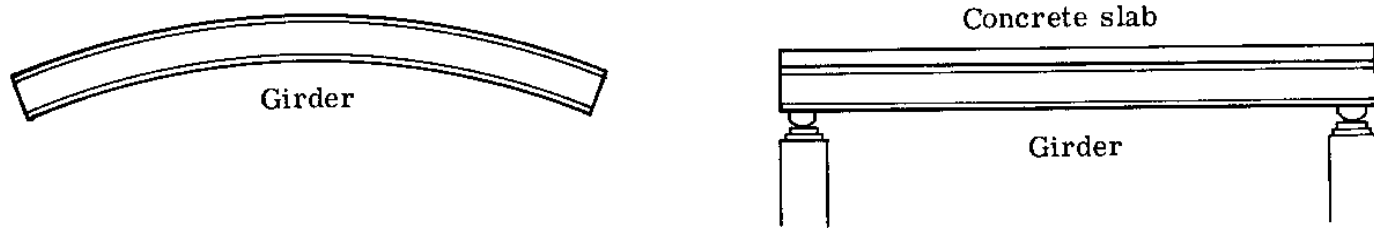



Pictured to the left, is a girder prior to deck casting – notice the slight upward curvature or camber of the girder

Pictured to the right, is a similar girder to the one above after deck casting – notice the relatively flat profile of the girder that has resulted because of the downward deflection caused by the deck load thus reducing the camber



Q U I Z

- 1) True or false: the pre-operations meeting should be attended only by the Project Administrator and the Contractor's Superintendent.
- 2) At the pre-operations meeting, the Department's _____ for bridge decks should be given to the contractor.
- 3) Should the Contractor's contingency plans be discussed at the pre-operations meeting?
- 4) Both steel and concrete girders are fabricated with an arched shape referred to as _____.
- 5) In steel girders the camber is developed by cutting the _____ in the shape of an arch.
- 6) True or false: the designer can determine the exact amount of camber in prestressed girders.

FORMING

[SS 400]

EXPANSION JOINTS

Expansion joint hardware is placed during the form setting process for short bridges and either during form setting or after acceptance of the deck surface for long bridges. Openings between superstructure spans or open joints are used in order to allow the superstructure to expand and contract without damage. When the superstructure expands the open joint is wide enough to prevent the faces of adjacent beams and decks from coming into contact thus preventing damage. However, the open joint allows undesirable drainage water to leak through the deck and when the openings are very wide, vehicle safety and ride quality become unacceptable. These problems are prevented by installing expansion joint seals, which prevent drainage water from leaking through the deck and, for wide joints, provide for the safe and smooth passage of vehicles across the joint.

In general, expansion joint seals will be installed according to the plans and specifications. You should consult the contract plans for the installation requirements, but also be sure that such things as temperature and construction sequence are considered for installation. Expansion joint hardware is placed with temporarily tack welds or bolts that prevent the joint from moving vertically. This assures that proper vertical alignment is maintained across the joint opening until adjacent decks are satisfactorily cured and are up to full strength. The joint opening is referenced to 70 degrees F in order to ensure the proper opening width will be provided.

One more point: you must be sure that metal joint hardware or armor is set properly. This will ensure that the exposed lines of the joint are straight. You must also make sure that the Contractor installs the joint according to the manufacturer's instructions and that all the joint materials comply with the specifications. Typical examples of some common joints are pictured below.

Pictured to the right is a poured Joint with backer rod

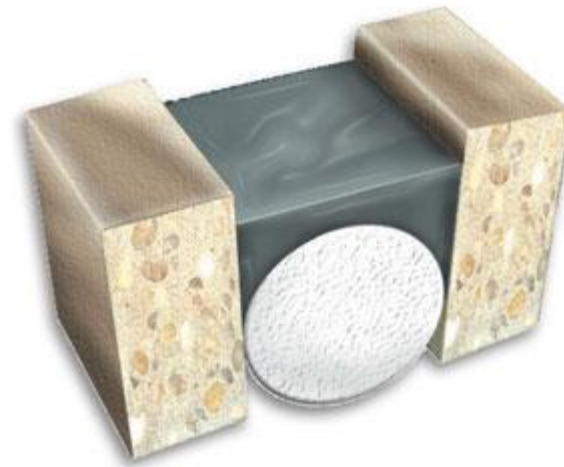



Modular Joint



Finger Joint

FORM PLACEMENT

Forming system plan

The Contractor must submit a forming system plan to the Department for review and approval if the Contractor uses Stay-In-Place (SIP) forms, or for review only, if removable forms. The plan will contain drawings and material specifications for the forms that the Contractor intends to use. You will need to review the plan once it is approved (SIP forms) or reviewed (removable) to be sure that the Contractor adheres to the submitted plan. Pay particular attention to the connection details for connecting the form panels to the beam hardware in the case of SIP forms, and stringer hanger details for removable forms.

With both SIP and removable forms, you will need to monitor that elevations of form panels are correct. Pay particular attention to the thickness of buildups. If buildup depths are too thick - the distance from the top of the

girder flange to the top of the form panel - this could indicate that there is an error in locating the finished grade elevation or that girder cambers are too large. If the top of the form panel is below the top of the girder flange, which means that the flange will penetrate into the deck slab, this is a serious problem. For both situations, the Project Administrator should be consulted immediately. You must also monitor the stability of the forms once in place. They should be stable and firm when walked on since they will be supporting hundreds of pounds of wet concrete. If there is any significant instability, consult the Project Administrator immediately.

In addition to your observation of the buildups, the Project Administrator or Senior Inspector will usually do a rough check of the contractor's form elevations from time to time during the form setting operation.

Removable Forms

Removable forming systems can either be wood, metal or a combination of both. Since removable forms are used over and over again, they wear out and are damaged. You must monitor the condition of the form materials and request the Contractor that damaged or worn out panels and other components be replaced. Also make sure that the form materials comply with the forming system plan and the specifications for form materials quality. Metal hanger hardware that will be left in the slab after form removal must be located so that it can be cut back at least one inch to prevent corrosion after patching. Finally, carefully monitor any welding operations - hanger straps often require welding - that take place on adjoining steel girder surfaces. The significance of this issue is explained more fully in the next section.

Stay-In-Place Forms

SIP forming systems are almost always made of heavy gage galvanized steel sheet metal. It is very important that the Contractor conform to the approved forming system plan since this system will become a permanent part of the finished bridge. The Project Administrator must approve any deviation from the plan. As with removable forms, the quality of the forming materials must meet the specifications. You must make sure that welding operations, which may deposit weld spatter and have other damaging effects on girder steel, associated with SIP form installation, do not come in contact with the permanent steel girder. These operations must be separated from the girder steel by heat proof materials. If this is not possible, then the welding must not take place in the vicinity of the girder steel. This is a very important issue since serious damage to the girder can occur if welding operations are done carelessly, so contact the Project Administrator immediately if the Contractor violates the welding procedures.

When the deck concrete has fully hardened, the Contractor must sound the bottom surface of the SIP forms with a hammer or other appropriate device to check for the existence of flaws. If the deck concrete has flaws or voids the sound the hammer makes when the panel is struck will be different than will solid areas. You must be present during this process. If flaws are found, the SIP form material must be removed in order to determine the extent of the flaws and method of correction.

Q U I Z

- 1) Openings between superstructure spans or open joints are used in order to allow the superstructure to _____ and _____ without damage.
- 2) What is the function of expansion joint seals?
- 3) What must the Contractor submit to the Department for approval before forming begins?
- 4) A buildup that is too thick could indicate that girder camber is too _____.
- 5) True or false: for removable forms, a small amount of form instability is OK since forms do not become part of the permanent deck.
- 6) Are wooden forms tough enough to withstand repeated use without wearing out before the job is over?
- 7) _____ hardware that will be left in the slab after form removal, must be located so that it can be cut back at least one inch to prevent corrosion after patching.
- 8) True or false: welding spatter associated with SIP form straps can come in contact with girder steel without harm.
- 9) What must be done if sounding of SIP forms reveals flaws?

REBAR PLACEMENT

[SS 415]

As with any concrete member, the placement of rebars is critical. The issues you will be concerned about include size, length, spacing, support, ties, grade and quantity. You must verify the following:

- Rebars must be stored properly until placed and be free of foreign matter. A light coating of corrosion is acceptable but a heavier coating must be cleaned off and if advanced corrosion exists the bar must be replaced. Hot bending, welding or flame cutting of rebars is not allowed.
- Rebar mats must be tied with a double strand single tie used at every intersection on the periphery, and for non-periphery locations, every third intersection.
- Mortar block and bolster materials and placement must meet numerous specification requirements, with which you must be completely familiar. For top rebar mats, two rows of continuous high chairs shall be used between beams and shall be spaced 6" from the coping. If individual high chairs are used, they shall be spaced as are continuous ones, but longitudinal spacing shall not exceed 4'. For bottom rebar mats, when bolsters are used, at least two rows must be placed between beams and the spacing between rows must not exceed 4'. One bolster row shall be placed 6" from the coping.
- Metal rebar supports in contact with SIP forms, or that bear on removable forms, must be protected from corrosion by a plastic coating that extends up support legs at least ½" from the point of contact with the form. Supports made of non-corrosive material may also be used and are required for substructures in extremely aggressive environments, and must be in conformance with material requirements in the specification.



This pre-tied rebar cage is being stored until ready for installation. Notice that it is supported off the ground and has been protected from the weather.

Q U I Z

- 1) The periphery of rebar mats must be tied with a _____ tie.
- 2) Are the legs of metal bar supports required to be protected from corrosion?

SCREED PREPARATION

With rare exception, the Contractor will use a screeding machine with the following characteristics (see illustration below):

- It will ride on tracks, called rails, which are set on top of or outside of the deck side forms and that can be adjusted vertically by using a threaded rod or adjusting screw that can be rotated to change the rail height.
- It can be adjusted for different crowns and elevations.
- It has guide tracks from which the strike-off device is suspended.
- The strike-off device (see illustration on next page) consists of two steel drums that rotate and which do the actual strike-off and smoothing of the concrete; an auger that pushes excess concrete ahead of the drums; vibrating drums (Rollatamp) with fins on the surface that push the large aggregate down into the concrete which causes the cement paste to rise to the surface (these drums are optional and are not always used); and a drag, which is usually a burlap covered metal pan that adds smoothness and texture to the surface of the screeded concrete.

TYPICAL SCREEDING MACHINE

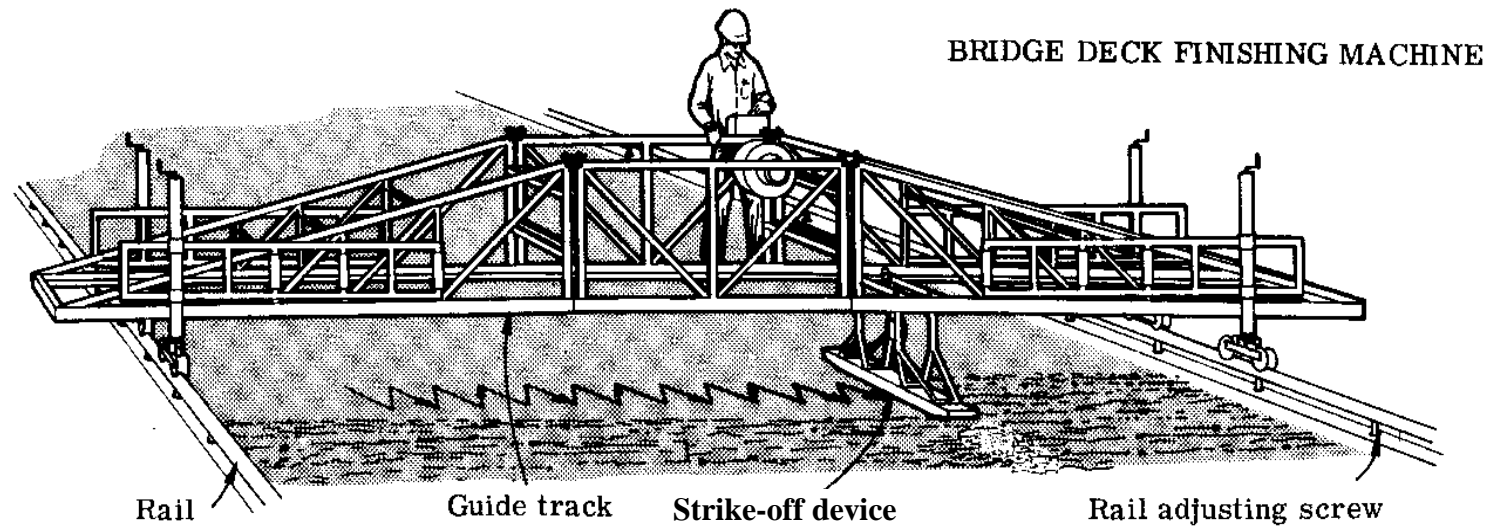

TYPICAL DUAL DRUM ROLLER STRIKE-OFF DEVICE

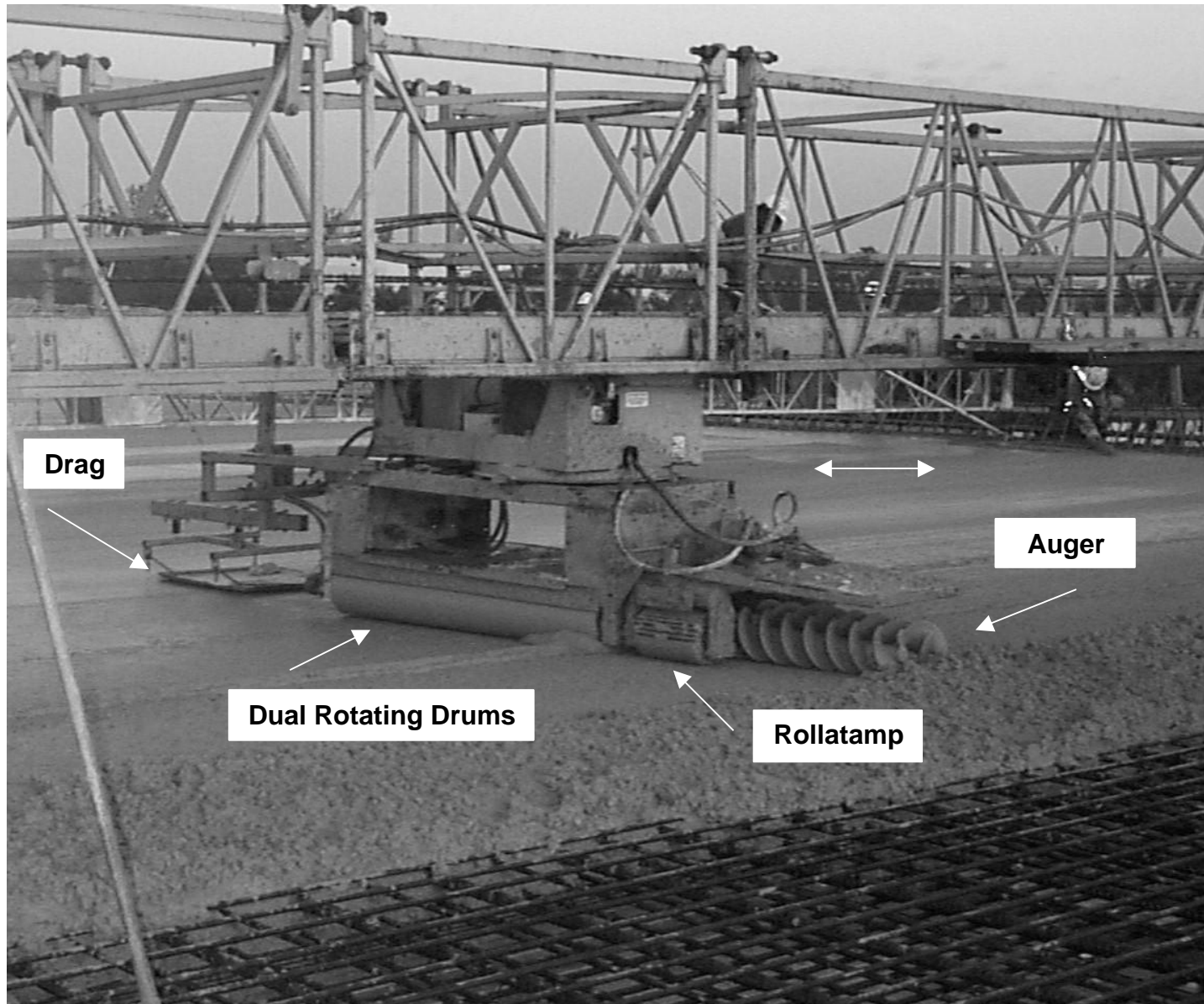

Contractors also occasionally use simple straight edge type screeds which consist of a straight screed bar suspended from a light truss that is pulled forward through the concrete and which vibrates. These type screeds are used for small or irregular placements. While handheld or backpack vibrators may be used to consolidate deck concrete, specifications require that all deck screeds be equipped with internal vibrators as well.

SETTING THE SCREED RAIL ELEVATIONS

While the rebars are being placed, the Contractor will begin placing and adjusting the rails on which the screeding machine will ride. Once all rebars have been placed and checked, the screed will be positioned on its rails in preparation for the concrete placement operation. At this point, the Contractor will test the screed in order to make sure that it operates properly and that it will strike-off the concrete so that the required slab thickness will be achieved as well as the minimum concrete cover over the top rebar mat. This process is referred to as a “Dry Run”.

During the dry run you will need to take periodic measurements of the expected slab thickness as well as the cover thickness (see illustration). The measurements should be taken approximately every 10 feet longitudinally and transversely over the forms at each beam flange end and at the slab edges. Attaching a wood plank or steel plate to the bottom of the screed drums that spans across the two drums can do this. This will provide a true and level surface from which to measure. At each check location a ruler, held in a plumb position, can be used to verify that the slab thickness is the minimum thickness, usually 8” or 8.5”, and the concrete cover is the minimum over the top mat, usually 2” or 2.5”. Based on your measurements, the Contractor will adjust the screed rails to provide the required dimensions. If the dimension deviations cannot be adjusted out, you must notify the Project Administrator who will address this issue with the Contractor.

During the dry run process you must verify that both bulkheads at the ends of the slab, match the crowns and top of deck surface profile of the adjacent slabs. Also, the smoothness of the transition from adjacent finished slabs to the slab being placed should be checked by extending half the length of a straight edge from the adjacent slab over the slab to be placed. The screed should be at the end of the span for this check and the drums should have a true alignment with the straight edge to ensure a smooth ride for vehicles.

Finally, be sure the deck finishing machine operates on the bridge centerline without regard for skew, as shown on the next page.

TAKING DRY RUN MEASUREMENTS

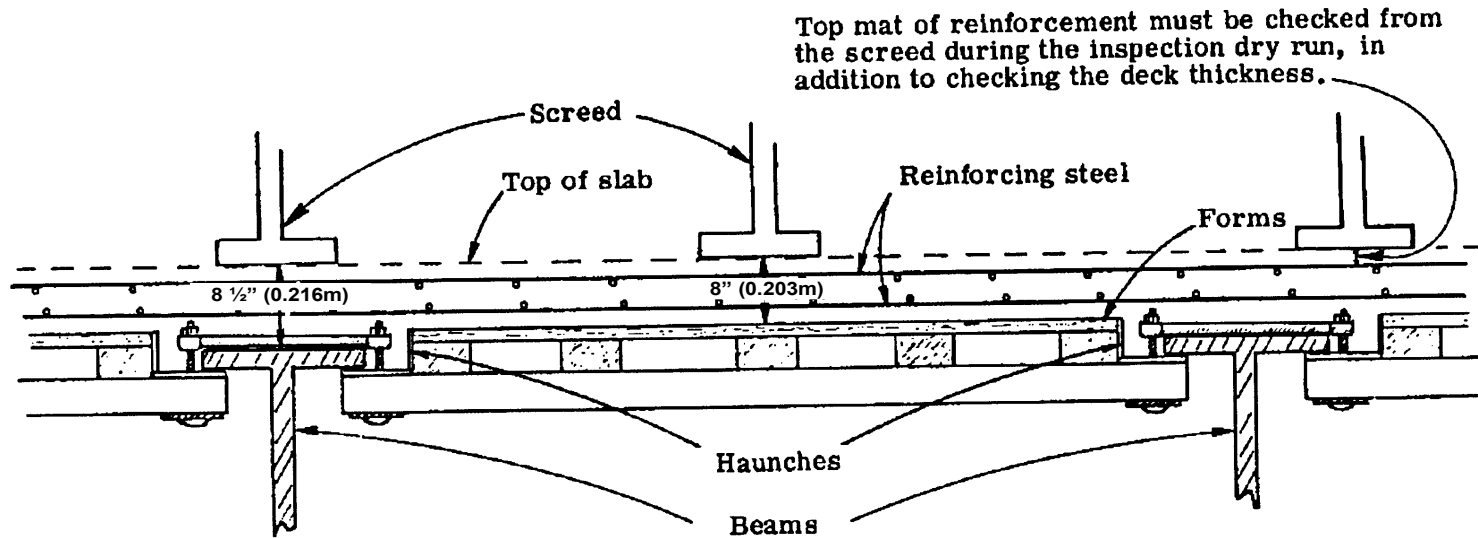

SCREED MUST BE PARALLEL TO BRIDGE CENTERLINE

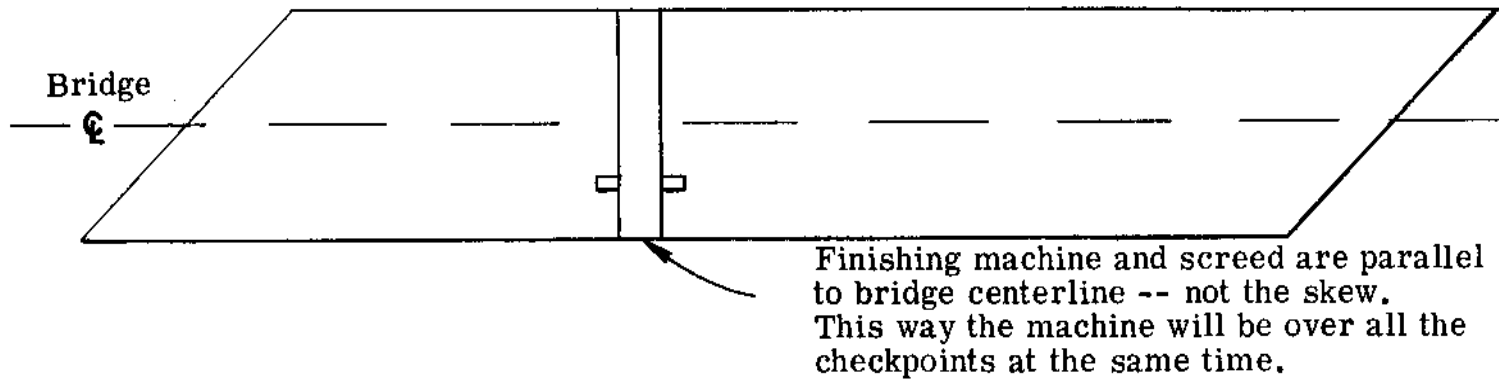

Q U I Z

- 1) Screed rail elevations are adjusted by using what?
- 2) The strike-off device has _____ that strike-off and smooth the concrete.
- 3) Name the two dimensions you will be measuring during the dry run.
- 4) True or false: it is not critical that the crown of the adjacent finished slab match the slab being placed.
- 5) Should the direction of screed advancement be parallel to the bridge centerline?

CONCRETE PLACEMENT AND SCREEDING

[SS 400]

Once the rebars are placed and the screed is checked out to make sure proper cover and slab thickness will be achieved, it is time to place the concrete. As mentioned previously, deck concrete placement is complex and time dependent. Because of the relatively small thickness of the slab and large exposed surface area, the concrete sets up quickly and is very susceptible to accelerated drying due to wind, low humidity and high heat which are often the conditions during deck placements in Florida. This makes it very important for the concrete to be placed as quickly as possible and the specification requires a minimum production rate of 20 cubic yards/hour for placements of 50 cubic yard or less and 30 cubic yards/hour for placements of more than 50 cubic yards.

You must monitor the placement rate and the weather conditions. If the weather is excessively windy, dry, or hot, or it is very likely to rain, you should notify the Project Administrator who may suggest to the Contractor that the placement be delayed until weather conditions are more favorable. Also, you should make sure that the Contractor has a rain protection system immediately available, that has been demonstrated to be effective and

that can be installed quickly. The Contractor must also estimate the rate that moisture evaporates off the surface of the deck (evaporation rate) during concrete placement by using temperature, humidity and wind speed instruments on site and/or by checking with the local weather bureau. If the estimated evaporation rate during the concrete placement will exceed 0.2 lb/ft²/hr then evaporation countermeasures must be used or the placement must be postponed until more favorable weather conditions exist. Countermeasures could include the use of a chemical evaporation retarder, continuous water fogging or the installation of wind screens. The evaporation rate is computed by using a special nomograph that you must know how to read and which will be provided by the Project Administrator so that you can verify the Contractor's evaporation rate estimate.

Another very important issue that must be verified is the concrete placement sequence. For simple spans, the entire deck is usually placed in one continuous operation; however, occasionally only part of the deck is placed. You must review the plans, which will indicate in what order each part of the deck must be placed. For continuous spans - no expansion joint between spans - the concrete placements must be in sections and cannot be placed in one continuous operation. Again, the plans will have the order of concrete placements and this order must be followed precisely or serious damage can occur to the new deck slab. If the order is incorrect, a newly placed deck section could be subjected to high tension stresses before it has developed adequate strength, which will cause severe cracking. Concrete must not be placed until the Project Administrator has approved the concrete placement sequence. For simple span beams with continuous decks, a best practice is to always start the concrete placement at the end opposite an existing completed deck slab thus ending the concrete placement at a cold joint with the hardened concrete. This procedure reduces the possibility of deck cracks that form during or immediately after concrete placement.

PLACING CONCRETE

Just prior to the start of concrete placement, the forms must be sprayed with cool fresh water. This prevents wooden forms from drawing excessive amounts of water out of the concrete, which is undesirable, and also helps prevent the concrete from sticking to the forms.

There are several approved methods for moving concrete from the concrete delivery vehicle - which can be a concrete truck, barge hopper, etc. - to the point of placement in the forms. Two of these methods are the most commonly used: 1) crane and bucket, or 2) concrete pump.

For the crane and bucket method, concrete is discharged from the delivery vehicle into a large bucket that is suspended from a crane and that has a door that can be opened by the worker to allow discharge. The crane will swing the bucket into position over the area where the concrete is deposited. This cycle is repeated numerous times until the delivery vehicle is empty.

The Contractor's workmen at the point of placement will release the concrete by opening the door of the bucket as the crane suspends the bucket above the deck. This operation is critical, since the concrete must be deposited as close as possible to its final resting place. In tight areas such as corners, the workmen may need to hand shovel the concrete. In general, precise placement is difficult with a bucket and; therefore, concrete is often placed in mounds that must be leveled out before the screed passes. You should try to encourage the workers to avoid mounds and instead attempt to distribute the concrete more uniformly over the surface of the forms. Also, the concrete must not be dropped more than 5' from the bucket or pump discharge end.

For the concrete pump method, the delivery vehicle discharges into a pump truck which pumps the concrete through a hose directly to the point of placement. The discharge hose is almost always suspended above the placement area and this allows the worker to easily move it to any location over the forms. As a result, placement is more uniform and can be done more quickly because the pump discharges continuously until the delivery vehicle is empty. In recent years concrete pumps have become more popular and are usually used on large projects.



Concrete Placement Bucket



Deck Placement Using a Concrete Pump

Regardless of placement method, the concrete delivered to the deck must be uniform in composition, workability and consistency. Wet or dry loads should not be placed, since they may cause unevenness in portions of the surface after it has been struck off. The concrete should be leveled by workers to a degree that the screed will have only a small amount of concrete to push out of the way as the strike-off proceeds. The specifications require that external hand held vibrators be used to consolidate the concrete around the reinforcing steel and in the corners of the forms.

CONSOLIDATION

As soon as the concrete is placed, it should be consolidated with portable hand held vibrators having an approved size and frequency. Due to the large number of rebar used in deck construction, vibrators must be used at close intervals. Keep your eye on this operation to be sure that the workmen do not use the vibrators to spread concrete into corners or low spots. As you previously learned, spreading concrete with vibrators will result in segregation. Immediately around the vibrator head, the surface of the concrete will display the effects of the vibrator with a wavy appearance and this is referred to as the circle of vibrator influence. The vibrator should be placed in the concrete often enough so that the circles of influence overlap, which will assure that the entire volume of concrete is fully consolidated. Also, the vibrator head should be kept as vertical as possible the entire time it is in the concrete and should penetrate down to the bottom of the slab.

SCREEDING

After placement and consolidation of the concrete is underway for a short time, the screed begins to operate. The screeding machine strikes off and smoothes the concrete surface as it moves back and forth across the deck and it ensures that the top of the slab is at the correct elevation or grade.

Screeding also helps to consolidate the surface. The trailing ends of the rotating drums are usually set about 1/8-inch higher than the leading end so that ridges in the concrete surface will not be left by the screed. To get the best job of strike-off, the concrete layer just in front of the screed must be higher than the final slab surface will be, by a small amount - in the 2" range. Be sure that the workmen maintain this layer in the correct thickness range. If they do not, a low spot can get filled with cement paste only, which is not as strong or as durable as the concrete; or a layer that is too thick will lift the screed machine, creating high spots.

During deck placing operations, you should be sure that the screed is operated in the following manner:

- The overlapping of screed passes should be governed by the workability of the concrete and the closing or smoothing of the concrete surface behind the finishing machine. Each pass of the drums should overlap the previous pass so that they can cut off any excess that might have rolled under on the previous pass. Usually the screed is advanced 3 to 6 inches but not more than 12 inches into the new

concrete during each pass.

- Excess concrete at the gutter line must be removed and disposed of properly.
- Sometimes screed rail supports will bear on a beam. In this case, immediately after screeding is completed, the screed rails and their supports must be removed without disturbing the screeded concrete. Holes left after support removal must be filled with fresh concrete, not with mortar or concrete screeded off the surface.
- The rate of placement is critical. If operations slow down, you must be sure that the Contractor is trying to correct the situation. If the situation is not corrected, you should consult with the Project Administrator.

Check the slab for minimum thickness and for minimum rebar cover after it has been screeded and while the concrete is still fluid. The concrete must be checked at random locations with a marked probe approximately every 500 square feet of deck. The results must be kept in a permanent field book and the detailed requirements for recording the data are specified in Section 10.3 of the Department's Construction Project Administration Manual. It is important that you follow the instructions for recording this data very carefully.

The best way to locate the places you want to check on the bridge is to:

- Mark the screed machine's bridge with keel (chalk) at the places where the thickness checks were made. This will allow you to measure how far the check point is from the edge of the bridge.
- Tie ribbon to the barrier steel at places along the deck where checks were made. This will help determine the survey station of the check point.
- The rebar cover check can be checked at the same location as the slab depth. This is done best with a thin metal plate at least 4" high and 8" long attached to a rod. When the long edge of the plate is pushed into the plastic concrete it will come to rest on the top mat of rebar. If the plate is marked at 1/4" intervals, the thickness of the cover concrete can easily be determined. More sophisticated devices are also available for this type of measuring, so consult your Project Administrator for more information.



Homemade Rebar Cover and Slab Depth Check Gauge

CHECKING TATTLETALES

During the placement of concrete, you must check the tattletales for deflection if the Project Administrator requires their use. Tattletales are attached to the beams and deck finishing machine rails to register the amounts of deflection during concrete placement. As the first 10 ft. of deck concrete is placed, you should check the tattletales below the deck. If they are dropping more than anticipated, then you should contact the Project Administrator and Contractor and be sure that corrections are made in the lengths of the rail adjusting screws. The diagram below shows how the tattletales are used.

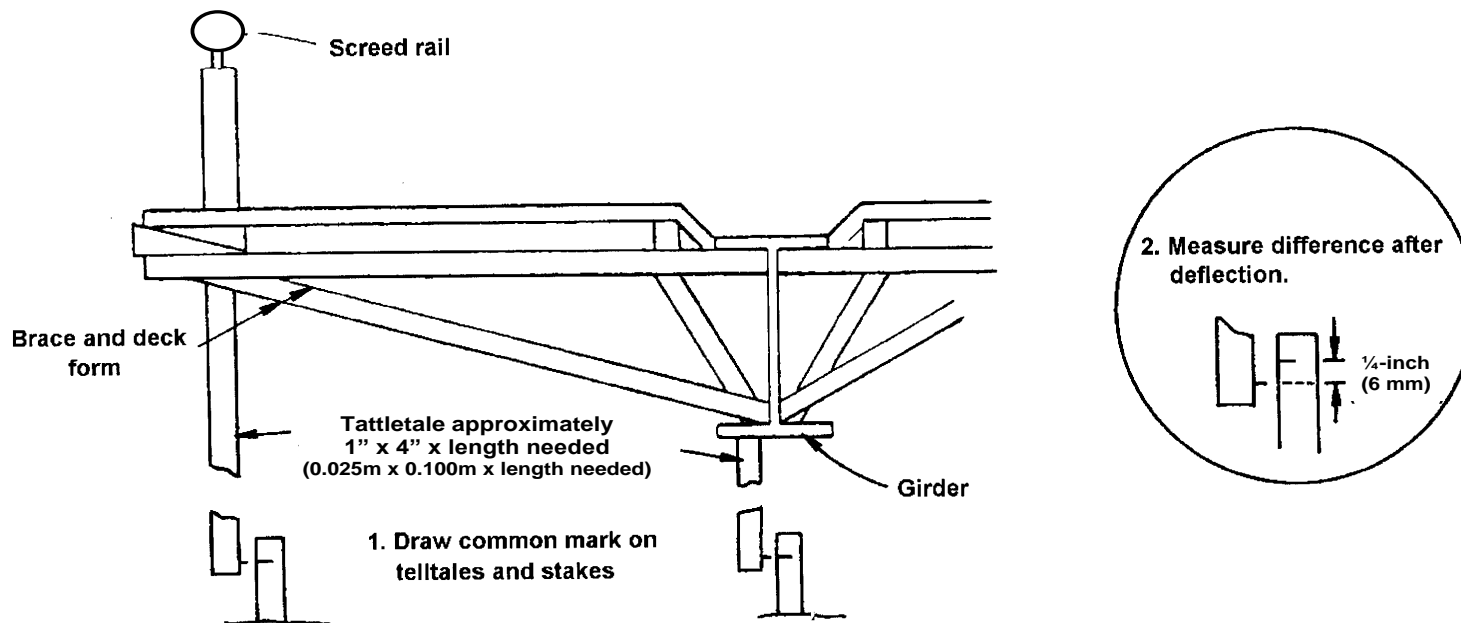

A method of documenting tattletale results is shown below.

Note

Dry Run High Rail set 0.02' (6.10 mm) above finish grade
Dry Run Low Rail set 0.03' (9.14 mm) above finish grade

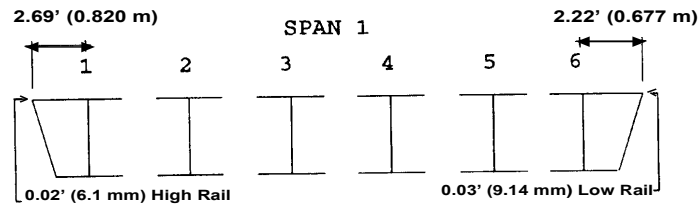

	Rail	1	2	3	4	5	6	Rail
Weight of Machine and concrete	0.02 (6.10)	0.01 (3.04)	0.01 (3.04)	0.00 (0.000)	0.01 (3.04)	0.005 (1.52)	0.01 (3.04)	0.005 (1.52)
Weight of machine and concrete at pier	0.03 (9.14)	0.015 (4.51)	0.02 (6.10)	0.05 (15.24)	0.02 (6.10)	0.01 (3.04)	0.01 (3.04)	0.01 (3.04)
Final Deflection at Bulkhead	0.01 (3.04)	0.005 (1.52)	0.01 (3.04)	0.00 (0.000)	0.01 (3.04)	0.00 (0.000)	0.01 (3.04)	0.00 (0.000)
Deflection units in feet and (mm)								

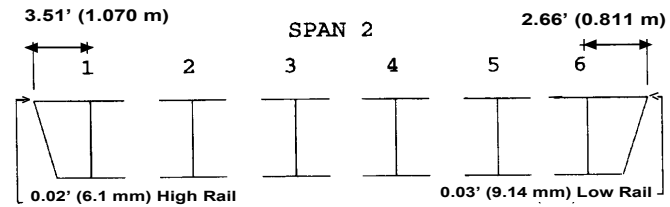

	Rail	1	2	3	4	5	6	Rail
Weight of Machine and concrete	0.07 (21.34)	0.06 (18.29)	0.07 (21.34)	0.07 (21.34)	0.07 (21.34)	0.075 (22.86)	0.08 (24.38)	0.09 (27.43)
Weight of machine and concrete at pier	0.08 (24.38)	0.065 (19.81)	0.075 (22.86)	0.08 (24.38)	0.075 (22.86)	0.05 (15.24)	0.085 (25.91)	0.09 (27.43)
Final Deflection at Bulkhead	0.05 (15.24)	0.05 (15.24)	0.05 (15.24)	0.05 (15.24)	0.04 (12.19)	0.04 (12.19)	0.04 (12.19)	0.04 (12.19)
Deflection units in feet and (mm)								

Note that tattletale results for each span are recorded three times:

1. when the weight of the machine and concrete are over the tattletaes
2. when the weight of the machine and concrete are over the pier
3. when the weight of the machine and concrete are over the bulkhead

These results will be useful in the future, but are not used to correct the deck being placed.

Q U I Z

- 1) What is the minimum production rate for deck concrete placements of more than 50 cubic yards?
- 2) True or false: the likelihood of deck cracking is greatly affected by weather conditions.
- 3) For continuous spans, the concrete placements must be in _____ and cannot be placed in one continuous operation.
- 4) The two most common concrete placement methods are?
- 5) Spreading concrete with vibrators will result in _____.
- 6) Name two things that are wrong with the consolidation shown below:

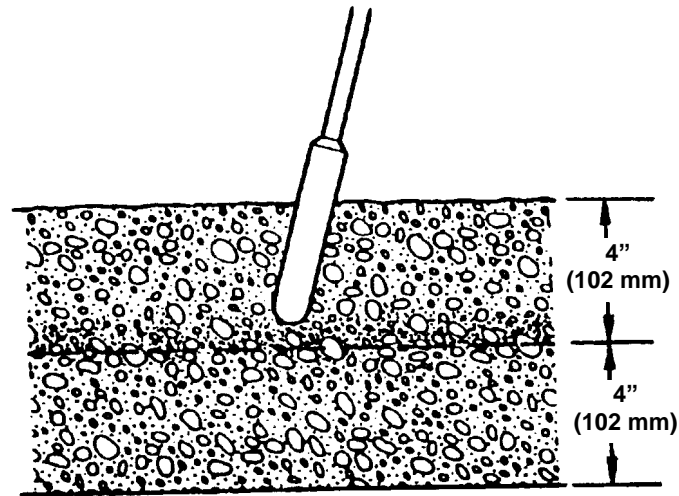

QUIZ, continued

- 7) What should be done to fill a large gap between piles of concrete?
- A. Finish the concrete as is, leaving a small depression.
 - B. Place more concrete in the gap.
 - C. Move concrete from the previously placed piles, to fill the gap.
- 8) Usually the screed is advanced ___ to ___ inches into the new concrete during each pass.
- 9) The concrete must be checked behind the screed at random locations with a marked probe approximately every ___ square feet of deck.
- 10) When should you first check tattletales for deflection? _____
- 11) After this initial check, you should check when concrete is placed over _____, _____ and _____ .
- 12) If the last section of a deck is being placed, but the tattletales show that the grade is not being reached, how will the concrete and reinforcing steel be affected? _____

FINISHING

[SS 400]

The quality of the bridge deck finish is important because it affects the skid resistance as well as the smoothness and uniformity of the ride for motorists.

The first opportunity the Contractor will have to check the flatness of the deck for short bridges is right after completing consolidation, strike-off, and screeding of the concrete, but while it is still plastic. This requires the Contractor to furnish and employ an accurate straightedge having a minimum length of 10 ft. You should verify that the straightedge is true before the Contractor uses it.

The 10 ft. straightedge should be placed on the deck surface for short bridges at 5 ft. intervals, also called half-lapping, and must be aligned and advanced in the direction of traffic. The entire deck must be checked, so the straightedge should be advanced across the deck as well, at approximately 5 ft. intervals. A surface depression with a gap beneath the straightedge of deeper than 1/8 inch. should be immediately filled with freshly mixed concrete, struck off, consolidated and refloat. Areas greater than 1/8 inch must be lowered and refloat. The straightedge checking and refloating should continue until the entire deck surface is found to be free of deviations from the straightedge and has the required grade and contour. Your role during this process is to check that straightedge intervals are followed and deviations are corrected properly.

After the high and low areas of the deck are corrected, the surface must be finished to a uniform texture by the use of a burlap drag, fine bristle broom or float. The surface should not have flaws greater than 1/16 inch deep after the texture is applied.

For long bridges, floating and texturing of the concrete surface behind the screed is prohibited with some exceptions and; therefore, straightedging is not required. This is because a minimum of 1/4" of deck surface is required to be removed by a grinding or planing machine at some time after the concrete is fully cured. The grinding or planing process ensures that the deck will ride smoothly and eliminates the need to have a highly finished surface immediately after concrete placement. This also eliminates the need to add water to the deck to facilitate floating and texturing operations.

Q U I Z

- 1) The Initial straightedge check should be performed while the concrete is still _____.
- 2) The straightedge is half-lapped every _____ feet in the direction of travel.
- 3) True or False: low areas in plastic concrete can fail the straightedge by ½ in. before they must be corrected.
- 4) For short bridges, flaws greater than what depth require correction?

CURING

[SS 400]

Curing of the deck, perhaps more than any other component of the bridge is very critical. This is true because the deck is directly and continuously exposed to the deteriorating effects of vehicular traffic and extreme weather conditions. If deck curing is done poorly, cracks will form early in the life of the deck and these will cause the concrete to wear out far earlier than for a properly cured deck. Sometimes Contractors do not take curing as seriously as they should, and so you must encourage them to be as conscientious as possible about this critical operation.

As soon as the Contractor has completed the deck finishing operation, curing compound must be applied to all exposed surfaces, including surfaces that will be covered by barrier walls. Compound must be applied to the surface as soon as it dries to a damp condition or within 120 minutes whichever comes first. The compound must be applied without delay because during the period following finishing, rapid drying of the concrete is taking place, and this can cause severe cracking. The Contractor must apply Type 2 membrane curing compound at a rate of at least 1 gallon to every 150 square feet and in accordance with Standard Specification 925. The Contractor is required to report to the Project Administrator how the spread rate will be determined prior to application and once compound application is complete for a given deck placement, the quantity used must be reported to the inspector for verification. A rule of thumb for visually determining if the spread rate is adequate is "All White is Right". So if the surface is completely white without the gray deck color showing through then the spread rate is probably adequate but remember the Contractor is still required to report the spread rate for every concrete placement.

Once the deck concrete is hard enough, curing blankets must be placed on all exposed surfaces that are not formed with the exception of the areas beneath future barrier walls. The curing blankets as approved by the Project Administrator must be overlapping sufficiently to form an effective moisture seal. The blankets must be in good condition and you should check to see that blanket materials conform to the detailed requirements in the specification. The blankets must be kept wet immediately after satisfactorily placing them and be maintained in a saturated condition throughout the seven-day curing period. There must be a sufficient quantity of fresh water at the job site for wetting the blankets. You must be very vigilant about checking that wetting is continuously maintained, since Contractors can do a poor job of managing this operation and it is very critical that the blankets stay wet at all times.

Where a bridge deck slab is to be subjected to walking, wheeling, or other approved construction traffic within the

seven day curing period, the blankets and deck must be protected from damage by placing wooden sheeting, plywood or other approved protective material in the traveled areas. When the ends of the curing blankets are rolled back to permit screeding of adjacent bridge deck slabs, the exposed surfaces must be kept wet by spraying water throughout the period of exposure.

As you can see, the deck curing requirements are very detailed and comprehensive and so it is especially important that you make sure the Contractor addresses them properly.

FORM REMOVAL

Generally the forms on the underside of the deck must be kept in place for seven days. The specifications do allow removal of the forms after 72 hours but in order to do so, the Contractor must break cylinders to demonstrate that minimum concrete strengths have been achieved. You must be completely familiar with the detailed specifications for establishing the proper cylinder break procedure, which is governed by temperature and curing conditions and you must witness the cylinder breaks. Regardless of the procedure used, forms must not be removed until authorized by the Project Administrator. If forms are removed prior to the seven-day limit, curing compound must be applied to the exposed slab surfaces within two hours of form removal. The minimum curing compound spread rate is the same as that which is required for the top of deck surface.

Remember that once forms are removed, the Contractor must remove all form system components including embedded metal hardware, which must be cut back at least one inch into the slab. Cut back holes must be patched as well as other minor voids or flaws. Large flaws must be brought to the attention of the Project Administrator so the best method for correction can be determined. As mentioned previously, stay-in-place forms must be sounded for flaws.

Q U I Z

- 1) Proper deck curing is especially important because the deck is directly exposed to _____ and _____.
- 2) True or false: curing compound must not be applied sooner than 2 hours after finishing is complete.
- 3) The minimum application rate for curing compound is 1 gallon to every _____ square feet.
- 4) How many days must curing blankets remain in place before they can be removed?
- 5) What must be continually maintained for the deck not to form cracks?

SMOOTHNESS EVALUATION

[SS 400]

Once the deck is fully cured and hard, surface flaws must be corrected based on whether the bridge is categorized as short or long. A bridge is considered to be "Short" if the combined length of deck and approach slabs is less than or equal to 100 ft. Long bridges have a combined length of greater than 100 ft. It is your job to make sure the Contractor corrects all unacceptable flaws.

SHORT BRIDGES

For short bridges, a final straightedge check must be performed using the same positioning procedure as described previously in the Deck Finishing section. High spots of 3/16 inch or greater must be ground down to 1/8 inch or less. Significant depressions or low spots must be brought to the attention of the Project Administrator who will determine a method of correction. Make sure the grinding operation results in a smooth uniform surface.

LONG BRIDGES

The degree of smoothness must be determined by using a special machine called a Profilograph. This machine is a rolling straightedge that automatically records (electronically and with paper printout) the variations in the surface smoothness through use of a computer. The Prime Contractor must hire a subcontractor approved by the Department to supply and operate the profilograph and to report the results. The subcontractor must be independent, which means there must be no ownership or partnership connection with the Prime Contractor. The profilograph must be calibrated by the Department and you will need to verify that subcontractor and equipment is approved. For a fee and when available, the Contractor may also use the profilograph services of the Department's State Materials Office.



Profilograph Being Used on Concrete Pavement

The profilograph must be operated in all traveled lanes including future lanes. Before the profilograph is used, the bridge deck must be as clean as possible to assure the accuracy of the check and the right and left wheel line of each traveled lane must be checked with the profilograph. Two variances are checked by the profilograph: overall smoothness, which must not exceed 10 inches/mile, and isolated high and low points which must not exceed 0.3 in. per 25 ft. Both variances are displayed on the profilograph printout. The Contractor may also be required by the Project Administrator to perform a manual straightedge check across the deck or in the transverse direction, if the smoothness in this direction looks like it is a problem. If this is required, the variance must not exceed ¼ in. per 10 ft.

The Contractor is required to grind at least ¼" of deck surface off regardless of the initial profilograph results; however, the initial profilograph results are intended to help the subcontractor that performs the grinding to determine the best settings for the grinding machine prior to the start of the grinding operation. After the initial ¼" or more is removed another profilograph pass must be performed. If your review of the profilograph printout shows more than 10 inches/mile for the overall variance, notify the Project Administrator of your findings. After his review of the data, he will probably require the Contractor to regrind or plane the entire deck. Variances of more than 0.3 in. per 25 ft. for isolated high points will only require spot grinding by the Contractor if the overall variance is within tolerance. Isolated low points must be brought to the attention of the Project Administrator who will determine a method of correction. If the overall variance is still out of tolerance after the second pass, planing may be required again and the entire cycle of profilograph and planing must be repeated until the variance is within tolerance. However, the maximum allowable total concrete removal during planing is ½ inch and it is important that you make sure that the Contractor is aware of this. The deck is constructed with an extra ½ inch of cover to compensate for removal by planing so if the removal exceeds this amount, the concrete cover that protects the rebars is reduced.

Q U I Z

- 1) Deck high spots on short bridges must be ground down to no more than what dimension?
- 2) True or false: the inspector must verify that the planing subcontractor and his equipment are approved.
- 3) For long bridges, overall smoothness variance must not exceed _____ and isolated high points must not exceed_____.
- 4) Smoothness variance in the transverse direction must not exceed what dimension per 10 ft.?
- 5) The maximum concrete removal during planing is _____.

GROOVING

[SS 400]

In order to improve the skid resistance and reduce hydroplaning - the tendency of vehicle tires to float on top of the rain water at high speeds - of the deck surface, the Contractor must cut grooves into the surface transverse to the direction of travel. This is only done after the smoothness evaluation is complete and accepted. The grooves are cut by using a mechanical device that will leave grooves nominally 1/8th inch wide and 3/16 inch deep. The groove spacing varies, as covered in the specification, and the sequence repeats every 7 spaces. The specification also establishes tolerances for groove widths, depths and spacing.

The grooves are cut continuously across the deck or approach slab to within 18 inches of gutter lines at the barrier wall, curb line and median divider. The specification has spacing requirements for grooves adjacent to metal expansion joints, armored joints, gutter lines, curb lines and median barriers. You must make sure that the Contractor is familiar with all the spacing and dimension requirements before grooving begins and also verify that actual cutting is done as required.

Q U I Z

- 1) Why are decks grooved?
- 2) True or false: grooves should be nominally $\frac{1}{2}$ in wide.
- 3) Grooves are cut continuously across the deck to within _____ of gutter lines at the barrier wall.

ANSWERS TO QUESTIONS

Page 4-7, Preparation

- 1) False
- 2) guidelist
- 3) Yes
- 4) cambered
- 5) web plate
- 6) False

Page 4-11, Forming

- 1) expand, contract
- 2) prevent drainage water from leaking through the deck and provide for the safe and smooth passage of vehicles across the joint
- 3) forming system plan
- 4) large
- 5) False
- 6) No
- 7) Metal hanger

8) False

- 9) SIP form material must be removed in order to determine the extent of the flaws and method of correction

Page 4-14, Rebar Placement

- 1) 1 inch (25 mm)
- 2) double strand single
- 3) Yes

Page 4-19, Screed Preparation

- 1) adjusting screws
- 2) dual rotating drums
- 3) minimum slab thickness, minimum concrete cover over the top mat of rebars
- 4) False
- 5) Yes

Page 4-28, Concrete Placement and Screeding

- 1) 30 cubic yards/hour (23 cubic meters/hour)
- 2) True

- 3) sections
- 4) crane and bucket, concrete pump
- 5) segregation
- 6) vibrator head is not vertical, vibrator head is not penetrating to the underlying layer
- 7) C
- 8) 3 to 6 inches
- 9) 500 square feet
- 10) After the first 10' of deck concrete has been placed.
- 11) tattletales, piers, bulkheads
- 12) slab thickness and cover will be increased

Page 4-31, Finishing

- 1) Plastic
- 2) 5 feet
- 3) False
- 4) 1/16th inch

Page 4-34, Curing

- 1) vehicular traffic, extreme weather conditions
- 2) False
- 3) 150, 3.75
- 4) 7
- 5) wetting

Page 4-37, Smoothness Evaluation

- 1) 1/8 inch
- 2) True
- 3) 10 inches/mile, 0.3 in. per 25 ft.
- 4) ¼ inch
- 5) ½ inch

Page 4-38, Grooving

- 1) improve skid resistance and reduce hydroplaning
- 2) False
- 3) 18 inches