

---

Structures and Materials Research Report No. 96-3  
FINAL PROJECT REPORT

September 1996

UF Project No. 4910 45 04 498 12  
HPR Study No. 0662  
State Job No. 99700-3507-119  
Contract No. B-9195  
WPI No. 0510662

---

**SPECIFICATIONS  
FOR  
ADHESIVE-BONDED ANCHORS AND DOWELS**

---

Ronald A. Cook  
Robert C. Konz  
Daniel S. Richardson

---

Department of Civil Engineering  
College of Engineering  
UNIVERSITY OF FLORIDA  
Gainesville



Engineering and Industrial Experiment  
Station

---

1. Report No. <b>FL/DOT/RMC/0662-9195</b>		2. Government Accession No.		3. Recipient's Catalog No.	
4. Title and Subtitle <b>Specifications for Adhesive-Bonded Anchors and Dowels</b>				5. Report Date <b>September 1996</b>	
				6. Performing Organization Code	
				8. Performing Organization Report No. <b>4910450449812</b>	
7. Author(s) <b>R.A. Cook, R.C. Konz, D.S. Richardson</b>				10. Work Unit No. (TRAIS)	
9. Performing Organization Name and Address <b>University of Florida Department of Civil Engineering 345 Weil Hall / P.O. Box 116580 Gainesville, FL 32611-6580</b>				11. Contract or Grant No. <b>HPR 0662</b>	
				13. Type of Report and Period Covered <b>Phase II Report 11/30/94 - 9/30/96</b>	
12. Sponsoring Agency Name and Address <b>Florida Department of Transportation Research Management Center 605 Suwannee Street, MS 30 Tallahassee, FL 32301-8064</b>				14. Sponsoring Agency Code <b>99700-3507-119</b>	
				15. Supplementary Notes <b>Prepared in cooperation with the Federal Highway Administration</b>	
16. Abstract <p>The purpose of this research was to develop specifications and a qualification procedure for using adhesive products to bond anchors and dowels to hardened concrete. This method will establish the nominal bond strength of an adhesive product and the relative effects of several influence factors. A total of 1308 tests were performed (in two phases) on 20 commercially-available products and two prototype formulations.</p> <p>The results of the first phase of the test program includes test series for a baseline reference, and various installation and in-service conditions. Testing during the second phase included additional series for installation and in-service conditions, and long-term service conditions.</p> <p>In addition to bond-strength testing, a method of adhesive identification (fingerprint) was developed to establish a unique reference set of chemical and physical properties to verify the composition and proportions of a product. The purpose of this "fingerprint" is to infer performance characteristics of an unknown or future batch of adhesive.</p> <p>Finally, four draft documents were developed to assist the FDOT in implementing a qualification method. Two Standard Specifications were developed, one relating to installation and another relating to materials. Two Florida Test Methods were also developed, one to determine material properties and another to determine bond strengths.</p>					
17. Key Words <b>Adhesive-bonded Anchors, Concrete, Retrofit, Adhesive, Qualification Method, Epoxy, Bond Strength</b>			18. Distribution Statement <b>No restrictions. This document is available to the public through the National Technical Information Service, Springfield, VA, 22161</b>		
19. Security Classif. (of this report) <b>Unclassified</b>		20. Security Classif. (of this page) <b>Unclassified</b>		21. No. of Pages <b>140</b>	22. Price

## **DISCLAIMER**

"The opinions, findings and conclusions expressed in this publication are those of the authors and not necessarily those of the Florida Department of Transportation or the U.S. Department of Transportation.

Prepared in cooperation with the State of Florida Department of Transportation and the U.S. Department of Transportation."

## SI\* (MODERN METRIC) CONVERSION FACTORS

APPROXIMATE CONVERSIONS TO SI UNITS					APPROXIMATE CONVERSIONS FROM SI UNITS				
Symbol	When You Know	Multiply By	To Find	Symbol	Symbol	When You Know	Multiply By	To Find	Symbol
<b>LENGTH</b>					<b>LENGTH</b>				
in	inches	25.4	millimeters	mm	mm	millimeters	0.039	inches	in
ft	feet	0.305	meters	m	m	meters	3.28	feet	ft
yd	yards	0.914	meters	m	m	meters	1.09	yards	yd
mi	miles	1.61	kilometers	km	km	kilometers	0.621	miles	mi
<b>AREA</b>					<b>AREA</b>				
in <sup>2</sup>	square inches	645.2	square millimeters	mm <sup>2</sup>	mm <sup>2</sup>	square millimeters	0.0016	square inches	in <sup>2</sup>
ft <sup>2</sup>	square feet	0.093	square meters	m <sup>2</sup>	m <sup>2</sup>	square meters	10.764	square feet	ft <sup>2</sup>
yd <sup>2</sup>	square yards	0.836	square meters	m <sup>2</sup>	m <sup>2</sup>	square meters	1.195	square yards	ac
ac	acres	0.405	hectares	ha	ha	hectares	2.47	acres	mi <sup>2</sup>
mi <sup>2</sup>	square miles	2.59	square kilometers	km <sup>2</sup>	km <sup>2</sup>	square kilometers	0.386	square miles	
<b>VOLUME</b>					<b>VOLUME</b>				
fl oz	fluid ounces	29.57	milliliters	ml	ml	milliliters	0.034	fluid ounces	fl oz
gal	gallons	3.785	liters	l	l	liters	0.264	gallons	gal
ft <sup>3</sup>	cubic feet	0.028	cubic meters	m <sup>3</sup>	m <sup>3</sup>	cubic meters	35.71	cubic feet	ft <sup>3</sup>
yd <sup>3</sup>	cubic yards	0.765	cubic meters	m <sup>3</sup>	m <sup>3</sup>	cubic meters	1.307	cubic yards	yd <sup>3</sup>
<b>MASS</b>					<b>MASS</b>				
oz	ounces	28.35	grams	g	g	grams	0.035	ounces	oz
lb	pounds	0.454	kilograms	kg	kg	kilograms	2.202	pounds	lb
T	short tons (2000 lb)	0.907	megagrams	Mg	Mg	megagrams	1.103	short tons (2000 lb)	T
<b>TEMPERATURE (exact)</b>					<b>TEMPERATURE (exact)</b>				
°F	Fahrenheit temperature	5(F-32)/9 or (F-32)/1.8	Celcius temperature	°C	°C	Celcius temperature	1.8C + 32	Fahrenheit temperature	°F
<b>ILLUMINATION</b>					<b>ILLUMINATION</b>				
fc	foot-candles	10.76	lux	l	lx	lux	0.0929	foot-candles	fc
fl	foot-Lamberts	3.426	candela/m <sup>2</sup>	cd/m <sup>2</sup>	cd/m <sup>2</sup>	candela/m <sup>2</sup>	0.2919	foot-Lamberts	fl
<b>FORCE and PRESSURE or STRESS</b>					<b>FORCE and PRESSURE or STRESS</b>				
lbf	poundforce	4.45	newtons	N	N	newtons	0.225	poundforce	lbf
psi	poundforce per square inch	6.89	kilopascals	kPa	kPa	kilopascals	0.145	poundforce per square inch	psi

NOTE: Volumes greater than 1000 l shall be shown in m<sup>3</sup>.

\* SI is the symbol for the International System of Units. Appropriate rounding should be made to comply with Section 4 of ASTM E380.

## TECHNICAL SUMMARY

The purpose of this research was to develop specifications and a qualification method for using adhesive products to bond anchors and dowels to hardened concrete. This method will establish the nominal bond strength of an adhesive product and the relative effects of several influence factors. A total of 1308 tests were performed (in two phases) on 20 commercially-available products and two prototype formulations.

The results of the first phase of the test program includes test series for a baseline reference, and for various installation and in-service conditions. Testing during the second phase included additional series for installation and in-service conditions, and long-term service conditions.

In addition to bond-strength testing, a method of adhesive identification (fingerprint) was developed to establish a unique reference set of chemical and physical properties to verify the composition and proportions of a product. The purpose of this "fingerprint" is to infer performance characteristics of an unknown or future production batch of adhesive.

Finally, four draft documents were developed to assist the FDOT in implementing a qualification method. Two Standard Specifications were developed; one relating to installation and another relating to materials. Two Florida Test Methods were also developed; one to determine material properties and another to determine bond strengths.

**SPECIFICATIONS  
FOR  
ADHESIVE-BONDED ANCHORS AND DOWELS**

**By  
Ronald A. Cook  
Robert C. Konz  
Daniel S. Richardson**

**Department of Civil Engineering  
College of Engineering  
University of Florida  
Gainesville, Florida**

**Engineering and Industrial Experiment Station  
September 1996**

## TABLE OF CONTENTS

<b>Chapter 1</b>	<b>Introduction . . . . .</b>	<b>1</b>
1.1	Introduction . . . . .	1
1.2	Problem Statement . . . . .	1
1.3	Scope . . . . .	2
1.4	Objectives . . . . .	2
<b>Chapter 2</b>	<b>Background . . . . .</b>	<b>3</b>
2.1	General . . . . .	3
2.2	Product Variability . . . . .	3
2.3	Influence Factors . . . . .	4
<b>Chapter 3</b>	<b>Development of the Test Program . . . . .</b>	<b>5</b>
3.1	General . . . . .	5
3.2	Performance Characteristics . . . . .	5
3.2.1	Characteristic Bond Strength . . . . .	6
3.2.2	External Influence Factors . . . . .	7
3.2.2.1	Installation Conditions . . . . .	7
3.2.2.2	Service Conditions . . . . .	11
3.2.3	Nominal Bond Strength . . . . .	13
3.3	Method for Performing Adhesive Identification . . . . .	14
3.4	Appropriate Test Methods . . . . .	15
3.5	Development of Working Documents for Implementing Qualification Methods . . . . .	16
<b>Chapter 4</b>	<b>Implementation of the Test Program . . . . .</b>	<b>17</b>
4.1	General . . . . .	17
4.2	Apparatus . . . . .	17
4.2.1	Specimen Preparation . . . . .	17
4.2.2	Anchor Installation . . . . .	18
4.2.3	Data Management and Acquisition . . . . .	18
4.2.4	Measurement . . . . .	19
4.2.5	Instrument Calibration . . . . .	20
4.2.6	Environmental Control . . . . .	20

	4.2.7	Load Application . . . . .	21
	4.2.7.1	Single Anchor, Confined and Unconfined	21
	4.2.7.2	Long-Term Load (Creep) . . . . .	21
	4.2.8	Miscellaneous . . . . .	22
4.3		Specimen Preparation . . . . .	23
	4.3.1	Concrete Test Members . . . . .	23
	4.3.2	Anchor Rods . . . . .	24
	4.3.3	Adhesive . . . . .	24
4.4		Installation Procedure . . . . .	24
	4.4.1	Uncleaned Hole . . . . .	26
	4.4.2	Damp-Hole Installation . . . . .	26
	4.4.3	Submerged Installation . . . . .	27
	4.4.4	Horizontal Orientation . . . . .	27
	4.4.5	Concrete Strength (Low) . . . . .	27
	4.4.6	Concrete Strength (High) . . . . .	27
	4.4.7	Concrete Aggregate . . . . .	28
	4.4.8	Short-Term Cure . . . . .	28
	4.4.9	Elevated Temperature . . . . .	28
	4.4.10	Long-Term Load (Creep) . . . . .	28
4.5		Loading Procedure . . . . .	29
	4.5.1	Confined and Unconfined Tension Tests (Except Creep) . . . . .	29
	4.5.2	Long-Term Load (Creep) . . . . .	29
4.6		Data Reduction . . . . .	30
	4.6.1	Bond Strength Failure Criteria . . . . .	30
	4.6.1.1	Stiffness . . . . .	31
	4.6.1.2	Strength . . . . .	31
	4.6.1.3	Displacement . . . . .	31
Chapter 5		Test Results . . . . .	32
Chapter 6		Discussion of Test Results . . . . .	35
	6.1	Uniform Bond Stress Assumption . . . . .	35
	6.2	Development of a "Design" Adhesive . . . . .	35
	6.2.1	Balance Between Strength and Availability . . . . .	37
	6.3	Discussion of Individual Test Series . . . . .	44
	6.3.1	Additional Baseline Tests and Retests . . . . .	44
	6.3.2	Unconfined Tension . . . . .	44

6.3.3	“Mandatory” Influence Factors . . . . .	44
6.3.3.1	Damp-Hole Installation . . . . .	44
6.3.3.2	Elevated Temperature . . . . .	45
6.3.3.3	Horizontal Orientation . . . . .	45
6.3.3.4	Short-Term Cure . . . . .	46
6.3.3.5	Long-Term Load (Creep) . . . . .	46
6.3.4	“Optional” Influence Factors . . . . .	47
Chapter 7	Summary, Conclusions, and Recommendations . . . . .	48
7.1	Summary . . . . .	48
7.2	Conclusions . . . . .	49
7.3	Recommendations . . . . .	50
Appendix A	Failure Load Data and Load-Displacement Graphs (Phase II) . . . . .	51
Appendix B	Florida Standard Specification Section 4XX -- Installing Adhesive-Bonded Anchors and Dowels (Preliminary Draft) . . . . .	124
Appendix C	Florida Standard Specification Section 9XX -- Adhesive-Bonded Anchors and Dowels (Preliminary Draft) . . . . .	127
Appendix D	Florida Test Method for Anchor System Tests for Adhesive-Bonded Anchors and Dowels, Designation: FM X-XX (Preliminary Draft) . . . . .	132
Appendix E	Florida Test Method for Material Properties Identification of Adhesive-Bonded Anchors and Dowels, Designation: FM Y-YY (Preliminary Draft) . . . . .	136
References	. . . . .	140

## 1. CHAPTER ONE -- INTRODUCTION

### 1.1 INTRODUCTION

Adhesive-bonded anchors are increasingly being used as structural fasteners for connections to hardened concrete. Advances in materials technology and increasing confidence through experience have encouraged the development of a wide variety of new and changing products. Because of their reliance on chemical bond more than mechanical interlock, adhesive-bonded anchors are uniquely susceptible to a number of potentially adverse influence factors typical of common installation and in-service conditions.

Given the current understanding, reliability of bonded anchors cannot easily be assured without comprehensive testing of specific products.

### 1.2 PROBLEM STATEMENT

A qualification method arose from a need to better evaluate adhesive-bonded anchors proposed for use in Florida Department of Transportation (FDOT) construction projects. A number of products are currently available; some are already included in the Qualified Products List (QPL) and others seek recognition. New products may emerge from advances in technology or changes in current formulations. For these reasons, an objective method of evaluation will provide a benefit to the FDOT.

Second, designers must currently rely on recommendations and data from individual manufacturers. Independent test results are available for some products, but with two potential concerns. The conditions under which testing was performed may not accurately reflect the needs of the FDOT, and direct comparison of products tested under different programs may be limited due to variations between test procedures. An appropriate

qualification method can provide objective means to establish realistic design values.

### 1.3 SCOPE

The scope of this qualification program was limited to the investigation of product-specific adhesive bond strengths and the relevant influence factors for FDOT typical projects. The investigation included epoxies (amines and mercaptans), polyesters, and vinyl esters among 22 products. Twenty products are commercially available (A through T) and two are prototype formulations (X and Y). All products were two-part chemical compounds with packaging or dispensing systems that automatically proportion and mix both components.

Applications of these products include tension connections to hardened, uncracked concrete, but are limited to drilled hole diameters approximately 10 to 20 percent larger than the anchor rod. This would exclude grouted anchors, which are typically cementitious products with large hole size-to-anchor diameter ratios.

### 1.4 OBJECTIVES

Four basic objectives were identified for this program:

- Determine product-specific performance characteristics,
- Develop a method for performing adhesive identification
- Identify appropriate test methods for qualification, and
- Develop draft documents to assist the FDOT in implementing qualification methods.

## 2. CHAPTER TWO -- BACKGROUND

### 2.1 GENERAL

Tension loads are transferred from an anchor rod to the concrete base material through an adhesive bond between the surfaces of an anchor rod and a drilled hole. Applied loads other than tension (shear and compression) are transferred directly to the concrete base material through bearing contact, basically independent of the bond strength. Other design considerations such as distance to a free edge and anchor spacing may depend on the bond strength but can be investigated through single anchor tests. Although edge distance and group effects should be considered for design, they offer little or no benefit in distinguishing between specific products. Therefore, the results for these qualification methods were obtained with tension tests on single anchors located away from a free edge.

### 2.2 PRODUCT VARIABILITY

Most current products can generally be categorized as epoxies (amines and mercaptans), polyesters, vinylesters, and hybrid variations. Other categories may exist or be developed in the future. However similar in chemical composition, the response of each product to various influence factors can vary widely. Some general trends seem apparent, but significant overlap between categories leaves little confidence in predictions based simply on the chemical grouping.

Over time, manufacturers may change the formulations of their products, usually reacting to market demands, or advances in technology. Reformulation may include altering the components, proportions, or both. Variations may also occur within products

of the same formulation, possibly from processing tolerances or packaging. Whether the changes are intentional or not, the resulting change in performance may be dramatic.

### 2.3 INFLUENCE FACTORS

Influence factors can be categorized as internal and external. Internal factors are those that influence anchor performance due to variables such as chemical formulation, production processing, and packaging. Chemical formulation includes the selection of components and their proportions. Production processing includes the effects of manufacturing such as tolerances in proportioning. Packaging includes the effectiveness of the dispensing device in delivery of the proper proportions and mixing uniformity. Internal influence factors are generally beyond the control of the end user, but the resulting effects on anchor performance can be significant.

External factors are basically those variables beyond the direct control of the manufacturer and exclusive of the formulation, production, or packaging of the product. Examples include installation and curing conditions, the base material into which the product is installed, the rate and duration of loads, and long-term exposure effects during the service life of the anchor.

### 3. CHAPTER THREE -- DEVELOPMENT OF THE TEST PROGRAM

#### 3.1 GENERAL

This program was part of a larger program that also included the development of a design method for adhesive-bonded anchors. Physical tests relating to installation conditions were performed in an initial phase [1]. The results presented in Appendix A of this report represent a subsequent phase including tests relating to additional installation conditions, long-term effects, anchor geometry, and service strength. External influence factors relevant to the qualification methods were investigated during both phases.

#### 3.2 PERFORMANCE CHARACTERISTICS

The first basic objective for this program was to measure the behavior of bonded anchors through applicable performance characteristics. These were determined through three basic steps using single anchor specimens:

1. A characteristic bond strength (baseline) was determined for anchor specimens installed in "ideal" conditions including:
  - FDOT Class II concrete with limestone aggregate aged 28 days,
  - holes drilled and cleaned in general accordance with the manufacturer's instructions,
  - vertical installation into dry holes,
  - seven-day curing period, and
  - short-duration tension load at room temperature.

Measured performance was based on static tension tests of confined specimens.

2. External influence factors were determined with appropriate deviations from ideal conditions through individual test series. Measured performance was based on static tension tests of confined specimens. The effect of each influence factor was compared to the corresponding baseline series.
3. A nominal bond strength was determined for anchor specimens installed in ideal conditions. Measured performance was based on static tension tests of unconfined specimens. For design, the nominal bond strength would be adjusted by multiplying the relative effects of applicable influence factors.

### 3.2.1 CHARACTERISTIC BOND STRENGTH

To evaluate the relative effects of external influence factors on bond strength, a reference baseline (characteristic bond strength) was determined with a *Confined Tension* test series. Specimens were loaded such that the reaction was sufficiently close to the anchor to preclude concrete failure, but allow bond failure over the entire embedment depth. This was accomplished by “confining” the test specimens with a steel bearing plate such that the projection of the anchor passed through a slightly oversized hole. A compression reaction from the load source was transferred through a narrow load frame bearing directly on the confining plate (Figure 1). This test series was performed in the initial phase of the testing program [1] but three products were retested in this subsequent phase. Two additional products (X and Y) were also tested in this subsequent phase.

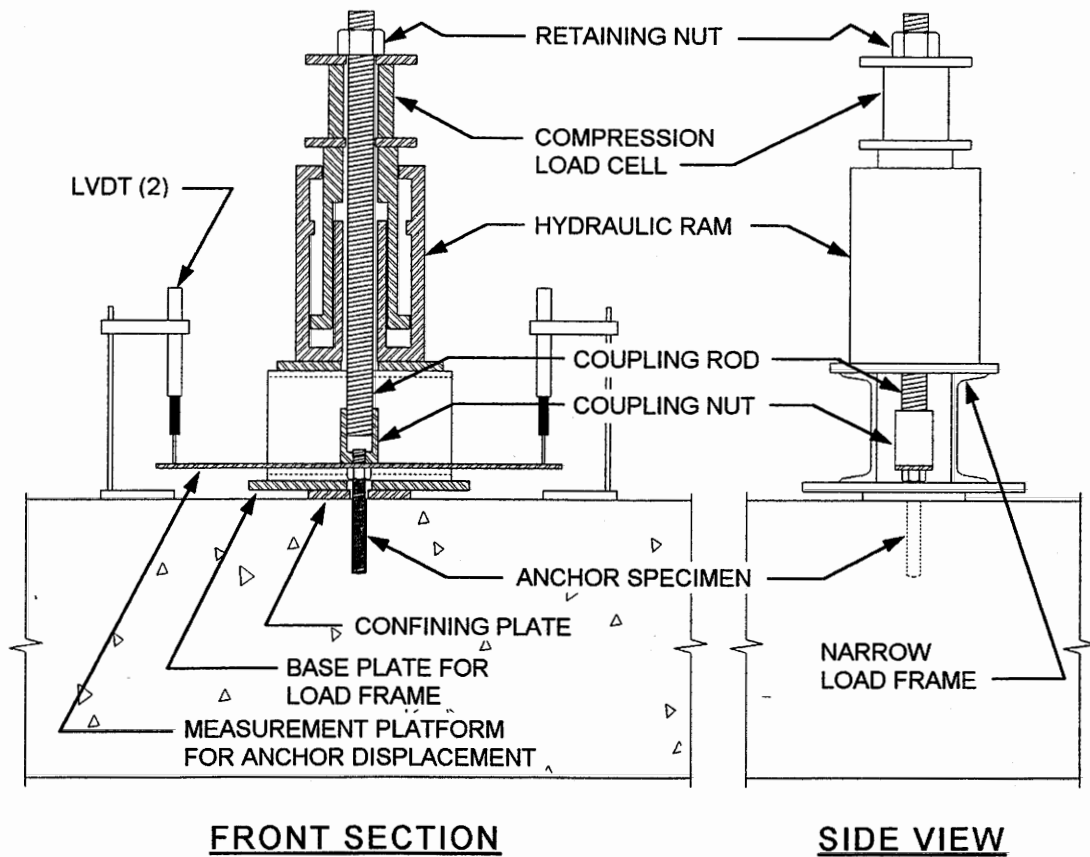

Figure 1. Testing Apparatus for Confined Specimens

### 3.2.2 EXTERNAL INFLUENCE FACTORS

Two groups were investigated: installation conditions, and service conditions.

#### 3.2.2.1 INSTALLATION CONDITIONS

This group of influence factors included independent test series investigating:

- three cases of hole condition: uncleaned, damp, and wet (submerged),
- one case of hole orientation: horizontal, and
- three cases of base material: low-strength concrete, high-strength concrete, and river gravel coarse aggregate.

**UNCLEANED HOLES** -- Proper cleaning of the drilled hole is critical to bonded anchor performance. The drilling process will leave loose concrete particles on the inside surface of the hole, creating a partial bond-breaker. The objective of cleaning is to improve the potential bond surface by removing these particles with compressed air and a bristle brush. Some minor variations exist among manufacturer's instructions, but a typical procedure would require:

1. using compressed air to remove loose particles from drilling,
2. brushing the inside surface to liberate loose particles trapped in exposed pores,
3. using more compressed air to remove those additional particles.

Although partial cleaning may occur in field installations, this test series was intended to model the worst case where no attempt was made to clean the hole. This test series was performed in the initial phase of the testing program [1] but, in general, specimens were installed in accordance with the manufacturer's instructions except that the inside of the drilled hole remained undisturbed after the drill bit was removed.

A clarification should be made with respect to terminology used the initial testing phase of this program. It should be noted that the term "dirty" refers to an uncleaned hole. Further, the terms "uncleaned" and "dirty" have the same meaning and both exclude holes contaminated by foreign matter or loose particles from a nearby hole.

**DAMP-HOLE INSTALLATION** -- The presence of moisture during installation can influence the performance of a bonded anchor system primarily by either displacing adhesive in exposed pores within the concrete surface, or by impeding the chemical reaction taking place during curing. This test series was intended to model applications

where a properly cleaned hole becomes saturated with water but is relieved of freestanding water just prior to installation.

It should be noted that this test series investigated conditions where hole cleaning is completed in a dry hole prior to the introduction of any water, and that water is not used to "clean" the hole. A distinction should also be made that this test series was limited to the influence of potable water. The influence of other liquids including non-potable water are beyond the scope of this program.

**SUBMERGED INSTALLATION** -- This test series was performed in the initial phase of the test program [1] but, in general, was performed similar to *Damp-Hole Installation* except freestanding water was not removed during installation or curing.

A clarification should be made with respect to terminology used in the initial testing phase of this program. It should be noted that the term "wet-hole" refers to a submerged installation. It should also be noted that the same limitations relating to potable water apply as for *Damp-Hole Installation*.

**HORIZONTAL ORIENTATION** -- For applications where the anchor must be installed other than vertically downward, a significant potential for reduced bond strength exists due to flowout of the adhesive from the drilled hole. For a horizontal orientation (installation perpendicular to a vertical face), settlement of the anchor against the lower surface of the hole can result in a nonuniform thickness of the adhesive layer and the bonded surface area can be interrupted by the formation of air cavities along the upper surface. For an overhead orientation (a vertical hole but directed upward), similar flowout problems can occur but anchor settlement results in outward movement. This outward

movement would reduce the effective depth of embedment and therefore the bonded surface area. However, previous research [2] has concluded that "installation position (vertical, horizontal, or overhead) for paste-like adhesives has no effect on anchor behavior."

This test series investigated two prototype formulations that both exhibited relatively low viscosity in contrast to the other tested products. *Confined Tension* and *Damp-Hole Installation* tests were also performed on these products using the same procedure as for the commercially-available products.

**CONCRETE STRENGTH** -- Many aspects of concrete behavior can be related to the compressive strength of the concrete, including the performance of cast-in-place and mechanical retrofit anchors. For typical structural applications in FDOT projects, bonded anchors would be used in concrete meeting Class II requirements. Some applications may be equally justified in high-strength concrete typically used for precast, prestressed construction. Few applications would be anticipated in low-strength concrete typically used for non-structural applications.

This test series was performed in the initial phase of the test program [1] but, in general, the first series used test members constructed from low-strength (Class I) concrete. The second series used test members constructed from high-strength (Class IV) concrete. In both series, crushed limestone was used as a coarse aggregate.

**CONCRETE AGGREGATE** -- The compressive strength of concrete is influenced, in part, by the type and strength of coarse aggregate. Crushed limestone is commonly used in Florida due to its local abundance. Although limestone is a relatively weak aggregate,

the final concrete product is usually satisfactory in terms of strength and cost. A typical alternative to limestone is river gravel.

This test series was performed in the initial phase of the test program [1] but, in general, test members were constructed from medium-strength (Class II) concrete with river gravel coarse aggregate.

### 3.2.2.2 SERVICE CONDITIONS

The other basic group of external influence factors included post-installation conditions. In an accelerated construction schedule, bonded anchors may be loaded soon after installation. Other less immediate loadings include both short- and long-term durations. For the relatively warm climate of Florida, the effects of elevated temperature on anchor performance is also relevant. This group of influence factors includes independent test series investigating: *Short-Term Cure, Elevated Temperature, and Long-Term Load (Creep)*.

**SHORT-TERM CURE** -- During the curing process, a chemical reaction proceeds, in part, as a function of temperature and time. Although selection of adhesive components, proportions, and mixing efficiency may also affect reaction rates (and therefore curing times), these internal influence factors are beyond the scope of this program.

This test series was performed in the initial phase of the test program [1] but one product (K) was retested in this subsequent phase. In general, installation, curing, and loading were similar to the baseline tests (*Confined Tension*) except test loads were applied 24 hours after installation.

**ELEVATED TEMPERATURE** -- During the service life of a bonded anchor,

environmental conditions may impose sufficient heat to significantly elevate the temperature of the base material (and the cured adhesive). The influence of elevated temperature on bond strength was investigated by static tension tests on confined anchor specimens installed and cured at room temperature, and then loaded at an elevated temperature of 110 degrees Fahrenheit.

LONG-TERM LOAD (CREEP) -- Some displacement of a bonded anchor is expected under a tension load; a function of the stiffness of the anchor and the adhesive. However, additional displacement may continue under sustained loads due to creep. If the rate of additional displacement does not decrease, unacceptable anchor displacement is inevitable.

Since material properties of thermosetting plastics may vary with a relatively mild temperature change, the displacement response to a sustained load (creep) may be aggravated when combined with an elevated temperature. It was therefore considered relevant to perform long-term load (creep) at an elevated temperature representative of anticipated service conditions.

Displacement, not bond strength, was the focus of this test series, so a typical service load was necessary for the duration of the test. This reference load was determined as 40 percent of the mean value obtained from a *Confined Tension* test series performed at room temperature.

Four products were selected for test specimens, one from each of the basic adhesive categories: epoxy-amine, epoxy mercaptan, polyester, and vinylester (vinylester-cementitious hybrid). Due to the complexity of the test apparatus, only three replicate specimens were tested for each product.

### 3.2.3 NOMINAL BOND STRENGTH

While confined testing may provide an efficient method for evaluating bond strength, few practical applications behave as confined. In typical applications, the reaction from the applied load originates away from the immediate vicinity of the anchor. This differs from the confined condition where the reaction is applied immediately adjacent to the anchor.

When a bonded anchor is not confined, typical failure modes (exclusive of the anchor rod) appear to include fracture of the concrete in the form of an inverted cone. For relatively shallow embedments, the tip of the cone may initiate at or near the bottom of the hole, a "full-depth" cone. For deeper embedments, the depth of the cone is some fraction of the embedment depth. Regardless of the cone depth or its possible influence on total system strength, unconfined strengths more accurately represent typical applications and are generally less than confined strengths for the same bond surface area. Therefore, a nominal bond strength (*Unconfined Tension*) was investigated to help develop useable design values.

Test specimens were loaded such that the reaction was sufficiently far away from the anchor to allow a concrete cone to form. This was accomplished by transferring a compression reaction from the load source to the concrete with a wide load frame fabricated from structural steel shapes (Figure 2). Anchor spacing and minimum edge distances were to accommodate relatively large concrete fractures (cones).

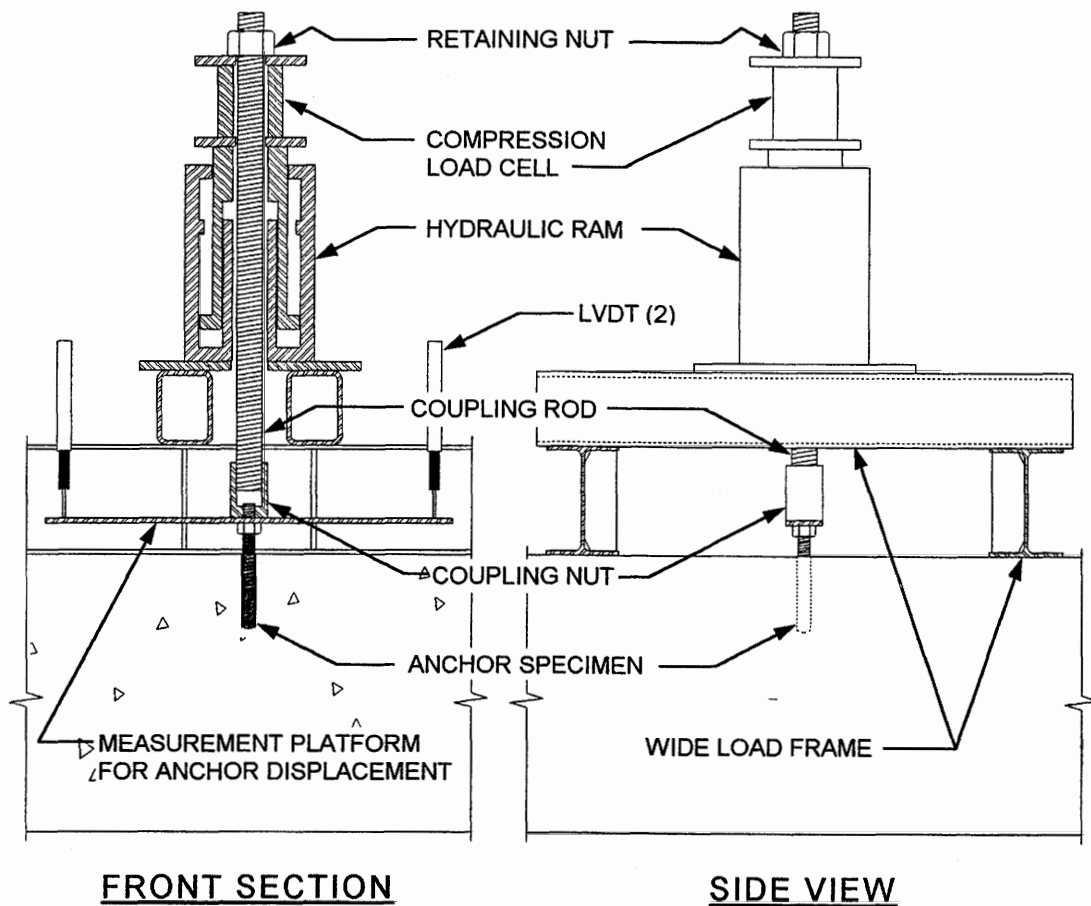

Figure 2. Testing Apparatus for Unconfined Specimens

Although some limited testing was performed in the initial phase of the testing program, the full series was retested in this subsequent phase but was limited to two commercially available products that exhibited relatively low coefficients of variation in *Confined Tension* tests.

### 3.3 METHOD FOR PERFORMING ADHESIVE IDENTIFICATION

The second basic objective of this qualification program was to develop a set of chemical and physical properties, a "fingerprint," to verify the composition and proportions of a specific product. With this fingerprint, a reasonable inference of product

performance can be made for future or questionable samples by comparing fingerprints between a qualified batch and an untested sample.

Much effort has been made by other organizations in developing acceptance criteria for this topic. The ICBO Evaluation Service, Inc. (a subsidiary of the International Conference of Building Officials) publishes *Acceptance Criteria for Adhesive Anchors in Concrete and Masonry Elements* [3]. Within their requirements for test specimen description are methods to establish a standard fingerprint for quality control audits.

The Concrete Anchor Manufacturer's Association (CAMA) has established various committees to offer information to various approval agencies, including additional recommendations for ICBO AC58 titled *Procedure for Performing Adhesive Identification* [4].

A method for performing adhesive identification was developed from the ICBO and CAMA documents and is presented in Appendix E.

#### 3.4 APPROPRIATE TEST METHODS

The third basic objective of this qualification program was to identify appropriate testing methods that would be reproducible, necessary, and efficient. Without reproducibility, uncertainty would dominate any confidence that laboratory tests would accurately represent field applications. For this reason, existing recognized standards and methods were incorporated where appropriate.

Applicability of specific influence factors may vary with regional conditions. Conditions of great interest in one location may generate little concern elsewhere. In Florida, testing for response to moisture and elevated temperatures may be useful, while

seismic and freeze/thaw testing might offer only limited benefits. Test methods most appropriate to conditions encountered in FDOT projects were considered.

Inefficient test methods will ultimately increase the cost of construction projects through increased costs of testing. Large concrete spalls and sometimes unpredictable fractures associated with unconfined testing may require five to ten times the amount of concrete surface area, or more, than for confined testing. Test methods utilizing confined specimens were developed to promote efficiency in the use of materials while still producing valid results.

### 3.5 DEVELOPMENT OF WORKING DOCUMENTS FOR IMPLEMENTING QUALIFICATION METHODS

The fourth basic objective was to assist the FDOT in developing working documents to implement qualification methods. These working documents include preliminary drafts of two Standard Specification Sections and two Florida Test Methods. The first Standard Specification, Section 4XX (Appendix B) includes requirements for installation. The second, Section 9XX (Appendix C), includes materials requirements. Florida Test Method FM X-XX (Appendix D) describes test methods to determine strength characteristics and the effects of various influence factors. Florida Test Method FM Y-YY (Appendix E) describes test methods to determine a product-specific "fingerprint." All of the documents reference the others as appropriate and the formats are consistent with current FDOT publications.

## 4. CHAPTER FOUR -- IMPLEMENTATION OF THE TEST PROGRAM

### 4.1 GENERAL

Performance characteristics were determined from a comprehensive testing program involving twenty commercially available products and two prototype products. Tests were performed in general accordance with applicable sections of ASTM E 1512 [5] and ASTM E 488 [6]. For most series, five replicate specimens were tested for each product. For all test series except *Short-Term Cure*, specimens were cured for seven days. The results of all tests performed in Phase II of this program are presented in Appendix A as summary tables, load-displacement and displacement-time graphs.

### 4.2 APPARATUS

The apparatus for this test program involved specimen preparation, anchor installation, data management and acquisition, measurement, instrument calibration, environmental control, load application, and miscellaneous items.

#### 4.2.1 SPECIMEN PREPARATION

Adhesive anchor systems included three basic components; concrete test members, anchor rods, and adhesive. Wood forms were constructed and assembled using basic carpentry hand tools. Steel reinforcement consisted of straight bars cut to length with an oxygen-acetylene torch. Basic concrete placing and finishing tools were used including an electric vibrator, standard slump cone, and 6" x 12" plastic cylinder molds.

Steel anchor rods were fabricated with a portable band saw and bench grinder. Lacquer thinner and plain brown paper were used to clean and protect fabricated rods.

#### 4.2.2 ANCHOR INSTALLATION

Depending on the required hole diameter, one of two rotary hammer drills were used, model TE-22 or TE-52, both manufactured by Hilti, Inc. Carbide-tipped concrete bits of various diameters and lengths were also manufactured by Hilti, Inc. A small wooden frame with a steel pipe sleeve was custom fabricated as a drilling guide.

Most adhesive products required proprietary dispensing tools provided by the adhesive manufacturer. The injection systems used cartridge guns with dual plungers. Encapsulated systems simply used a rotary drill in conjunction with double hex nuts.

#### 4.2.3 DATA MANAGEMENT AND ACQUISITION

During the application of test loads, several measurements were simultaneously recorded at regular intervals while real-time feedback was monitored for load and displacement control. An integrated system controller coordinated sampling and recording rates, measurement recording, and real-time feedback display. A Hewlett-Packard Data Acquisition/Control Unit, model 3852A, was used with the following accessory components:

- 20-channel high speed voltage relay multiplexer, model HP 44705H
- Dual output power supply, model HP 6234A
- Power supply, model HP 6215A
- 20-channel FET multiplexer with thermocouple compensation, model HP44710 A
- Digital Voltmeter, model HP 4470A or model HP 3466A

An IBM-compatible personal computer was interfaced with the Data

Acquisition/Control Unit using software by Autonet (versions 4.0 and 4.2). The computer was also used to download and reduce the acquired data.

#### 4.2.4 MEASUREMENT

Measured values included time, load, displacement, and temperature. Time was necessary to control loading rates and to coordinate simultaneous load, displacement, and temperature measurements. Sampling rates were relatively slow (approximately 2 measurements per second) so the computer system clock was adequate.

Applied tension load was measured indirectly as a compression reaction of the load source. For *Long-Term Load (Creep)*, 50-kip compression load cells were used. For all other tests, a 200-kip compression load cell was used. The 50-kip load cells were aluminum-bodied units fabricated and calibrated at the University of Florida testing facility. The 200-kip load cell was manufactured by Houston Scientific, model 3500-200K.

For single anchor specimens, direct measurement of axial displacement was obstructed by the loading apparatus, so an instrument platform was used to provide a reference frame away from the specimen (Figures 1,2, and 3). The platform, fabricated from ASTM A 36 steel flatbar, was secured to the projection of the anchor specimen between the coupling nut above, and a hex nut below. Two LVDTs were located (one at each end) equal distances from the anchor specimen. The displacement of the anchor was calculated as the average of the two LVDT measurements. The LVDTs were manufactured by Schaevitz, type GCD-121-500.

During installation, the Data Acquisition/Control Unit was not used and temperature

was measured with a thermistor-type electronic thermometer manufacturer by Fisher Scientific. During load application, temperatures were measured with a type "T" thermocouple probe controlled and recorded by the HP Control unit.

#### 4.2.5 INSTRUMENT CALIBRATION

The instruments used to measure displacement and load were calibrated at the University of Florida testing facility. The LVDTs were calibrated against a Schaevitz micrometer over their full linear range of  $\pm 0.5$  inches in approximately 25 increments.

A Tinius Olson Universal Testing Machine was used to calibrate the Houston Scientific load cell over a range of 1-50 kips in 1 kip increments. The anticipated loads measured by the aluminum-bodied load cells would not exceed 10 kips so their calibration range was limited to 1-10 kips in 500 pounds increments. The Tinius Olson Machine was also used to calibrate and load the compression springs for the *Long-Term Load (Creep)* test series.

#### 4.2.6 ENVIRONMENTAL CONTROL

For series requiring exposure to an elevated temperature, an environmental chamber was constructed with insulated walls, ceiling, and doors. The floor was a concrete slab-on-grade but heat loss was controlled by raising the concrete test members from the concrete floor on wood blocks. The blocks were tall enough to permit sufficient air flow under the test members to maintain a consistent temperature throughout the concrete.

Air temperature inside the environmental chamber was heated with a thermostatically-controlled convection heating unit with electric coils. The heating unit was manufactured by Modine and the thermostat by Honeywell. A thermocouple probe was located inside

the chamber and remotely monitored to confirm the air temperature.

#### 4.2.7 LOAD APPLICATION

##### 4.2.7.1 SINGLE ANCHOR, CONFINED AND UNCONFINED

All test series except *Long-Term Load (Creep)* utilized a center-hole type hydraulic ram as a load source with an electric-powered hydraulic pump providing pressure. The rams and pump were compatible units capable of delivering 200 kips at 10,000 psi. One of the two following equivalent rams were used with a single pump and motor:

- Holl-O-Cylinder hydraulic ram by Enerpac, model RRH 603 (60 ton)
- Simplex hydraulic ram by Templeton Kenly & Co., model R603 (60 ton)
- Series 3000 hydraulic pump by Enerpac, model PER3405 B, with 1.5 hp electric motor by Leeson Electric Corp., model 66K17FZ8C.

##### 4.2.7.2 LONG-TERM LOAD (CREEP)

Test series requiring a sustained load utilized heavy compression springs instead of a hydraulic ram. This was done to simplify the apparatus and to reduce the risk of an unintentional loss of load due to a hydraulic leak. The springs were contained by steel frames custom-fabricated at the University of Florida testing facility (Figure 3).

The steel wire springs were approximately 5.5 inches (140 mm) in diameter by 9 inches (229 mm) long, uncompressed. Two different springs stiffnesses were used, the stiffer springs for the products requiring a higher test load. The respective spring constants were approximately 2.5 kips per inch, and 4 kips per inch.

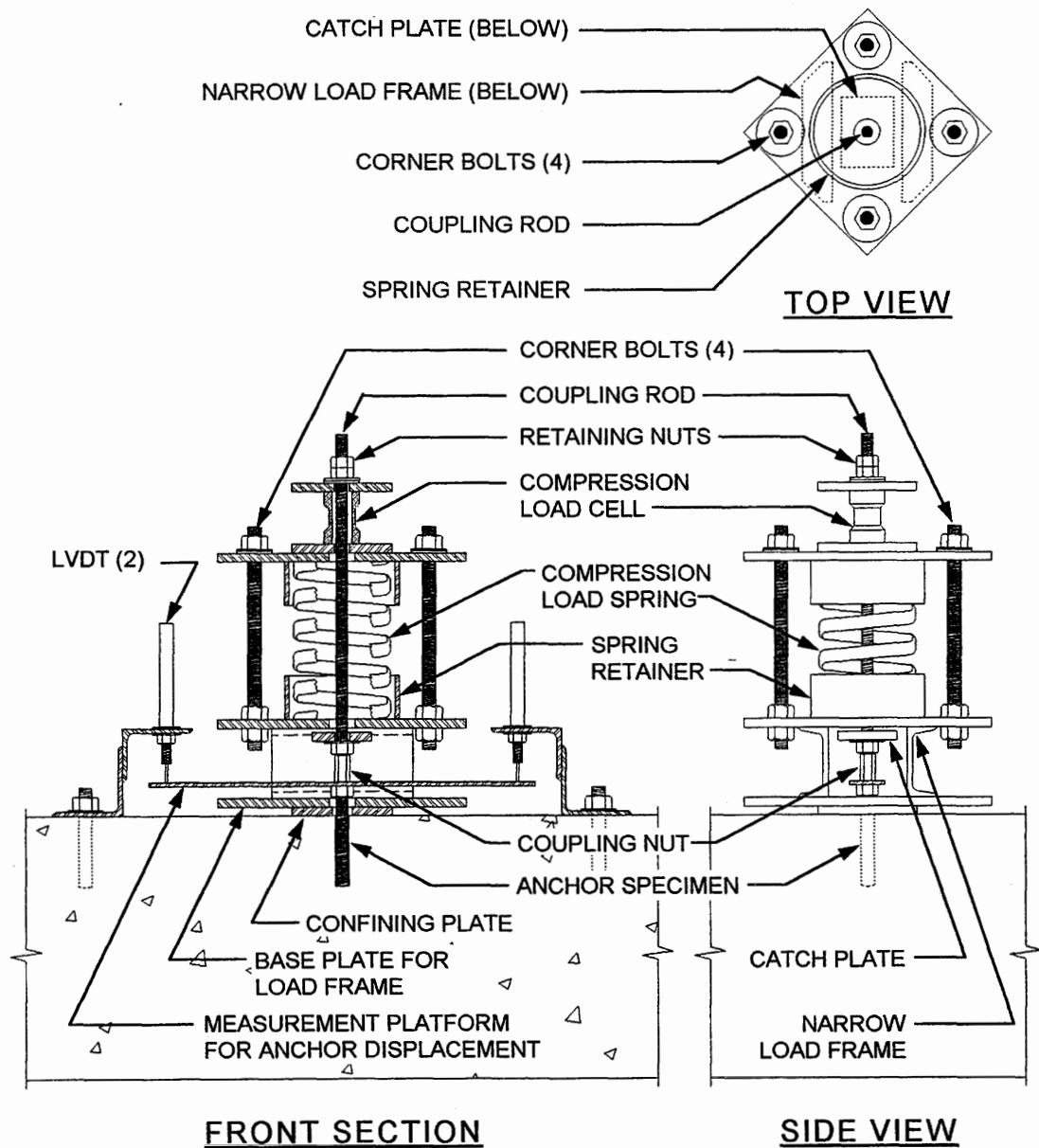

Figure 3. Testing Apparatus for Sustained Load on Confined Specimens

#### 4.2.8 MISCELLANEOUS

Various structural steel shapes were used to fabricate instrument frames and brackets. Heavy-duty C-clamps and laboratory test-tube clamps were used to secure the LVDTs to their frames.

### 4.3 SPECIMEN PREPARATION

#### 4.3.1 CONCRETE TEST MEMBERS

Rectangular concrete test members were cast from forms constructed of wood. Four vertical faces and the bottom surface had a formed finish with the top surface hand-troweled. The inside dimensions of the forms were 48 inches wide by 96 inches long by 15 inches deep. Some half-size test members were constructed by placing a transverse divider in the forms to produce 48" x 46" x 15" members. Reinforcement was only used to accommodate handling and all test members were unreinforced in the potential failure area of the specimens. A single mat of deformed steel reinforcing was installed in the bottom of the member. Some members had the reinforcing mat at mid-depth to make both the top and bottom surfaces available for testing.

The concrete test members were constructed using ready-mixed concrete batched, mixed, and delivered from a single local commercial source engaged in the regular business of providing concrete. The specified proportions and strengths were in accordance with FDOT specifications. Class II structural concrete with a specified compressive strength of 3400 psi at 28 days was used for most test series. In general, the actual concrete strength at testing was significantly higher.

Test members were aged for a minimum of 28 days prior to drilling any holes or imposing environmental conditions. Compressive strengths of the test members were determined using standard 6 inch by 12 inch test cylinders cast at the same time as the test members and tested in general accordance with ASTM C-39.

#### 4.3.2 ANCHOR RODS

Anchor rods were fabricated from high-strength steel conforming to ASTM A 193, Grade B7. This grade has a specified minimum yield strength of 105 ksi and a tensile strength of 125 ksi. Specimens were saw-cut from stock 12-foot lengths to the desired embedment depth plus two to three inches to accommodate a coupling nut and instrument platform. Oblique saw-cuts were made in accordance with the adhesive manufacturer's instructions for encapsulated products requiring a "chisel point" for proper installation. A bench grinder was used to produce a slight bevel on straight-cut ends to remove burrs and to facilitate installation of nuts. Any corrosion or mill scale was removed with a wire wheel. All anchor rods were cleaned with a solvent to remove any residual coatings and allowed to air-dry. Clean paper wrapping protected the anchor rods until installation.

#### 4.3.3 ADHESIVE

Adhesive products were stored in a temperature-controlled environment and inspected for damage prior to installation. Installation and dispensing tools were as recommended or provided by the manufacturer.

#### 4.4 INSTALLATION PROCEDURE

For the baseline (*Confined Tension*) and service strength (*Unconfined Tension*) test series, anchor installation was performed in general accordance with the manufacturer's instructions. Since other test series investigated various influence factors, those specimens were installed with appropriate deviations.

Installation tools were as recommended by the adhesive manufacturers. For injection systems, pressure was applied to the liquid components with a force at the base of the

cartridge using a plunger loaded either manually or pneumatically. One injection-type system used foil wrapping instead of rigid plastic cartridges. The proprietary installation tool employed a rigid plastic sleeve to contain the foil packages to resist bursting under pressure from the plunger.

For injection systems, a small quantity of adhesive was dispensed onto a waste surface until a uniform mixture was observed. Mixed adhesive was injected into the drilled hole by starting at the bottom and maintaining the tip of the dispensing nozzle just below the rising surface. Holes were typically filled to about 60 percent. Anchor rods were slowly inserted into the hole with a twisting motion to encourage adhesive material into the threads. For tests requiring a reaction plate in close proximity to the anchor, excess adhesive ejected from the hole was carefully wiped from around the base of the anchor projection. For the unconfined tests, the reaction plates were away from the anchor so some excess adhesive was allowed to remain. Anchor rods were then plumbed and left undisturbed for the specified curing period.

Encapsulated systems were installed by crushing and mixing the glass capsule inside the hole with a chisel-pointed anchor rod. An intact glass capsule was inserted into the drilled and cleaned hole. One flat washer was temporarily secured to the straight-cut end of an anchor rod between two hex nuts. A six-point socket bit in a drill held the straight-cut end of the anchor rod while the oblique-cut end was slowly driven into the hole with the hammer mode disengaged. Approximately two to three seconds after the anchor rod contacted the bottom of the hole, the drill was stopped and removed. The nuts and washer were immediately removed to prevent a possible torque load later on the cured

specimen. If the test series required confined specimens, excess material ejected from the hole was carefully removed. Finally, the anchor rod was plumbed and left undisturbed for the specified curing period.

#### 4.4.1 UNCLEANNED HOLE

This test series was performed in the initial phase of the testing program [1] and no retests were performed in this subsequent phase.

#### 4.4.2 DAMP-HOLE INSTALLATION

In general, anchor specimens were installed and cured exactly as for baseline (*Confined Tension*) series except the surface of the concrete test member was saturated in the vicinity of the anchor. Holes were drilled and cleaned in general accordance with the manufacturer's instructions. A shallow dam was constructed of dimensional lumber (2x4) around the perimeter of the concrete test member and sealed with silicone caulking. A one-inch depth of clean water was maintained over the drilled holes for a period of seven days. Just prior to installation, all freestanding water was removed in and around the hole with compressed air. During installation, the concrete surface was saturated, but free of standing water.

Groups of 20 specimens were installed at a time (5 replicate specimens of 4 products) to facilitate the removal of freestanding water without losing a saturated surface around the anchor. Small quantities of water were added to any area yet to be installed that did not exhibit a wet surface. After installation and initial set, no attempts were made to maintain the damp condition.

#### 4.4.3 SUBMERGED INSTALLATION

This test series was performed in the initial phase of the testing program [1] and no retests were performed in this subsequent phase. In general, installation was similar to the *Damp-Hole Installation* series except the dam was not removed and the water level was maintained during installation and curing.

#### 4.4.4 HORIZONTAL ORIENTATION

Holes were drilled and cleaned in general accordance with manufacturer's instructions. Prior to installation, test members were reoriented such that the longitudinal axis of the drilled hole was horizontal. Adhesive product was injected into the drilled holes and anchor rods were inserted immediately with a slight twisting motion. No attempts were made to prevent flowout of adhesive or to prevent settlement of the anchor rod against the bottom of the hole. Adhesive material that did flow out of the hole was carefully wiped to maintain a flat surface for the confining plate. After a seven-day curing period, the test member was reoriented to accommodate the test apparatus.

#### 4.4.5 CONCRETE STRENGTH (LOW)

This test series was performed in the initial phase of the testing program [1] and no retests were performed in this subsequent phase. In general, anchor specimens were installed and cured exactly as for baseline (*Confined Tension*) series.

#### 4.4.6 CONCRETE STRENGTH (HIGH)

This test series was performed in the initial phase of the testing program [1] and no retests were performed in this subsequent phase. In general, anchor specimens were installed and cured exactly as for baseline (*Confined Tension*) series.

#### 4.4.7 CONCRETE AGGREGATE

This test series was performed in the initial phase of the testing program [1] and no retests were performed in this subsequent phase. In general, anchor specimens were installed and cured exactly as for the baseline (*Confined Tension*) series.

#### 4.4.8 SHORT-TERM CURE

This test series was performed in the initial phase of the test program [1] but one product (K) was retested in this subsequent phase. In general, anchor specimens were installed and cured exactly as for the baseline (*Confined Tension*) series.

#### 4.4.9 ELEVATED TEMPERATURE

Five replicate specimens were installed at room temperature exactly as for the baseline (*Confined Tension*) series. After a 7-day curing period, test members were relocated to the environmental chamber and subjected to an ambient air temperature of 110° F.

#### 4.4.10 LONG-TERM LOAD (CREEP)

Due to load limitations of the test apparatus, alternative anchor sizes were used: 1/2 inch (12.7 mm) diameter by 3 inches (76.2 mm) embedment. Because of the smaller test specimens, additional baseline (*Confined Tension*) tests were performed to determine a mean failure load at room temperature. These tests were performed in the same test members used for the sustained-load test. Test specimens for the sustained-load test were also installed at the same time to maintain identical curing cycles. Immediately after baseline testing, the test members with the (now fully cured) sustained-load specimens were transferred to the environmental chamber and subjected to an ambient air temperature of approximately 110° F.

## 4.5 LOADING PROCEDURE

### 4.5.1 CONFINED AND UNCONFINED TENSION TESTS (EXCEPT CREEP)

All test series except *Long-Term Load (Creep)* were performed with the same loading procedure. A center-hole hydraulic ram pressurized by an electric pump was used as a load source. Pressure to the hydraulic ram was manually controlled by adjusting bleed valves on the supply and bypass lines. Feedback was displayed on a computer screen in the form of digital displays of load, displacement, time, and temperature with a real-time load-displacement curve. The rate of loading was such that failure was caused in approximately 2 to 5 minutes.

### 4.5.2 LONG-TERM LOAD (CREEP)

Sustained-load tests were performed on confined specimens, but using a compressed spring for a load source instead of a hydraulic ram (Figure 3). After the test members reached the specified temperature (110° F), instrumentation was installed and the compression springs were loaded to 40 percent of the mean value determined from the additional baseline tests. The loaded springs and frames were placed over the anchor specimens and coupling rods with the spring load resisted by the four corner bolts. After the Data Acquisition/Control Unit was engaged and measurement recording initiated the compressed spring loads were transferred to each coupling rod (and anchor specimen) one at a time by sequentially loosening the corner bolts.

The initial data sampling rate during load transfer was once per 5 seconds. After the last specimen was loaded plus one hour, the sampling rate was decreased to once per 5 minutes for the next 2 days, once per 15 minutes for the next 5 days and finally to a rate of

once per hour for the remainder of 42 days (approximately 1000 hours).

After 42 days, any remaining spring loads were transferred back to the corner bolts, relieving the specimens of tension load. The test members (and anchor specimens) were allowed to cool to room temperature after which *Confined Tension* tests were performed with on all non-failed specimens.

## 4.6 DATA REDUCTION

### 4.6.1 BOND STRENGTH FAILURE CRITERIA

Typical design procedures for connections require that both strength and serviceability criteria be satisfied. Strength criteria would typically require the anchor to resist an applied axial load without significant damage to the anchor system or the concrete base material. Serviceability criteria would typically require sufficient stiffness of the anchor system to prevent excessive axial displacement up to the maximum anticipated service loads.

For design, the nominal strength of a bonded anchor system will be the lesser strength of the anchor rod or the adhesive bond. For the adhesive bond, a potential failure surface can occur at the adhesive-steel interface, the adhesive-concrete interface, or some combination of these surfaces. To focus on bond strength, anchor specimens were designed to avoid failure of the anchor rod. A combination of high-strength steel anchor rods ( $f_y = 105$  ksi) with maximum embedment depths of  $h_{ef}/d < 10$  was generally sufficient to develop the adhesive bond.

Although various applications may impose different displacement criteria, a maximum displacement of 0.1 inch (2.5 mm) was assumed sufficient for the purposes of a

qualification method.

As relatively small, short-duration tensile loads are applied to a bonded anchor, the typical load-displacement relationship appears approximately linear. As the load is increased, a level is eventually reached where many products exhibit a significant reduction in stiffness. This transition can be sudden or gradual, and can vary between products, but is generally consistent within a product. The reduced stiffness reflects reserve load capacity apparently due to mechanical interlock at the failure surface rather than bond strength of the adhesive. Therefore, tests were conducted to failure, defined as the first occurrence of three criteria: stiffness, strength, and displacement.

#### 4.6.1.1 STIFFNESS

For the load-displacement plots, a tangent stiffness of 145 kips/inch (5 kN/mm) best defined the stiffness threshold at which most products diverge from linear response. This does not strictly apply to all failure modes and may not apply to all products, but in conjunction with the other failure criteria, generally produces satisfactory results.

#### 4.6.1.2 STRENGTH

The strength criterion was simply the maximum applied tensile load resisted by the anchor over the duration of the test.

#### 4.6.1.3 DISPLACEMENT

If the stiffness and strength criteria were not exceeded after an axial displacement of 0.1 inches (2.5 mm), a serviceability failure was assumed at the applied load for that maximum displacement.

## 5. CHAPTER FIVE -- TEST RESULTS

The results of this test program are presented in Appendix A as summary tables and plots. The plots associated with the *Long-Term Load (Creep)* test series illustrate a displacement versus time relationship. The plots for all other test series illustrate a load versus displacement relationship. Additional data used for this program are included in Reference 1. The designations used for identifying test specimens are basically consistent with those of Reference 1 and as follows:

Each specimen was assigned a unique designation indicating product, test series, anchor diameter, embedment depth, replicate index, and supplemental information where applicable. The designations consist of six or eight characters in the following format:

BBL541v1 where:

- The first character represents the product code, A through T, plus X and Y
- The second and third characters represent the test series where:

BL = Baseline (Confined Tension)

CT = Long-Term Load (Creep) at Elevated Temperature

DA = Damp-Hole Installation

ET = Elevated Temperature

HO = Horizontal Orientation

ST = Short-Term Cure

UM = Unconfined Tension in Medium-Strength Concrete

- The fourth character represents the nominal diameter of the anchor rod in eighths of an inch where:

4 = 1/2 inch (12.7 mm)

5 = 5/8 inch (15.875 mm)

6 = 3/4 inch (19.05 mm)

- The fifth character represents the embedment depth in inches where:

3 = 3 inches (76.2 mm)

4 = 4 inches (101.6 mm)

5 = 5 inches (127 mm)

6 = 6 inches (152.4 mm)

- The sixth character represents the replicate specimen index for a test series
- The seventh and eighth characters, where applicable, indicate supplemental information where:

BL = Baseline (*Confined Tension*) or for determining a test load for use in *Long-Term Load (Creep)* tests

CT = Confined Tension test subsequent to *Long-Term Load (Creep)*

v# = Retest to verify previous tests where # represents the index of the retest for multiple retests

Figure 4 (a) shows a typical load-displacement plot and Figure 4 (b) shows a typical displacement versus time plot.

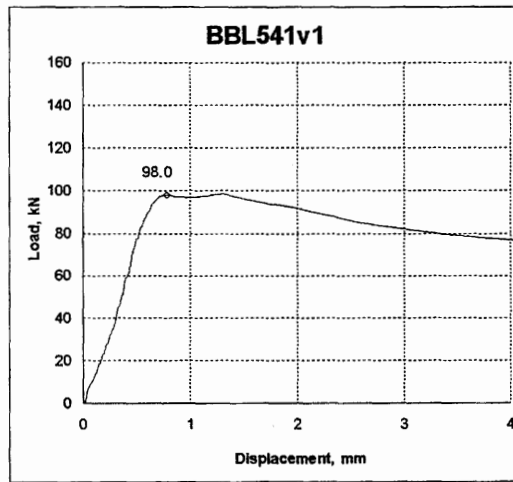

Figure 4 (a) - Typical Load-Displacement Plot

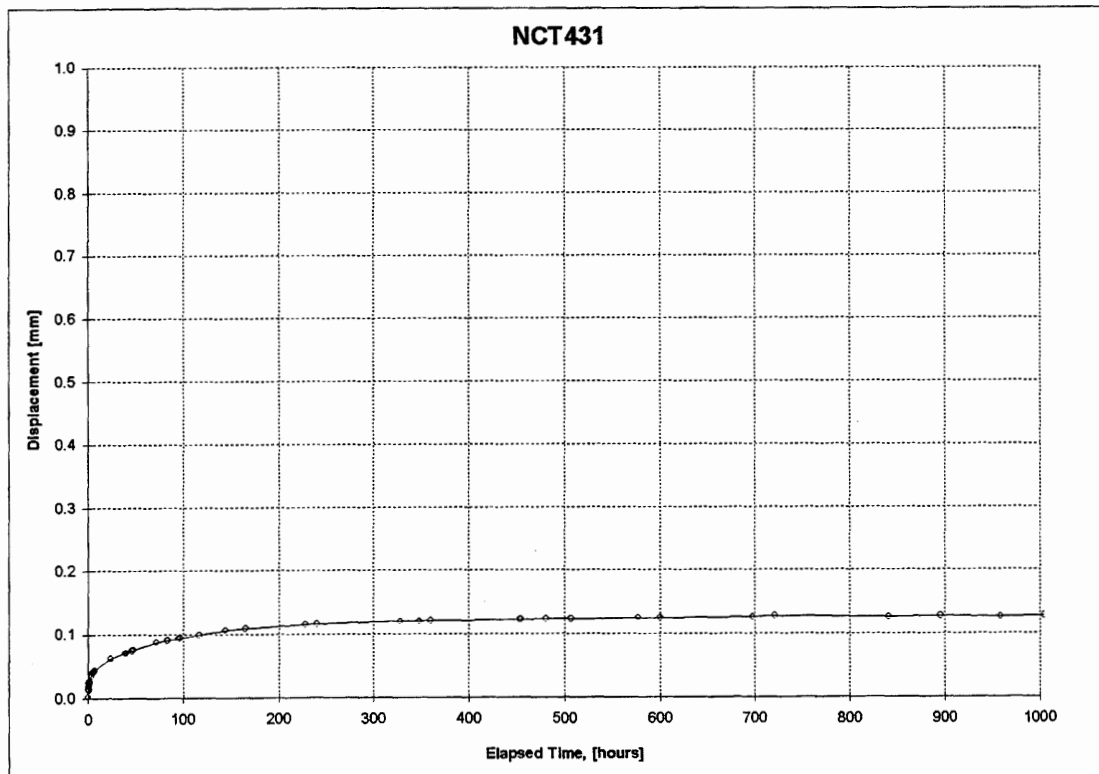

Figure 4 (b) - Typical Displacement vs. Time Plot

## 6. CHAPTER SIX -- DISCUSSION OF TEST RESULTS

### 6.1 UNIFORM BOND STRESS ASSUMPTION

Several proposed design models for bonded anchors subjected to tensile loads have been published recently. Excepting anchor rod failure, predicted anchor strength is based on one of three failure mechanisms: concrete strength, adhesive bond strength, or some combination of both.

While the actual behavior of bonded anchors is still debated, a simple, user-friendly model assuming uniform stress over the entire depth of the bond is proposed by Cook, et al [7]. When the predicted strengths of the various models were compared to tested values from a worldwide database, the uniform bond stress (UBS) model produced the best fit. For this reason, the acceptance criteria proposed in this program assumes a UBS model.

For bond areas associated with smaller anchors (less than 5/8" diameter), the UBS model seems to slightly under-predict the test data. Therefore, with the exception of the creep tests, anchor specimens smaller than 5/8" are not recommended.

### 6.2 DEVELOPMENT OF A "DESIGN" ADHESIVE

The identity of an adhesive product used for construction may not be known during the design phase. Therefore a "design" adhesive was established, which is not a real product but represents the acceptance criteria for qualification. Using these performance levels, the designer is assured of an adequate bond strength among the qualified products.

With an approach similar to the proposed drafts of ASTM Z5818Z, *Performance of Anchors in Uncracked Concrete Elements* [8] and ACI 318, Chapter 23 -- *Fastening to*

*Concrete* [9], the nominal strength of an anchor is determined through testing. The ASTM document identifies test methods to determine a class of anchor based on installation safety, contact with reinforcement, and functioning in both low- and high-strength concrete. After a class of anchor is determined, the ACI document prescribes appropriate capacity reduction factors to be used for design.

Although these documents address only cast-in-place and mechanical retrofit anchors, the basic principle was extended to include adhesive-bonded anchors. The primary difference between the ASTM/ACI method for mechanical anchors and this proposed modification for bonded anchors is the mechanism used to resist tensile loads. Where mechanical anchors rely on a concentrated interlock between the anchor and concrete, bonded anchors transfer the load over the entire contact surface.

Another difference between mechanical and bonded anchors is their response to variations in drilled holes. For a mechanical anchor to properly engage the surrounding concrete, a precise diameter hole is required, particularly in the proximity of the holding device. For installations where the drilled hole makes contact with reinforcement, the mechanical interlock may be compromised. While bonded anchors also rely on a proper diameter hole, load transfer over the entire embedment depth is more forgiving to incidental contact with reinforcement. As a result, testing bonded anchors for *Contact with Reinforcement* [8] provides little or no benefit and was considered to be not relevant for this qualification program.

A third difference between mechanical and bonded anchors is their response to concrete strength. Mechanical anchors derive their strength directly from the concrete's

resistance to fracture, a function of the concrete strength. However, the overall effect of concrete strength on the capacity of bonded anchors is negligible for most products [1]. For this reason, tests for *Functioning in Low- and High-Strength Concrete* also provide little or no benefit and were excluded in the proposed qualification method.

The influence factors affecting bonded anchors include installation (*Damp-Hole Installation* and *Horizontal Orientation*) and in-service effects (*Short-Term Cure* and *Elevated Temperature*). For these factors, the mean values for the corresponding test series were compared to the characteristic bond strength (baseline). This ratio of influence factor-to-baseline is similar to the load reduction ratio,  $\alpha$ , used in Z5818Z.

#### 6.2.1 BALANCE BETWEEN STRENGTH AND AVAILABILITY

An aggressive effort to maximize design values coupled with a particular combination of influence factors could result in few or no qualified products. Therefore, a basic objective for establishing the acceptance criteria values was to strike a balance between maximizing bond strengths and maintaining a reasonable selection of available products.

Using the results of this test program and the principles of the modified ASTM/ACI method, a single class of bonded anchor requirements was developed. A computer spreadsheet was used to discover an optimum combination of acceptance criteria.

For the acceptance criteria indicated in Appendix C, the proposed minimum uniform bond stress for baseline (*Confined Tension*) tests is 2.29 ksi (15.8 MPa). Chart 1 summarizes the characteristic bond strengths (baseline) for all products. Charts 2, 3, and 4 summarize the bond strengths for the influence factors. *Horizontal Orientation* is not shown since only two products were tested in this program.

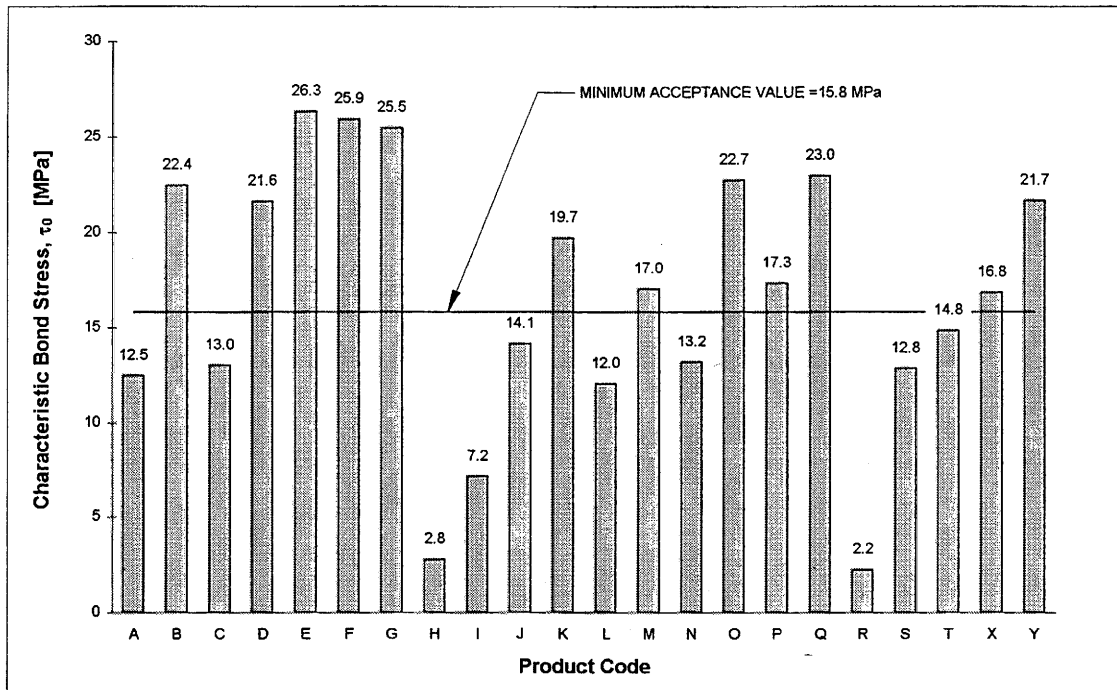

Chart 1 - Summary of Characteristic Bond Strengths (Baseline)

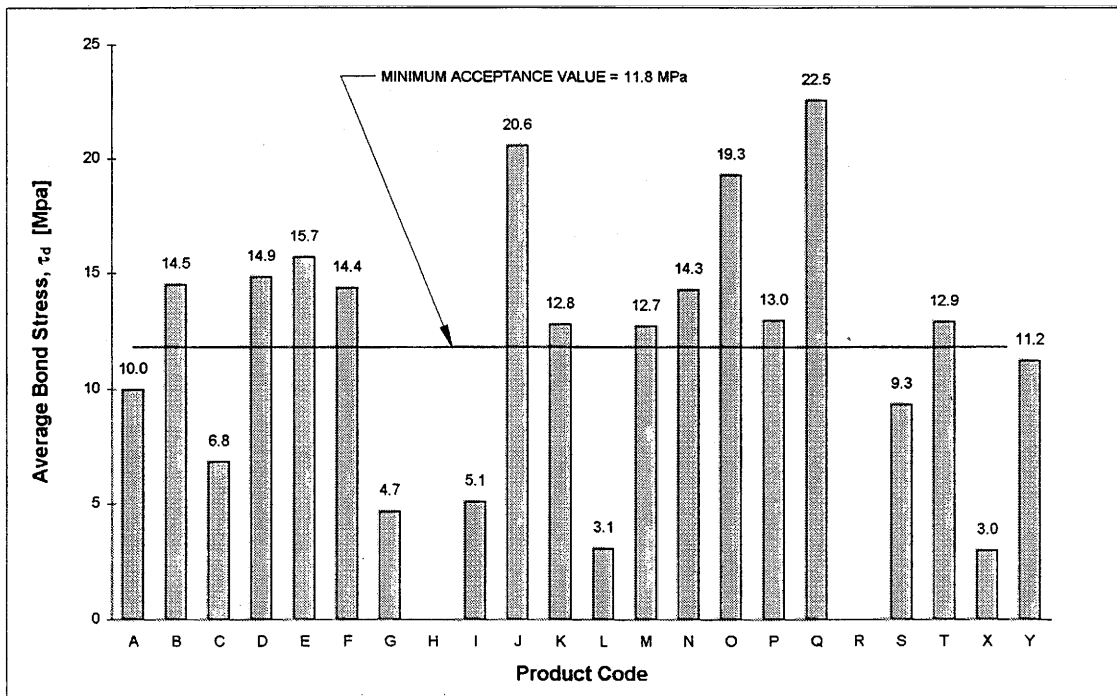

Chart 2 - Summary of Damp-Hole Installation Tests

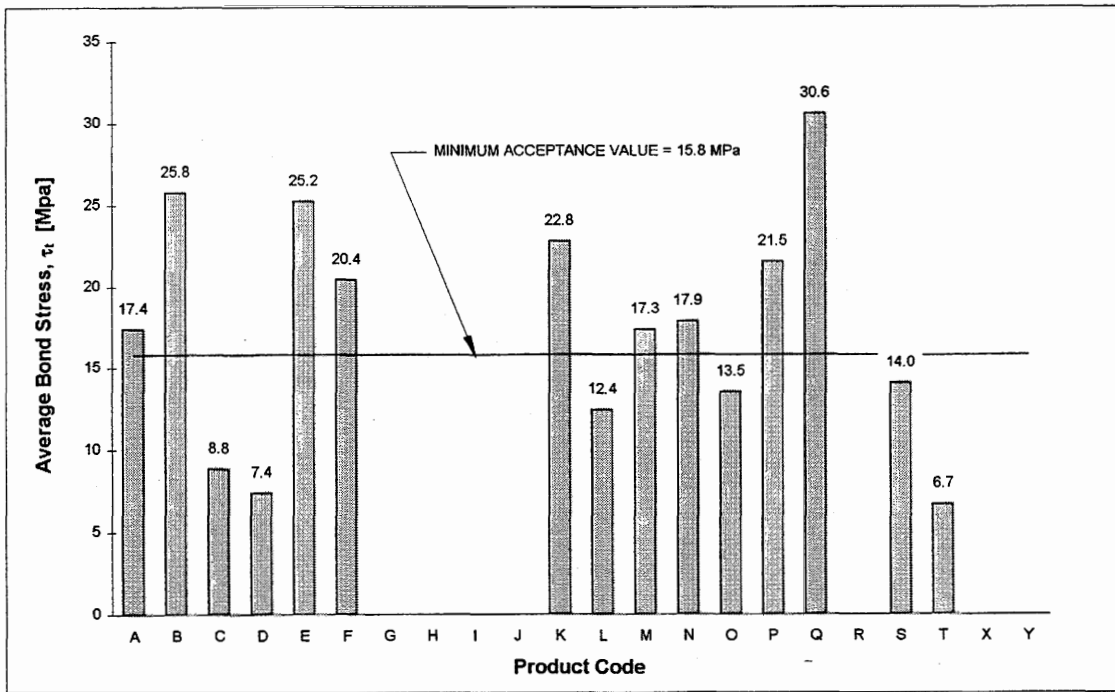

Chart 3 - Summary of Elevated Temperature Tests

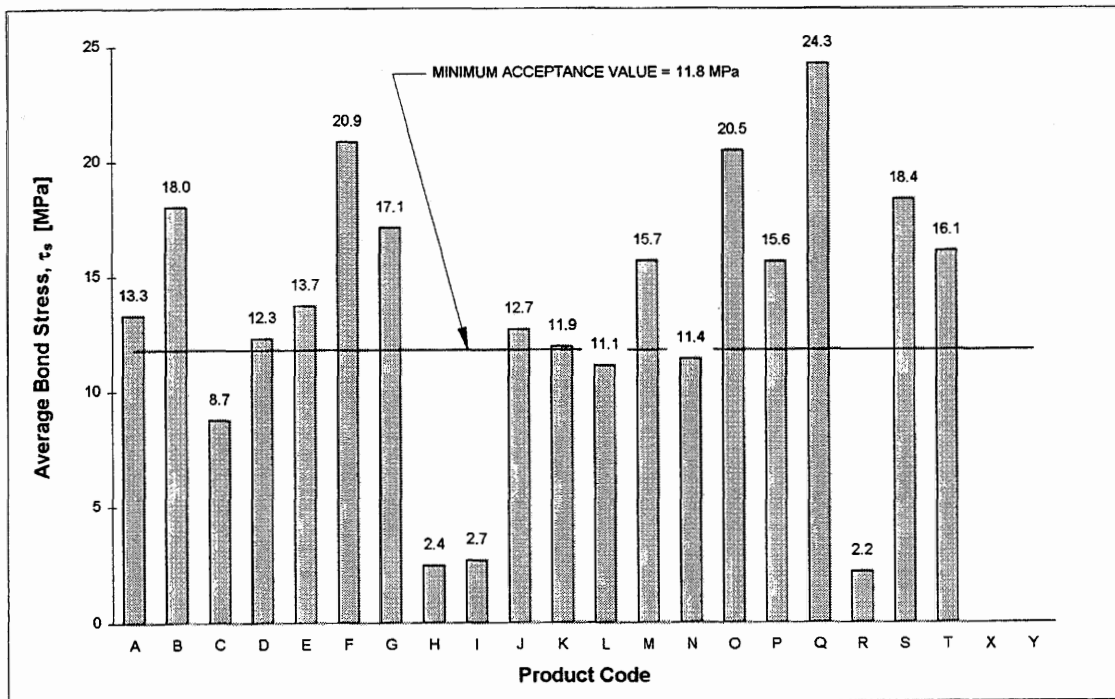

Chart 4 - Summary of Short-Term Cure Tests

For the proposed influence factors, *Damp-Hole Installation* and *Short-Term Cure* must produce at least 75 percent of the minimum baseline bond strength for the “design” adhesive. *Horizontal Orientation*, basically dependent on viscosity, must develop 90 percent, and *Elevated Temperature*, 100 percent of the baseline for the “design” adhesive.

Several additional influence factors were investigated but excluded from the proposed “mandatory” tests. The effects of these “optional” factors were observed to have little or no effect, or were inconsistent with manufacturer’s recommendations.

For the *Uncleaned Hole (Dirty Hole)* test series, a significant reduction in bond strength was observed for most products. Only a few were near, or slightly above their baseline strengths (Chart 5). The benefit of this test series is to demonstrate the importance of properly cleaned holes to avoid dramatic and unpredictable reductions in bond strength. However, this test series was excluded from the qualification methods since uncleaned holes would be inconsistent with the manufacturer’s recommendations.

Another similar argument is evident for *Submerged Installation (Wet Holes)*. While generally not recommended by manufacturers, this type of installation condition would have limited applications. In the case of rain or runoff between drilling and installation, removal of standing water is easily accomplished, resulting in a *Damp-Hole Installation*. Chart 6 summarizes the *Submerged Installation* bond strengths.

The influences of concrete strength and type of coarse aggregate were observed to have little effect on bond strength. *Concrete Strength* and *Concrete Aggregate* are summarized in Charts 7 and 8, respectively.

Charts 9 and 10 summarize the “mandatory” and “optional” influence factors.

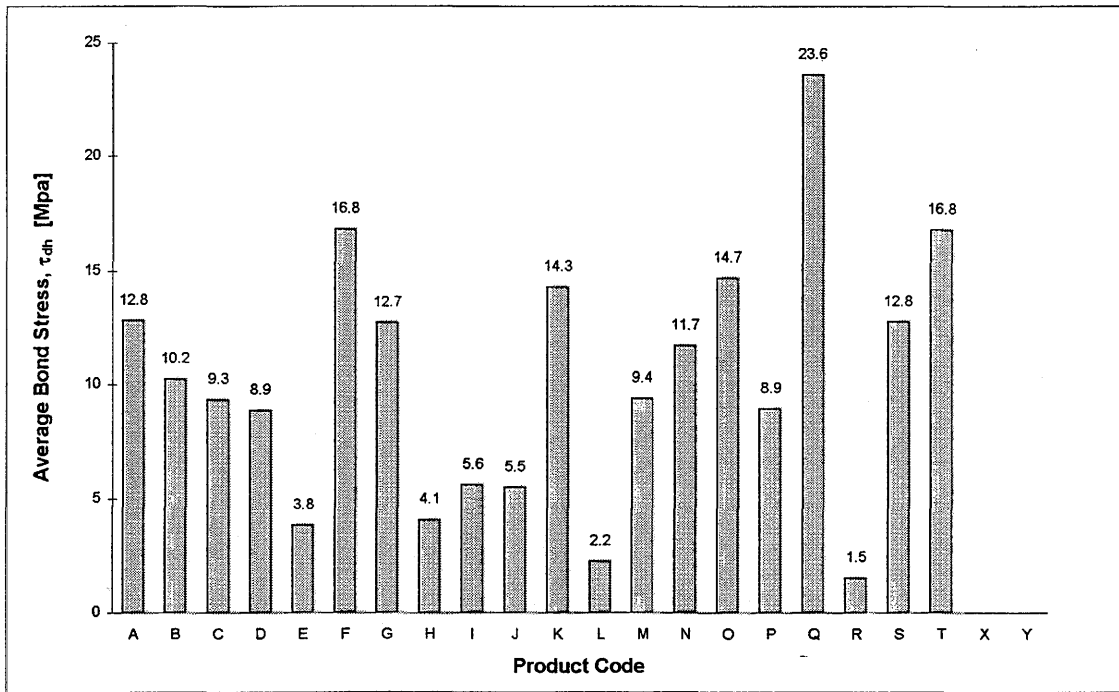

Chart 5 - Summary of Uncleaned Hole Tests

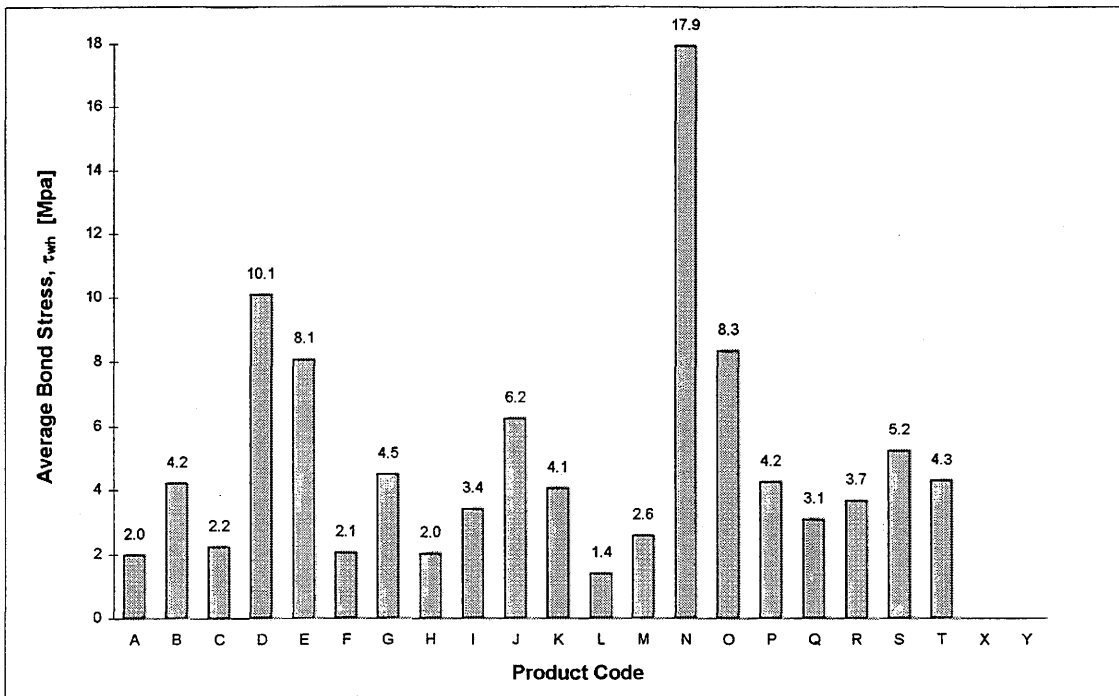

Chart 6 - Summary of Submerged Installation Tests

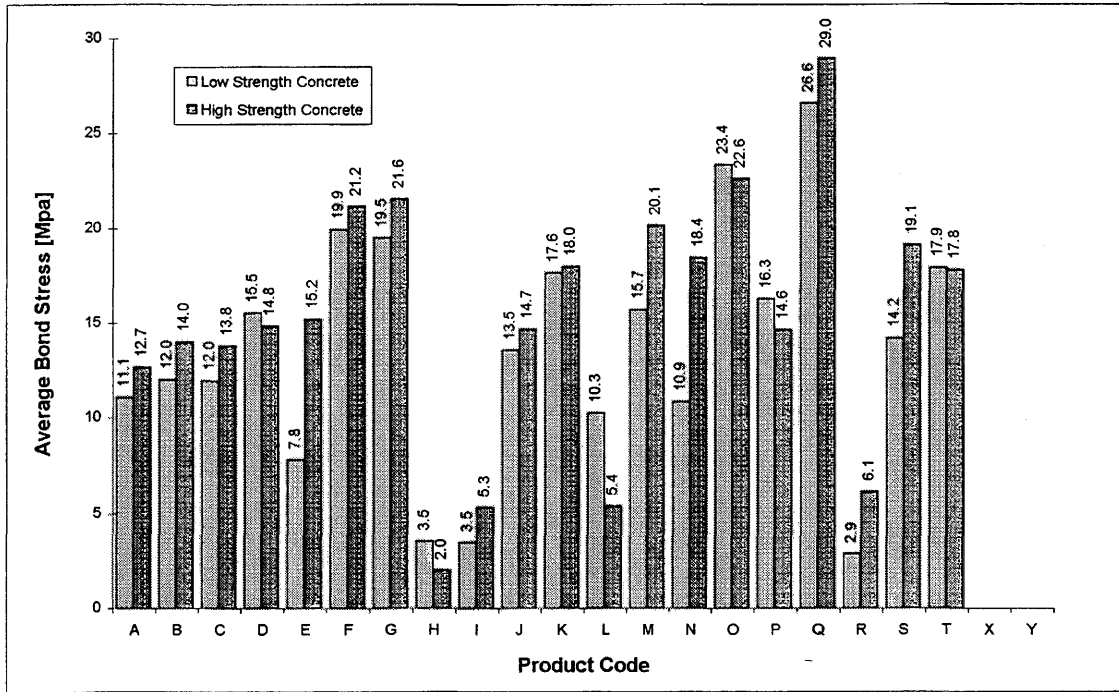

Chart 7 - Summary of Concrete Strength Tests

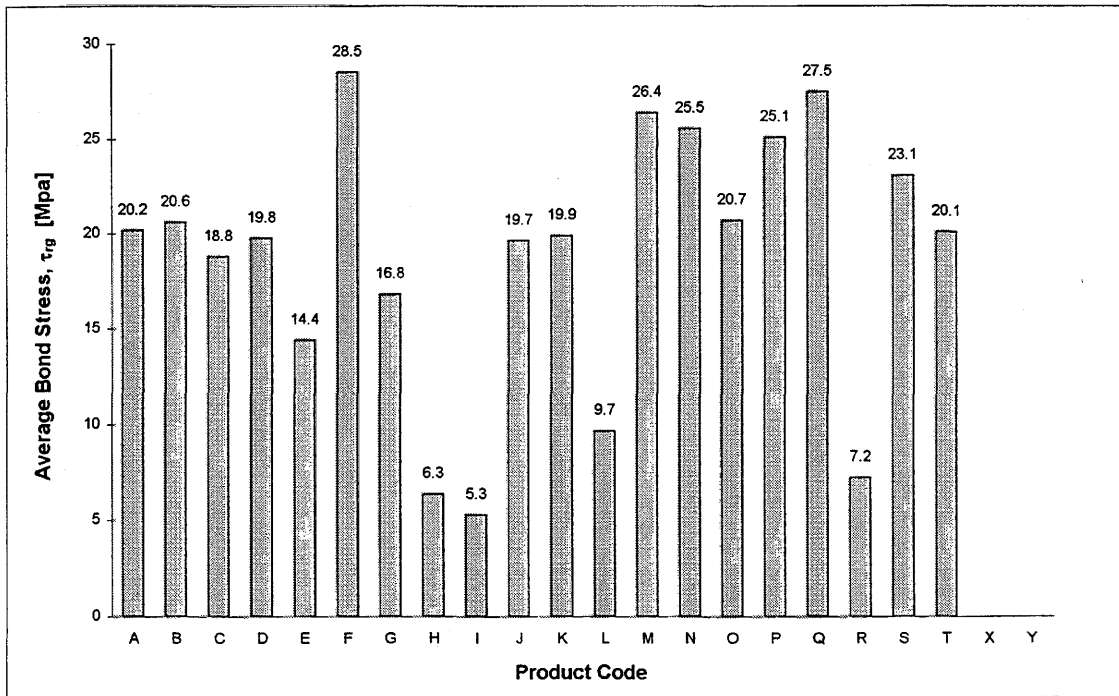

Chart 8 - Summary of Concrete Aggregate (River Gravel) Tests

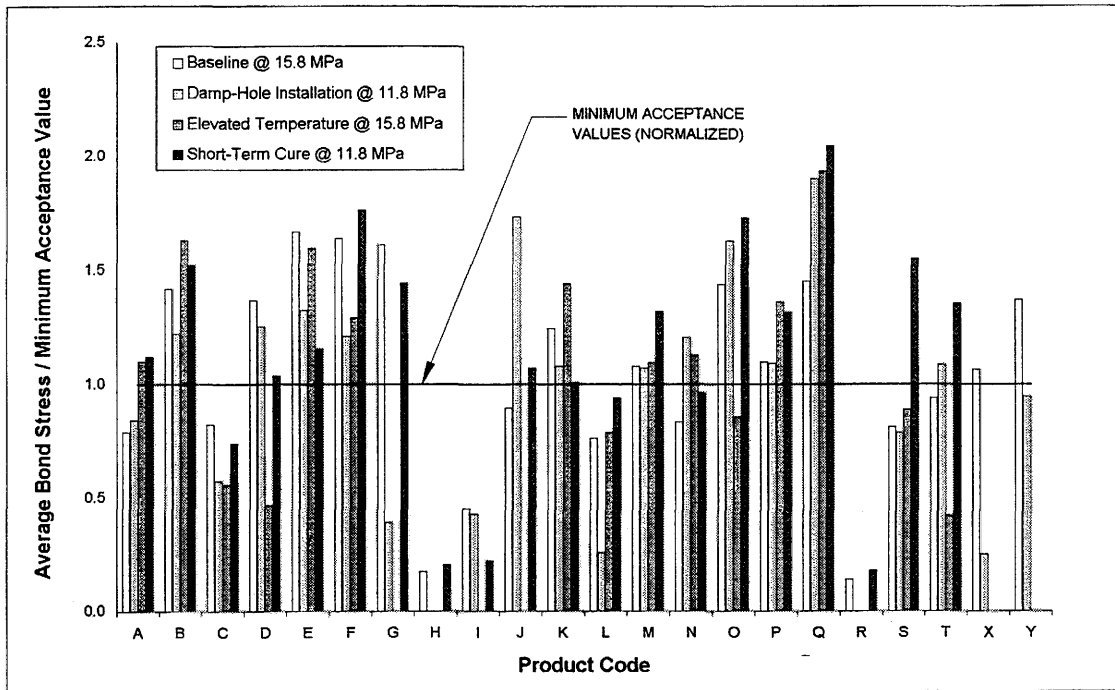

Chart 9 - Partial Summary of Mandatory Influence Factors

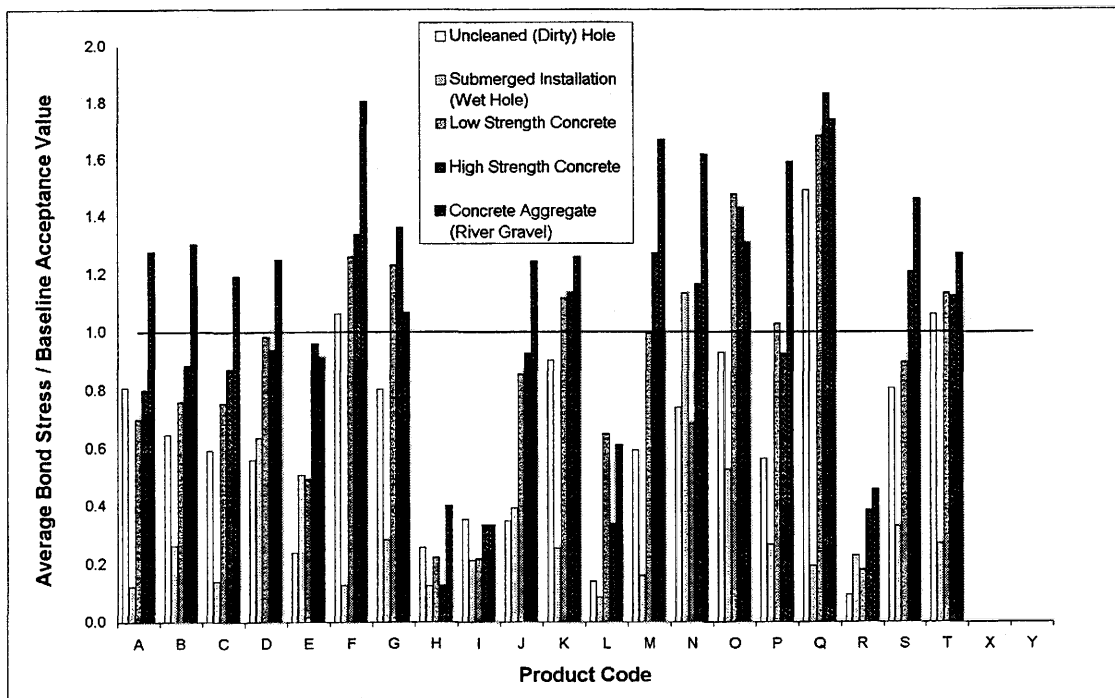

Chart 10 - Summary of Optional Influence Factors

For design purposes, a nominal bond strength is determined from the mean value and coefficient of variation of an *Unconfined Tension* test series. By using the expression given in Appendix C, the nominal bond strength,  $\tau'$ , represents a one-sided 95% tolerance limit with a 75% confidence for the appropriate sample size. Simply, a 75% confidence that 95% of the anchors will develop a nominal bond strength greater than or equal to  $\tau'$ .

### 6.3 DISCUSSION OF INDIVIDUAL TEST SERIES

#### 6.3.1 ADDITIONAL BASELINE TESTS AND RETESTS

Several baseline tests and retests were performed during this subsequent testing phase. Two prototype formulations (X and Y) that were not tested in the initial phase of the program were used to investigate *Horizontal Orientation*. These products were also included in the *Damp-Hole Installation* series.

Also, two commercially available products (B and D) used to investigate the nominal bond strength (*Unconfined Tension*) were retested in the same batch of concrete test members to reduce potential confounding factors. A third product (E) which required a special diameter hole was also retested.

#### 6.3.2 UNCONFINED TENSION

The two products tested for nominal bond strength (*Unconfined Tension*) both exhibited somewhat lower failure loads than for their respective baselines (*Confined Tension*). In general, the coefficients of variation for both products in this series were less than the respective baselines.

#### 6.3.3 "MANDATORY" INFLUENCE FACTORS

##### 6.3.3.1 DAMP-HOLE INSTALLATION

For the 20 products tested, the average strength was about 70 percent that of the corresponding baseline (*Confined Tension*). Only two products, J and N, showed an increase in bond strength. In addition to reduced bond strength, the coefficients of variation were generally larger.

#### 6.3.3.2 ELEVATED TEMPERATURE

For the 15 products tested, the average strength was about 97 percent that of the corresponding baseline. Although most products experienced slight increases, several were significantly less. Focus on the four products subjected to the *Long-Term Load (Creep)* test reveals the two that failed early, D and O, showed great reductions in strength while the two other products, L and N, showed increases. Product L, having one late failure (450 hours) and slightly larger displacements than N, experienced only a modest increase in *Elevated Temperature* over the baseline. Product N, having the smallest displacements due to creep, also had the largest ratio of *Elevated Temperature to Baseline*, about 136 percent.

Although the number of tests in this program were limited, the *Elevated Temperature-to-Confined Tension* ratio appears to be a potential indicator of creep response at an elevated temperature.

#### 6.3.3.3 HORIZONTAL ORIENTATION

Both products tested (prototype formulations) fell far short of their respective baselines or of any reasonable minimum acceptance value. These losses were primarily due to most of the adhesive product flowing from the hole due to relatively low viscosity.

The average retained strength between the two products was only about 23 percent of

the corresponding baselines. Although no tests were performed on other products (all of which exhibited much greater viscosity), the benefit of this test series was to demonstrate the importance of a viscosity sufficient to prevent significant flowout.

#### 6.3.3.4 SHORT-TERM CURE

For the 20 products tested, the average strength was about 85 percent that of the corresponding baseline. Only four products, A, Q, S, and T, showed an increase in bond strength. In addition to reduced bond strength, the coefficients of variation were generally larger.

Product K appeared to perform relatively well in all test series except *Short-Term Cure* was retested in this subsequent testing phase. The retest was about 51 percent larger than the initial test. The coefficients of variation for the initial test and the retest were approximately the same, about 9 and 10 percent, respectively.

#### 6.3.3.5 LONG-TERM LOAD (CREEP)

Of the four products tested, Products D and O failed almost immediately upon application of the test load. The full test load for Product D could not be fully applied before the anchor had displaced more than the allowable maximum. Two specimens of Product O behaved similarly while the third specimen failed within 24 hours.

Products L and N were generally able to resist the test loads, although one specimen (LCT432) failed after approximately 450 hours. For this specimen, the rate of displacement appeared to be slowing, but the magnitude was far greater than the other successful specimen (LCT431). For the remaining specimens, the displacement rates appeared to stabilize after approximately 100 elapsed hours, so the tests were stopped at

1000 hours (about 42 days).

#### 6.3.4 "OPTIONAL" INFLUENCE FACTORS

These influence factors are optional in the sense that the conditions are inconsistent with manufacturer's recommendations or their effects are not relevant to qualification testing. These factors were discussed earlier and include *Uncleaned Hole* (Dirty Hole), *Submerged Installation* (Wet Hole), *Low- and High-Strength Concrete*, and *Concrete Aggregate* (River Gravel).

## 7. CHAPTER SEVEN -- SUMMARY, CONCLUSIONS, AND RECOMMENDATIONS

### 7.1 SUMMARY

The purpose of this research was to develop methods and acceptance criteria for evaluating proposed adhesive products. The data used to arrive at these conclusions and recommendations were gathered over two phases of the test program for a total of 1308 tests (1022 in Phase I, and 286 in Phase II) involving 22 products. Twenty products were commercially-available and two were prototype formulations.

By evaluating product-specific performance characteristics, a "design" adhesive was established with minimum acceptable values for typical installation and service conditions. The specific values achieve a balance between maximum design values and a reasonable number of commercially-available products.

A "fingerprinting" method was identified to establish a unique set of chemical and physical properties for an adhesive product. This fingerprint will serve to verify the composition of a product and to infer the performance characteristics of future production samples.

Appropriate test methods were developed with existing recognized standards and current industry organizations. Portions relevant to FDOT interests were identified with suitable adjustments where necessary.

Preliminary draft documents were developed to assist the FDOT in implementing a qualification method. Standard Specification sections include materials and installation criteria, and a Florida Test Method outlines the specific test methods.

## 7.2 CONCLUSIONS

Based on the results of this research, the following conclusions can be made:

- Product-specific performance characteristics should be determined by recognized test methods.
- A significant reduction in bond strength can occur for bonded anchors installed in a damp hole.
- Relatively low, elevated temperatures can reduce the strength of bonded anchors.
- The response for a short-duration load at an elevated temperature of 110° F may be a potential indicator of creep response.
- A significant reduction in bond strength (due to flowout of adhesive) can occur for horizontal installations of products with a relatively low viscosity.
- A significant fraction of the fully-cured bond strength may not yet be achieved in the initial 24-hours after installation.
- Creep response at an elevated temperature should be determined with a test duration of at least 42 days.
- The 28-day compressive strength of the concrete base material has a negligible effect on the tensile bond strength of adhesive anchors.

### 7.3 RECOMMENDATIONS

Recommendations for topics of further consideration and possible future research include the following:

- The effect of cracked concrete members on the performance of bonded anchors.
- The effect of exposure to extreme temperature (fire).
- The effects of various types and concentrations of chemicals or solvents to which FDOT structures may be exposed.
- The effects of salt-water exposure (marine and brackish).
- The effects of dynamic loading due to wind or traffic and wheel loads.
- The effects due to fatigue from repetitive loadings (traffic, machinery vibration).
- The effects of torsional loads (about the longitudinal axis of the anchor rod).
- The effects due to freezing and thawing.

## REFERENCES

1. Cook, R.A., Bishop, M.C., et al., (1994) "Adhesive-Bonded Anchors: Bond Properties and Effects of In-Service and Installation Conditions," *Structures and Materials Research Report No. 94-2A*, University of Florida, Gainesville, Florida.
2. Collins, D.M., Cook, R.A., Klingner, R.E., and Polyzois, D., (1989) "Load-Deflection Behavior of Cast-in-Place and Retrofit Concrete Anchors Subjected to Static, Fatigue, and Impact Tensile Loads," *Research Report 1126-1*, Center for Transportation Research, University of Texas, Austin, Texas.
3. ICBO Evaluation Service, Inc., "Acceptance Criteria for Adhesive Anchors in Concrete and Masonry Elements (AC58)," International Conference of Building Officials, Whittier, California.
4. Concrete Anchor Manufacturers Association "Procedure for Performing Adhesive Identification (Draft No.5)." Concrete Anchor Manufacturers Association, St. Charles, Missouri, 1996
5. American Society for Testing and Materials, "Standard Test Methods for Strength of Anchors in Concrete and Masonry Elements," *ASTM E 1512 - 93*, 1993 Annual Book of ASTM Standards, American Society for Testing and Materials, Philadelphia, 1993.
6. American Society for Testing and Materials, "Standard Test Methods for Strength of Anchors in Concrete and Masonry Elements," *ASTM E 488 - 96*, 1996 Annual Book of ASTM Standards, American Society for Testing and Materials, Philadelphia, 1996.
7. Cook, R.A., et al., "Behavior and Design of Single Adhesive Anchors under Tensile Load (Draft)," 1996.
8. American Society for Testing and Materials, "Standard Specification for Performance of Anchors in Uncracked Concrete Elements," *ASTM Z5818Z (Draft)* American Society for Testing and Materials, Philadelphia, 1996.
9. American Concrete Institute, "Fastening to Concrete," *CB-30 Chapter 23 (ACI Committee Ballot)*, American Concrete Institute, Detroit, 1996.
10. American Society for Testing and Materials, "Standard Test Method for Density of Adhesives in Fluid Form," *ASTM D 1875 - 95*, 1995 Annual Book of ASTM Standards, American Society for Testing and Materials, Philadelphia, 1995.
11. American Society for Testing and Materials, "Standard Test Method for Gel Time and Peak Exothermic Temperature of Reacting Thermosetting Resins," *ASTM D 2471 - 94*, 1994 Annual Book of ASTM Standards, American Society for Testing and Materials, Philadelphia, 1994.