



## *Florida Department of Transportation*

**JEB BUSH**  
GOVERNOR

605 Suwannee Street  
Tallahassee, FL 32399-0450

**DENVER J. STUTLER, JR.**  
SECRETARY

June 22, 2006

To: William N. Nickas, Robert Robertson  
From: Marc Ansley, Assistant State Structures Design Engineer, Structures Research Center  
Subject: ICP Piles

I have looked over our report and the ICP rebuttal to our report. They have three areas of concern. Below is my response to each of these areas.

1) Lack of Concrete Cover

Our report notes that the cover requirements current with FDOT are not met by the standard ICP piles. The appropriateness of this requirement for spun cast piles is for the Materials Office and others to decide. We would concur that spun casting produces a less permeable concrete.

2) Effect of Spot Weld on prestressing bars

We stand by our results that show the spot welding on occasion impacted the ductility and the fatigue resistance of the prestressing bars. However, not all structural applications may need fatigue resistance or require significant flexural ductility. The Department's report is a valid statement on how this reinforcing differs from the standard prestressing strand we currently use. How critical this is will depend on the intended use.

3) Crack width measurements of more than 0.005 inches during flexural testing

The reported values are what they are. We concur with the rebuttal that this is for one test and may be a statistical aberration. However, only additional testing would allow us to modify our results.

In general, I can not find a major point of conflict between our report and their assertions. When the facts are examined in detail there are few points of disagreement. All structural elements have strengths and weaknesses. It was not that long ago we were using wood piles. Our report focused on the potential problems with these piles assuming that their strengths were obvious and well advertised. I believe our report did solid job of this allowing the Department to make an informed decision as to the appropriateness of using these piles. Except for the crack width issue their rebuttal does not dispute the fundamentals of our report.



Our Ref: HQ/S/831/06

16 May 2006

**FLORIDA DEPARTMENT OF TRANSPORTATION**

Structures Design Office  
605 Suwannee Street, MS33,  
Tallahassee, FL 3299-0480,  
USA.

**Attn: Mr William N. Nickas P. E. (State Structures Design Engineer)**

Dear Sir,

**RE: OFFICIAL REBUTTAL TO REPORT BY FDOT TITLED  
"Structural Performance of ICP PHC Piles" - Posted in FDOT Website**

We refer to the meeting at the above-mentioned office on 18 April 2006.

We have raised our disagreement to the conclusions of the report in the following areas:

- i. Lack of concrete cover,
- ii. Effect of spot-weld on the pre-stress bars,
- iii. Crack width of more than 0.005 inch during static flexural test.

Attached please find our reports explaining our position as regards to the three items above which is summarized below:

- 1) The very dense and compacted concrete resulted from spinning process and lower water-cement ratio makes the pile highly resistance to corrosion. Results of our recent Rapid Chloride Permeability Tests (according to ASTM C1202) on concrete manufactured with Portland cement blended with silica powder (less than 300 coulombs) reaffirmed the excellent durability aspect of the pile.
- 2) Tensile tests conducted by independent laboratory showed that the spot-welded bars are meeting the requirements of JIS G 3137.
- 3) Many bending tests (static flexural tests ) have been conducted on ICP Piles and the results showed that the pile are meeting the required cracking and ultimate bending moments as specified in Japanese and Malaysian standards.



**INDUSTRIAL CONCRETE PRODUCTS BERHAD**  
(32369-W)

裕大



2ND FLOOR, WISMA IJM, JALAN YONG SHOOK LIN, P.O. BOX 191, 46720 PETALING JAYA, SELANGOR, MALAYSIA.  
TEL: 603-79558888 FAX: 603-79581111 <http://www.icpb.com> e-MAIL: [sales@icpb.com](mailto:sales@icpb.com)

Our Ref: HQ/S/831/06

We trust the attached report is in order and hope that you will give consideration to attach it to the F-DOT report.

Thank you.

Yours faithfully,  
**For INDUSTRIAL CONCRETE PRODUCTS BERAHD**

Harry Khor Kiem Teoh  
Chief Operating Officer

FMZ/anne  
(filename: win/d/letter/general)

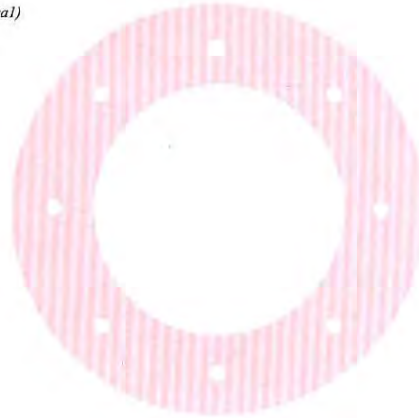

**Rebuttal to FDOT Report on  
ICP PHC Piles**

**By Industrial Concrete Products Berhad  
16 May 2006**

### **Rebuttal to FDOT Report on ICP PHC Piles**

Pre-tensioned Spun Concrete Piles (ICP PHC Piles) have been widely used in Malaysia for the past thirty years. Japan is the pioneer in this industry where it has more than forty years of history behind them. In addition, almost all reinforced concrete piles in Korea, Taiwan and Thailand have been replaced with PHC spun concrete piles. China, being a newcomer since early 1980's, consumed 40 million ton of PHC spun concrete piles in 2003. The piles are part of foundation systems for bridges, all types of buildings, power plants, petrochemical and other heavy industry plants, marine structures, piled embankments and many more. Currently, most consulting engineers are confident in specifying this pile in their designs.

Not surprisingly, due to its excellent durability, high strength and economy in use, ICP PHC Piles have made inroads into several other Asian countries and also to North America. This product was subsequently tested by Florida Department of Transportation (FDOT) and a report written by Mr. Thomas E. Beitelman, was released and can be accessed via internet. The report raised concerns on the usage of Pre-tensioned Spun Concrete Piles in marine environment, i.e. at coastal areas. The reasons given are as follows:-

- i) Lack of concrete cover of the piles
- ii) Effect of spot-weld on pre-stressing bars
- iii) Crack width of more than 0.005 inch (0.127 mm) during static flexural test.

As the producers of ICP PHC Piles and the trademark owner of ICP, we would like to address the concerns raised in the report as follows:-

#### 1) Lack of Concrete Cover of the Piles.

Due to spinning effect used in the process and usage of low water cement ratio of 0.3, the concrete of ICP PHC Piles is very dense and well compacted. Hence, the piles are very durable and have high resistance to corrosion. The piles are highly suitable for projects in coastal areas. These piles were used in many ports and jetties around the world. However, if a project requires thicker concrete cover, bigger sizes of ICP PHC Piles can be chosen. Bigger diameter ICP Piles (dia. 500 mm up to 1200 mm) can provide thicker concrete cover of 50 mm and more.

In addition to the above, Rapid Chloride Permeability (RCP) Tests according to ASTM C1202 have been performed on concrete core samples obtained from ICP Piles to determine its permeability characteristic. The results of the cores taken from piles manufactured using ordinary Portland cement blended with pulverized fuel ash (pfa) were very good. The charges passing were recorded below 1000 coulombs. According to ASTM C1202, these samples are classified as 'very low' chloride permeability. This reaffirms that ICP PHC Piles are suitable for use in the marine environment.

Our recent RCP tests of cores taken from sample piles manufactured using Portland cement blended with *silica sand powder* (30% cement weight replacement) showed even better results with charges passed of less than 300 coulombs. The test results can be viewed in the attached appendix A.

2) Effect of spot weld on pre-stressing bars.

The results of tension tests conducted by FDOT did not indicate any reduction in the yield and ultimate strengths of the bars. The yield and ultimate strength of the spot-welded and un-welded bars are about the same. The average yield strength and ultimate strength of the welded bars are respectively 0.95% higher and 0.19% lower than that of un-welded bars. Basing on the above test results, it can be concluded that the strength of pre-stressing bars are not affected by the spot weld. In fact, the test results also showed that the bars exceeded the requirement specified by JIS G 3137 in terms of tensile and yield strengths regardless whether the bars have been spot-welded or not.

In addition to the above, the supplier of the pre-stressing bars (Durabon Sdn. Bhd) has engaged an independent testing laboratory in Singapore (Professional Testing Services Pte. Ltd) to conduct tension tests on spot-welded pre-stressing bars. The result of the tests also showed that the spot-weld bars are meeting the requirements of Japanese Industrial Standard JIS G3137. In fact one bar out of two tested broke at the un-welded portion. The full report can be viewed in the attached appendix B.

3) Crack width of more than 0.005 inch during static flexural test on diameter 350 mm spun pile.

Over the years, many static flexural tests (bending test) have been conducted and the results showed that ICP PHC Piles have met the required cracking moment and ultimate moment as specified in the Japanese and Malaysian Standards. One of the requirements of these standards is that at Cracking Moment Load the pile should not have crack line of more than 0.05 mm (0.002 inch).

We strongly believed that the appearance of crack of more than 0.005 inch during the flexural static test conducted by F-DOT was due to the pile already damaged prior to the test. Furthermore, one bending test alone is too small a sample to judge the performance of ICP PHC Piles which have been successfully used around the world.

Therefore, we wish to put forward some of the bending test reports by IKRAM QA Services Sdn. Bhd. (A Malaysian Government appointed product certification institution) for reference. The results proved that the piles are meeting the required cracking and ultimate bending moments as specified in the Japanese and Malaysian standards. The reports can be viewed in C1, C2 and C3.

To summarize, ICP PHC Piles are durable, strong, and economical, and with flexibility in supplying various pile sizes and lengths, therefore, the piles are suitable to be used in all types of environments.

**INDUSTRIAL CONCRETE PRODUCTS BHD**

2<sup>nd</sup> Floor Wisma IJM, Jalan Yong Shook Lin,  
P.O Box 191 46720 Petaling Jaya, Selangor, Malaysia  
Tel: 603-79558888 Fax: 603-79581111  
Website: <http://www.icpb.com>  
E-mail: [icpsales@ijm.com](mailto:icpsales@ijm.com)

# **APPENDIX A**

❖ Rapid Chloride Permeability  
Test



# TESTECH SDN. BHD. (207361-H)

## Materials, Structures and Geotechnical Testing

8, Jalan 30B/146, Desa Tasik, Sg. Besi, 57000 Kuala Lumpur, West Malaysia.  
Tel: 03-90593587, 90593589 Fax: 03-90593455

E-mail: inquiry@testech.com.my Website: www.testech.com.my

North Office: 48, Jalan Perusahaan Jelutong 1, 11600 Pulau Pinang, West Malaysia.

Tel: 04-2886551, 2886552 Fax: 04-2886550

E-mail: testech@tm.net.my / perang@testech.com.my



ISO/IEC 17025  
TESTING  
Samm NO. 225

### TEST REPORT

ISSUED BY	: TESTECH SDN BHD	REPORT NO.	: MIS 137/06/R 0403
DATE	: 14-Apr-06	PAGE NO.	: 1 OF 5

1. Test Requested : Rapid Chloride Permeability Test.
  
2. Client : Industrial Concrete Product Berhad  
2nd Floor, Wisma IJM,  
Jalan Yong Shook Lin,  
46050 Petaling Jaya,  
Selangor Darul Ehsan.
  
3. Project : Lab Technical Data
  
4. Date Tested : 13-Apr-06
  
5. Test Method : ASTM C1202-05
  
6. Category of Testing : Laboratory Testing

\* Remarks :  
1) The above test is based solely on sample submitted by client  
2) North Office is NOT SAMM ACCREDITED

*The accuracy of test measurements are probability at 95% confidence level.*

Copyright of this test report is owned by the issuing laboratory and may not be reproduced other than in full except with the prior written approval of the Head of Issuing Laboratory.

REPORT NO. : MIS 137/06/R 0403

PAGE NO. : 2 of 5

Client : Industrial Concrete Product Berhad  
 Project : Lab Technical Data  
 Structure : OPC + Cementation Material                      Lab Ref. : C 164/06

**SUMMARY OF RAPID CHLORIDE PERMEABILITY TEST RESULT**

Concrete Mix Code	Sample Reference	Corrected charge passed (Coulombs)	* Relative chloride permeability
-	1	220.5	Very Low
-	2	135.1	Very Low
-	3	96.9	Negligible
-	4	147.3	Very Low
-	5	126.9	Very Low
-	6	126.2	Very Low

NOTE : \* Refer ASTM C1202-05 - Table 1.

Table 1 : ASTM C1202-05 : Chloride ion penetrability based on charge passed.

Charge passed (coulombs)	Chloride Ion Penetrability
> 4,000	High
>2,000 - 4,000	Moderate
>1,000 - 2,000	Low
100 - 1,000	Very Low
< 100	Negligible

Certified By

Yap Siew Keong  
 Technical Manager



Lab Ref : C 164/06

REPORT NO. : MIS 137/06/R 0403  
PAGE NO. : 3 OF 5

**RAPID CHLORIDE PERMEABILITY TEST RESULTS**

Client : Industrial Concrete Product Berhad  
Project : Lab Technical Data  
Structure : OPC + Cementitious Material  
Tested By : Kyaw Mint  
Test Environmental Condition :- Temperature : 29.1 °C Concrete Mix Code : -  
Relative Humidity (RH) : 82%  
Test Method : ASTM C1202-05

Sample Reference	: 1	Sample Reference	: 2
Diameter of specimen	: 100.0 mm	Diameter of specimen	: 100.0 mm
Length of specimen	: 50.0 mm	Length of specimen	: 50.0 mm
Date of casting	: 30-Mar-06	Date of casting	: 30-Mar-06
Date of testing	: 13-Apr-06	Date of testing	: 13-Apr-06
Density of specimen	: 2470 kg/m <sup>3</sup>	Density of specimen	: 2470 kg/m <sup>3</sup>
Resistor, R	: 1 Ohms	Resistor, R	: 1 Ohms
Initial Temperature of Solution (Sodium Chloride)	: 28.9 °C	Initial Temperature of Solution (Sodium Chloride)	: 28.9 °C
Solution (Sodium Hydroxide)	: 28.9 °C	Solution (Sodium Hydroxide)	: 28.9 °C
Specimen	: 28.9 °C	Specimen	: 28.9 °C
Applied Cell	: 28.9 °C	Applied Cell	: 28.9 °C
Air	: 29.1 °C	Air	: 29.1 °C

Time	Elapse Time (Hours)	Voltage, (millivolt)	Current, I (milliamps)	Temperature, °C			Time	Elapse Time (Hours)	Voltage, (millivolt)	Current, I (milliamps)	Temperature, °C		
				NaCl	NaOH	Air					NaCl	NaOH	Air
11:45 AM	0:00	6.9	6.9	29	29	29	11:45 AM	0:00	5.9	5.9	29	29	29
12:15 PM	0:30	8.5	8.5	29	29	29	12:15 PM	0:30	6.1	6.1	29	29	29
12:45 PM	1:00	10.7	10.7	30	30	30	12:45 PM	1:00	6.3	6.3	29	29	30
1:15 PM	1:30	11.0	11.0	30	30	30	1:15 PM	1:30	6.6	6.6	29	29	30
1:45 PM	2:00	11.2	11.2	30	30	30	1:45 PM	2:00	6.9	6.9	29	29	30
2:15 PM	2:30	11.4	11.4	30	31	30	2:15 PM	2:30	7.0	7.0	29	29	30
2:45 PM	3:00	11.6	11.6	30	31	30	2:45 PM	3:00	7.1	7.1	29	29	30
3:15 PM	3:30	11.8	11.8	30	31	30	3:15 PM	3:30	7.1	7.1	30	30	30
3:45 PM	4:00	12.0	12.0	31	31	30	3:45 PM	4:00	7.2	7.2	30	30	30
4:15 PM	4:30	12.2	12.2	31	31	30	4:15 PM	4:30	7.2	7.2	30	30	30
4:45 PM	5:00	12.4	12.4	31	31	30	4:45 PM	5:00	7.3	7.3	30	30	30
5:15 PM	5:30	12.5	12.5	31	31	29	5:15 PM	5:30	7.3	7.3	30	30	29
5:45 PM	6:00	12.6	12.6	31	31	29	5:45 PM	6:00	7.4	7.4	30	30	29

Sample Reference	1	2
Maximum current recorded	12.6 mA	7.4
Measured Charge passed during the 6 hours period $Q = 900 (I_0 + 2I_{30} + 2I_{60} + \dots + 2I_{330} + I_{360})$ Where Q = charge passed (coulombs), $I_0$ = current (amperes) immediately after voltage is applied. $I_t$ = current (amperes) at t min after voltage is applied	243.1	149.0
Corrected charge passed $Q_s = Q_x \times \left(\frac{3.75}{x}\right)^2$ $Q_s$ = charge passed (coulombs) through a 3.75-in (95mm) diameter specimen. $Q_x$ = charge passed (coulombs) through x in. diameter specimen, and x = diameter (in.) of the non standard specimen	220.5	135.1
Measurement Uncertainty (%)	± 0.277	± 0.284

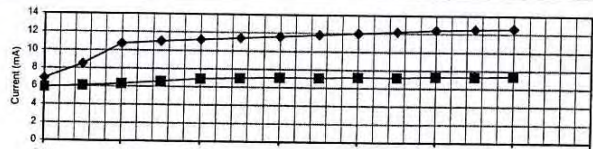

NOTE :  
1. Sodium Chloride, NaCl  
2. Sodium Hydroxide, NaOH

**TESTECH SDN. BHD.**  
Materials, Structures and Geotechnical Testing



Lab Ref. : C 164/06

REPORT NO. : MIS 137/06/R 0403  
PAGE NO. : 4 OF 5

**RAPID CHLORIDE PERMEABILITY TEST RESULTS**

Client : Industrial Concrete Product Berhad  
Project : Lab Technical Data  
Structure : **OPC + Cementitious Material**  
Tested By : Kyaw Mint  
Test Environmental Condition :- Temperature : 29.2 °C Concrete Mix Code : -  
Relative Humidity (RH) : 82%  
Test Method : **ASTM C1202-05**

Sample Reference	3			4		
Diameter of specimen	100.0	mm		100.0	mm	
Length of specimen	50.0	mm		50.0	mm	
Date of casting	30-Mar-06			30-Mar-06		
Date of testing	13-Apr-06			13-Apr-06		
Density of specimen	2450	kg/m <sup>3</sup>		2450	kg/m <sup>3</sup>	
Resistor, R	1	Ohms		1	Ohms	
Initial Temperature of Solution (Sodium Chloride)	28.9	°C		29.0	°C	
Solution (Sodium Hydroxide)	28.9	°C		28.9	°C	
Specimen	28.8	°C		28.8	°C	
Applied Cell	28.9	°C		28.9	°C	
Air	29.1	°C		29.1	°C	

Time	Elapse Time (Hours)	Voltage, (millivolt)	Current, I (milliamperes)	Temperature, °C			Time	Elapse Time (Hours)	Voltage, (millivolt)	Current, I (milliamperes)	Temperature, °C		
				NaCl	NaOH	Air					NaCl	NaOH	Air
11:45 AM	0:00	2.5	2.5	29	29	29	11:45 AM	0:00	5.7	5.7	29	29	29
12:15 PM	0:30	2.8	2.8	29	29	29	12:15 PM	0:30	6.3	6.3	29	29	29
12:45 PM	1:00	3.1	3.1	29	29	30	12:45 PM	1:00	6.5	6.5	29	29	30
1:15 PM	1:30	3.5	3.5	29	29	30	1:15 PM	1:30	6.8	6.8	29	29	30
1:45 PM	2:00	3.9	3.9	30	29	30	1:45 PM	2:00	7.0	7.0	29	29	30
2:15 PM	2:30	4.4	4.4	30	30	30	2:15 PM	2:30	7.3	7.3	30	30	30
2:45 PM	3:00	4.9	4.9	30	30	30	2:45 PM	3:00	7.5	7.5	30	30	30
3:15 PM	3:30	5.3	5.3	30	30	30	3:15 PM	3:30	7.9	7.9	30	30	30
3:45 PM	4:00	5.8	5.8	30	30	30	3:45 PM	4:00	8.2	8.2	30	30	30
4:15 PM	4:30	6.2	6.2	30	30	30	4:15 PM	4:30	8.4	8.4	30	30	30
4:45 PM	5:00	6.7	6.7	30	30	30	4:45 PM	5:00	8.5	8.5	30	30	30
5:15 PM	5:30	7.5	7.5	30	30	29	5:15 PM	5:30	8.6	8.6	30	30	29
5:45 PM	6:00	8.0	8.0	30	30	29	5:45 PM	6:00	8.7	8.7	30	30	29

Sample Reference	3	4	
Maximum current recorded	mA	8.0	8.7
Measured Charge passed during the 6 hours period $Q = 900 (I_0 + 2I_{30} + 2I_{60} + \dots + 2I_{330} + I_{360})$ Where Q = charge passed (coulombs), $I_0$ = current (amperes) immediately after voltage is applied. $I_t$ = current (amperes) at t min after voltage is applied		106.8	162.4
Corrected charge passed $Q_s = Q_x \times \frac{3.75}{x}$ $Q_s$ = charge passed (coulombs) through a 3.75-in (95mm) diameter specimen. $Q_x$ = charge passed (coulombs) through x in. diameter specimen, and $x$ = diameter (in.) of the non standard specimen		96.9	147.3
Measurement Uncertainty (%)	±	0.304	± 0.283

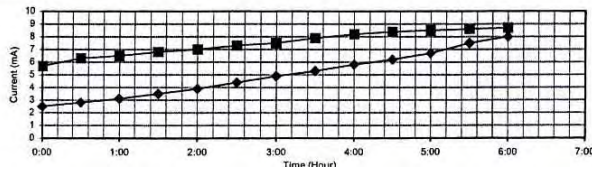

NOTE :  
1. Sodium Chloride, NaCl  
2. Sodium Hydroxide, NaOH

Lab Ref : C 164/06

REPORT NO. : MIS 137/06/R 0403  
PAGE NO. : 5 OF 5

**RAPID CHLORIDE PERMEABILITY TEST RESULTS**

Client : Industrial Concrete Product Berhad  
Project : Lab Technical Data  
Structure : OPC + Cementitious Material  
Tested By : Kyaw Mint  
Test Environmental Condition :- Temperature : 27.6 °C Concrete Mix Code : -  
Relative Humidity (RH) : 86%  
Test Method : ASTM C1202-05

Sample Reference	: 5	Sample Reference	: 6
Diameter of specimen	: 100.0 mm	Diameter of specimen	: 100.0 mm
Length of specimen	: 50.0 mm	Length of specimen	: 50.0 mm
Date of casting	: 30-Mar-06	Date of casting	: 30-Mar-06
Date of testing	: 13-Apr-06	Date of testing	: 13-Apr-06
Density of specimen	: 2450 kg/m <sup>3</sup>	Density of specimen	: 2480 kg/m <sup>3</sup>
Resistor, R	: 1 Ohms	Resistor, R	: 1 Ohms
Initial Temperature of Solution (Sodium Chloride)	: 28.9 °C	Initial Temperature of Solution (Sodium Chloride)	: 28.7 °C
Solution (Sodium Hydroxide)	: 28.8 °C	Solution (Sodium Hydroxide)	: 28.8 °C
Specimen	: 28.9 °C	Specimen	: 28.8 °C
Applied Cell	: 28.8 °C	Applied Cell	: 28.8 °C
Air	: 29.1 °C	Air	: 29.1 °C

Time	Elapse Time (Hours)	Voltage, (millivolt)	Current, I (milliamps)	Temperature, °C			Time	Elapse Time (Hours)	Voltage, (millivolt)	Current, I (milliamps)	Temperature, °C		
				NaCl	NaOH	Air					NaCl	NaOH	Air
11:45 AM	0:00	3.9	3.9	29	29	29	11:45 AM	0:00	3.6	3.6	29	29	29
12:15 PM	0:30	4.4	4.4	29	29	29	12:15 PM	0:30	4.6	4.6	29	29	29
12:45 PM	1:00	4.9	4.9	29	29	30	12:45 PM	1:00	4.9	4.9	29	29	30
1:15 PM	1:30	5.4	5.4	29	29	30	1:15 PM	1:30	5.3	5.3	30	30	30
1:45 PM	2:00	5.9	5.9	29	29	30	1:45 PM	2:00	5.7	5.7	30	30	30
2:15 PM	2:30	6.3	6.3	30	30	30	2:15 PM	2:30	6.1	6.1	30	30	30
2:45 PM	3:00	6.6	6.6	30	30	30	2:45 PM	3:00	6.4	6.4	30	30	30
3:15 PM	3:30	6.8	6.8	30	30	30	3:15 PM	3:30	6.8	6.8	30	30	30
3:45 PM	4:00	7.4	7.4	30	30	30	3:45 PM	4:00	7.3	7.3	30	30	30
4:15 PM	4:30	7.7	7.7	30	30	30	4:15 PM	4:30	7.7	7.7	31	31	30
4:45 PM	5:00	8.0	8.0	31	31	30	4:45 PM	5:00	7.9	7.9	31	31	30
5:15 PM	5:30	8.2	8.2	31	31	29	5:15 PM	5:30	8.4	8.4	31	31	29
5:45 PM	6:00	8.3	8.3	31	31	29	5:45 PM	6:00	8.7	8.7	31	31	29

Sample Reference	5	6
Maximum current recorded	8.3	8.7
Measured Charge passed during the 6 hours period $Q = 900 (I_0 + 2I_{30} + 2I_{60} + \dots + 2I_{330} + I_{360})$ Where Q = charge passed (coulombs), $I_0$ = current (amperes) immediately after voltage is applied. $I_t$ = current (amperes) at t min after voltage is applied	<b>139.9</b>	<b>139.1</b>
Corrected charge passed $Q_s = Q_x \times \left(\frac{3.75}{x}\right)^2$ $Q_s$ = charge passed (coulombs) through a 3.75-in (95mm) diameter specimen. $Q_x$ = charge passed (coulombs) through x in. diameter specimen, and x = diameter (in.) of the non standard specimen	<b>126.9</b>	<b>126.2</b>
Measurement Uncertainty (%)	± 0.288	± 0.288

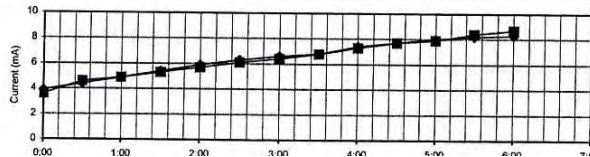

NOTE :  
1. Sodium Chloride, NaCl  
2. Sodium Hydroxide, NaOH

# **APPENDIX B**

- ❖ Report on Tensile Test on Spot-Welded UBON Prestressing Steel



**DURABON SDN BHD** (392693-W)

SALES & SENAI WORKS : LOT 27, JALAN PERINDUSTRIAN 4, KAWASAN PERINDUSTRIAN SENAI,  
FASA II, 81400 SENAI, JOHOR, MALAYSIA.  
TEL NO: 007-6892630/82 FAX NO: 007-6991700 EMAIL: chpang@durabon.com



Ref. No: DSN/0887/06  
Date: 14<sup>th</sup> Jan. 2006

To: Mr. Harry Khor (COO – ICPB)  
Mr. Tan Boon Leng (Senior Sales Manager - ICPB)

Dear Sirs,

**Sub: Mechanical Properties Test Report For UBON Prestressing Steel Bars  
After Spot-Welded Condition**

As per your client's request on the above, please find attached the said reports for your onward submission,

- a. Report A: Mechanical properties of UBON Prestressing steel bar for nominal size 9.0mm **BEFORE** spot-welding (Page 2 of 5)
- b. Report B: Mechanical properties of UBON Prestressing steel bar **AFTER** spot-welding (Page 3 to 5 of 5) Laboratory Test No: PTS/91721.

From the mechanical properties tests carried out on the spot-welded UBON Prestressing Concrete steel bars after caging, the results shown that Yield Stress, Ultimate Tensile Stress and Elongation are meeting the requirements of Japanese Industrial Standard JIS G3137.

Thank you

.....  
C. H. Pang  
General Manager  
Durabon Sdn. Bhd.

.....  
M. Pajar Sarih  
QA Section Head  
Durabon Sdn. Bhd.



Report A: Mechanical properties of UBON Prestressing steel bar for nominal size 9.0mm BEFORE spot-welding.

## DURABON TENSILE TEST

Standard JIS G 3137  
 Date/Time: 01-12-2006

Customer:  
 Operator: ZAIDI

Shape: Rod  
 Diameter: 9.18  
 Gauge Length: 250.00  
 Extensometer GL: 100.00  
 Name: 06-42748  
 Remarks:

Calc.	Yield Load	Yield Stress	Tensile Load	Tensile Stress	Elongation
CP1, CP2	0.200				
CP Unit	[%]				
Pass-Fail	---	---	---	1420, 1560.	5.0, 15.0
Unit	[kN]	[N/mm2]	[kN]	[N/mm2]	[%]
06-42748	92.3	1442.	96.2	1502.	9.0

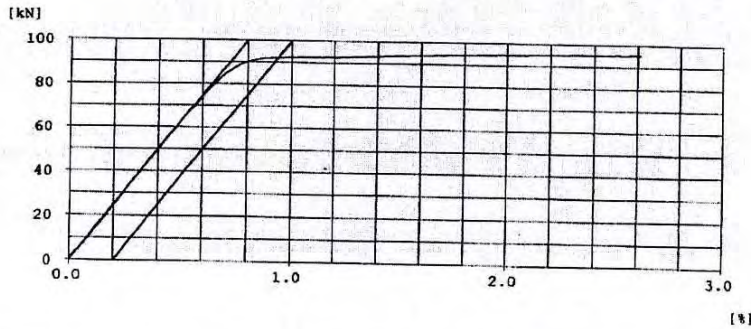



# DURABON SDN BHD (392693-W)

SALES & SENAI WORKS : LOT 27, JALAN PERINDUSTRIAN 4, KAWASAN PERINDUSTRIAN SENAI, FASA II, 81400 SENAI, JOHOR, MALAYSIA.  
TEL NO: 607-5992608/8082 FAX NO: 607-5991700 EMAIL: chpang@durabon.com



Report B: Mechanical properties of UBON Prestressing steel bar for nominal size 9.0mm AFTER spot-welding.



## Professional Testing Services Pte Ltd

32 Kian Teck Road, Singapore 628779.  
Tel: 6778 1271 (6 Lines) Fax: 6779 3621 Email: ptspl@singnet.com.sg  
Web Site: http://www.ptspl.com  
Co. Reg No.: 00774/1985-K

### MECHANICAL TEST REPORT

Laboratory Test No : PTS / 91721-1 / 05 Date Tested : 03 December 2005  
Customer : Durabon Sdn.Bhd.  
Lot 27, Jln Perindustrian 4  
Kaw Perindustrian Senai, Fasa II  
Malaysia

P O / Order No : -- Total Page : 3 Pages  
Reference Code : JIS G 3137 : 1994 Your Ref : --  
Date of Receipt of Test Items : 02 December 2005  
Subject (as received) :

Two UBON PC steel bar with spot-weld mark test samples, Marked: Size: UB9.0mm, Spot Weld Interval: 100mm, Material : JIS G 3137 Grade D Class 1 (SBPDL 1275/1420), for Tensile Test.

Tensile Test : Longitudinal Specimen, Test Temperature : +23°C to +30°C  
Test Method : JIS Z 2241

Specimen Number	Spot Weld Interval : 100mm, UB9.0mm (Sample 1)	Spot Weld Interval : 100mm, UB9.0mm (Sample 2)	Requirements
Measured Diameter (mm)	9.13	9.10	--
Measured Thickness (mm)	--	--	--
Measured Width (mm)	--	--	--
Nominal Cross Sectional Area (mm <sup>2</sup> )	64.00	64.00	--
Yield Load (kN)	95.74	93.25	--
Yield Stress * (N/mm <sup>2</sup> )	1496	1457	1275 min.
Ultimate Tensile Load (kN)	97.15	95.17	--
Ultimate Tensile Stress (N/mm <sup>2</sup> )	1518	1487	1420 min.
Gauge Length (mm)	72	72	--
Elongation (%)	9	6	5 min.
Reduction of Area (%)	--	--	--

Test Conducted By : Kelvin Por  
Test Witnessed By : --  
Remarks : \*0.2% Proof Stress; Extensometer GL : 100mm

Approved Signatory

C.K. Tan, B.Sc. M.Sc.  
Laboratory Manager



**DURABON SDN BHD** (392893-W)  
SALES & SENAI WORKS - LOT 27, JALAN PERINDUSTRIAN 4, KAWASAN PERINDUSTRIAN SENAI,  
FASA II, 81400 SENAI, JOHOR, MALAYSIA.  
TEL NO: 607-5992898/9182 FAX NO: 607-5991700 EMAIL: [chipang@durabon.com](mailto:chipang@durabon.com)



## Professional Testing Services Pte Ltd

32 Kian Teck Road, Singapore 628779.  
Tel: 6778 1271 ( 5 Lines) Fax: 6779 3621 Email: [ptspl@singnet.com.sg](mailto:ptspl@singnet.com.sg)  
Web Site: <http://www.ptspl.com>  
Co. Reg No.: 00774/1985-K

### TEST REPORT

Laboratory Test No : PTS / 91721-2 / 05

Date Tested : 03 December 2005

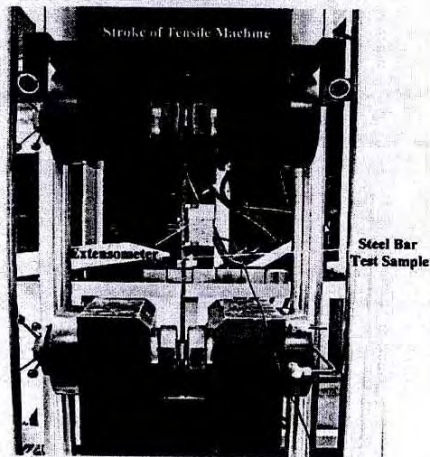

Photograph of Tensile Test Setup

Approved Signatory

  
C. K. Tee, B.Sc. M.Sc.  
Laboratory Manager

Form No : PHOTO21102000

This report shall not be reproduced except in full, without the written approval of the laboratory.



**DURABON SDN BHD** (392693-W)  
 SALES & SENAI WORKS : LOT 27, JALAN PERINDUSTRIAN 4, KAWASAN PERINDUSTRIAN SENAI,  
 FASA II, #1400 SENAI, JOHOR, MALAYSIA.  
 TEL NO: 607-592580/81/82 FAX NO: 607-5991700 EMAIL: chpeng@durabon.com



**Professional Testing Services Pte Ltd**

32 Kian Teck Road, Singapore 628779.  
 Tel: 6778 1271 ( 5 Lines) Fax: 6779 3621 Email: ptspl@singnet.com.sg  
 Web Site: http://www.ptspl.com  
 Co., Reg No.: 00774/1985-K

**TEST REPORT**

Laboratory Test No : PTS / 91721-3 / 05

Date Tested : 03 December 2005

**Before Testing**



Spot Weld Interval: 100mm



UB9.0mm Sample 1 & 2

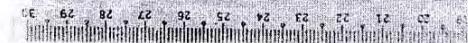

Macro-photograph of Sample Marked: Spot Weld Interval: 100mm, UB9.0mm (Sample 1 & 2)

**After Breaking**



Spot Weld Interval: 100mm



UB9.0mm Sample 1 & 2



Macro-photograph of Sample Marked: Spot Weld Interval: 100mm, UB9.0mm (Sample 1 & 2)

Approved Signatory

*[Signature]*  
 C. K. Teo, B.Sc. M.Sc.  
 Laboratory Manager

Form No : PHOT021102000  
 This report shall not be reproduced except in full, without the written approval of the laboratory.

# **APPENDIX C1**

- 1) Bending Test Report  
No.SPB/42/2000 dated 27/11/2000
  - i) Dia.350mm X 12m
  - ii) Dia.400mm X 12m



**IKRAM QA SERVICES Sdn Bhd**  
(A member of Kumpulan Ikram Sdn Bhd)

Taman Ilmu Ikram (Ikram Park)  
Jalan Serdang, 43000 Kajang,  
Selangor, Malaysia.  
Tel: (603) 8737 3320  
Fax: (603) 8736 7254  
e-mail: IQCI@kisbedu.com.my  
http://www.kisb.com.my

No. Laporan	SPB/42/2000	Nombor Ujian	SPB/42/A1611/N49/00
Laporan ini mengandungi	14 Muka Surat		Muka Surat 1/14
Pemohon	Industrial Concrete Products Bhd., Tingkat 2, Wisma IJM, Jalan Yong Shook Lin, P. O. Box 191, 46720 Petaling Jaya. (u/p: Ir. Yue Kam Fatt)		
Tajuk Kerja Atau Projek	Type Test For Precast Pretensioned Spun Concrete Piles (Industrial Concrete Products Bhd., Ipoh)		
Ruj. IQCI	(2)KISB/IQCI/B04/16.55		
Tarikh Lawatan	07/11/2000		
Tarikh Laporan	27/11/2000		
Keterangan Sampel:	Precast Pretensioned Spun Concrete Piles Sample 1 & 2 : Ø 300mm x 6m + 6m [Joints welded] - Bending strength test - 2 nos. Sample 3 : Ø 350mm x 12m - Dimension & Bending strength test - 1 no. Sample 4 : Ø 400mm x 12m - Dimension & Bending strength test - 1 no.		
Penandaan Sampel	Sample 1 - ICP 30 A 800 6E 18.10.00 026H1 Sample 2 - ICP 30 A 800 6E 18.10.00 028H1 Sample 3 - ICP 35 A 800 12E 30.09.00 001H1 Sample 4 - ICP 40 A 800 12E 01.09.00 027H1		
Cara Ujian	Piawaian MS 1314:Part 1:1993		
Keterangan Ujian	Cl. 6, 7, 10, 11 & 13 [Dimension, Workmanship and Finish & Markings] & Cl. 9 Bending Strength Test.		

Sekian, terima kasih.

Yang benar,  
IKRAM QA Services Sdn. Bhd.

(HJ. YAHYA BIN HJ. ARIFFIN)  
PENGURUS BESAR  
INSTITUT KUALITI & PERSIJILAN IKRAM

Laporan ujian ini HANYA meliputi sampel-sampel terpilih yang diuji di kilang / Institut Kualiti & Pensijilan Ikram sahaja. Laporan ujian ini hendaklah digunakan dalam bentuk penuh dan TIDAK BOLEH digunakan untuk sebarang bentuk publisiti tanpa mendapat kebenaran bertulis daripada Pihak IKRAM QA Services Sdn. Bhd.

**Research . Education . Services . Training**  
**REST** Assured of Excellence

<b>LAPORAN UJIAN</b>	
<b>Tarikh Ujian</b>	: 07/11/2000 <span style="float: right;"><b>Muka Surat:</b> 8 / 14</span>
<b>Tempat Ujian</b>	: Industrial Concrete Products Bhd., Ipoh.
<b>Pegawai Yang Menguji</b>	: Azman Idris & Tee Eng Kheng
<p>Laporan ujian ini <b>HANYA</b> meliputi sampel-sampel terpilih yang diuji di kilang dan <b>BUKAN</b> merupakan perakuan penentuan kualiti. Ianya juga <b>BUKAN</b> sijil kelulusan.  Laporan ujian ini hendaklah digunakan dalam bentuk penuh dan <b>TIDAK BOLEH</b> digunakan untuk sebarang bentuk publisiti tanpa mendapat kebenaran bertulis daripada pihak IKRAM QA Services Sdn. Bhd.</p>	

**Keterangan Sampel** : Precast Pretensioned Spun Concrete Piles - Sample 3 (Ø 350mm x 12m)

**Cara Pengujian** : Piawaian MS 1314:Part 1:1993 - Clause 9 Bending Strength

**Tajuk Kerja** : TypeTest For Precast Pretensioned Spun Concrete Piles **Nombor Ujian** : SPB/42/A1611/N49/00

1.	Calculated Cracking Bending Moment (Mcc)	4.68 Ton-m
		46.8 kN-m
2.	Calculated Load To Achieve Mcc (Pcc)	26.5 kN
		2.65 Tonne
3.	Calculated Load To Achieve 1.5 times Mcc	4.16 Tonne
4.	Rate of Loading	0.07 N/mm <sup>2</sup> /sec.
		10.00 psi/sec.
5.	Ram Area	50.265 in <sup>2</sup>
		32428.97 mm <sup>2</sup>

No.	Loading	Observation
1.	Loading to Pcc : 2.65 tonne Gauge reading : 120 psi	Gauge reading at Pcc : 120 psi Remarks : No crack was observed.
2.	Further loading after Pcc and observed the first crack	Load at first cracking : 170 psi Crack width : < 0.05mm
3.	Increase load to achieve 1.5 times Mcc (4.16 tonne) Gauge reading : 190 psi	Crack width : < 0.05mm Condition of pile : pile was intact.

**Remarks:** The above 'Bending Test' was complied, please refer to test results on page 9 of 14.

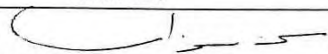
<b>Disediakan Oleh</b>	<b>Disemak Oleh</b>
Tee Eng Kheng	Azman Idris
	

LAPORAN UJIAN	
<b>Tarikh Ujian</b>	: 07/11/2000 <span style="float: right;">Muka Surat: 9 / 14</span>
<b>Tempat Ujian</b>	: Industrial Concrete Products Bhd., Ipoh.
<b>Pegawai Yang Menguji</b>	: Azman Idris & Tee Eng Kheng
<p>Laporan ujian ini <b>HANYA</b> meliputi sampel-sampel terpilih yang diuji di kilang dan <b>BUKAN</b> merupakan perakuan penentuan kualiti. Ianya juga <b>BUKAN</b> sijil kelulusan.  Laporan ujian ini hendaklah digunakan dalam bentuk penuh dan <b>TIDAK BOLEH</b> digunakan untuk sebarang bentuk publisiti tanpa mendapat kebenaran bertulis daripada Pihak IKRAM QA Services Sdn. Bhd.</p>	

### Test Results

Nombor Ujian : SPB/42/A1611/N49/00

Time (sec.)	Load (psi) [Gauge reading]	Remarks
0	0	No crack was observed before initial load was applied.
5	50	
12	120	Pcc at gauge reading = 120 psi [2.65 tonne] No crack was observed.
17	170	First cracking load at gauge reading : 170 psi Five (5) hairline cracks < 0.05mm were observed & checked with feeler gauge.
19	190	1.5 x Mcc at gauge reading = 190 psi (4.16 tonne) The above cracks width < 0.05mm were remained intact.
<p><b>Remarks :</b> The above 'Bending Strength Test' was complied.  Pressure Gauge (Badotherm, Holland), 1 div. = 10 psi, Max. capacity: 600 psi  Certificate No.: P0290343  Calibrated by : Pyrometro Services (M) Sdn. Bhd.  Date due : 03.04.2001</p>		

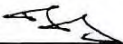
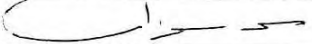
Disediakan Oleh	Disemak Oleh
Tee Eng Kheng	Azman Idris
	

**LAPORAN UJIAN**

**Tarikh Ujian** : 07/11/2000 **Muka Surat:** 13/14  
**Tempat Ujian** : Industrial Concrete Products Bhd., Ipoh.  
**Pegawai Yang Menguji** : Azman Idris & Tee Eng Kheng

Laporan ujian ini **HANYA** meliputi sampel-sampel terpilih yang diuji di kilang dan **BUKAN** merupakan perakuan penentuan kualiti. Ianya juga **BUKAN** sijil kelulusan.  
 Laporan ujian ini hendaklah digunakan dalam bentuk penuh dan **TIDAK BOLEH** digunakan untuk sebarang bentuk publisiti tanpa mendapat kebenaran bertulis daripada pihak IKRAM QA Services Sdn. Bhd.

**Keterangan Sampel** : Precast Pretensioned Spun Concrete Piles - Sample 4 (Ø 400mm x 12m)  
**Cara Pengujian** : Piawaian MS 1314:Part 1:1993 - Clause 9 Bending Strength  
**Tajuk Kerja** : TypeTest For Precast Pretensioned Spun Concrete Piles Nombor Ujian : SPB/42/A1611/N49/00

1.	Calculated Cracking Bending Moment (Mcc)	7.05 Ton-m
		70.5 kN-m
2.	Calculated Load To Achieve Mcc (Pcc)	40.6 kN
		4.06 Tonne
3.	Calculated Load To Achieve 1.5 times Mcc	6.34 Tonne
4.	Rate of Loading	0.07 N/mm <sup>2</sup> /sec.
		10.00 psi/sec.
5.	Ram Area	50.265 in <sup>2</sup>
		32428.97 mm <sup>2</sup>

No.	Loading	Observation
1.	Loading to Pcc : 4.06 tonne Gauge reading : 180 psi	Gauge reading at Pcc : 180 psi Remarks : No crack was observed.
2.	Further loading after Pcc and observed the first crack	Load at first cracking : 240 psi Crack width : < 0.05mm (i.e. 1 nos.)
3.	Increase load to achieve 1.5 times Mcc (6.34 tonne) Gauge reading : 280 psi	Crack width : < 0.05mm (Total : 3 nos.) Condition of pile : pile was intact.

**Remarks:** The above 'Bending Test' was complied, please refer to test results on page 14 of 14.

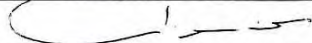
<b>Disediakan Oleh</b>	<b>Disemak Oleh</b>
Tee Eng Kheng	Azman Idris
	

LAPORAN UJIAN	
<b>Tarikh Ujian</b> :	07/11/2000 <span style="float: right;"><b>Muka Surat:</b> 14/14</span>
<b>Tempat Ujian</b> :	Industrial Concrete Products Bhd., Ipoh.
<b>Pegawai Yang Menguji</b> :	Azman Idris & Tee Eng Kheng
<p>Laporan ujian ini <b>HANYA</b> meliputi sampel-sampel terpilih yang diuji di kilang dan <b>BUKAN</b> merupakan perakuan penentuan kualiti. Ianya juga <b>BUKAN</b> sijil kelulusan.</p> <p>Laporan ujian ini hendaklah digunakan dalam bentuk penuh dan <b>TIDAK BOLEH</b> digunakan untuk sebarang bentuk publisiti tanpa mendapat kebenaran bertulis daripada Pihak IKRAM QA Services Sdn. Bhd.</p>	

### Test Results

Nombor Ujian : SPB/42/A1611/N49/00

Time (sec.)	Load (psi) [Gauge reading]	Remarks
0	0	No crack was observed before initial load was applied.
5	50	No crack was observed.
10	100	- Ditto -
18	180	Pcc at gauge reading = 180 psi [4.06 tonne] No crack was observed.
24	240	First cracking load at gauge reading = 240psi A single hairline crack < 0.05mm was observed & checked with feeler gauge.
25	250	Another hairline crack < 0.05mm was observed.
28	280	<b>1.5 x Mcc</b> at gauge reading = 280 psi (6.34 tonne) Another hairline crack < 0.05mm was observed. However, all cracks width < 0.05mm mentioned above were remained intact.
<p><b>Remarks :</b> The above 'Bending Strength Test' was complied.            Pressure Gauge (Badotherm, Holland), 1 div. = 10 psi, Max. capacity: 600 psi            Certificate No.: P0290343            Calibrated by : Pyrometro Services (M) Sdn. Bhd.            Date due : 03.04.2001</p>		

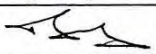
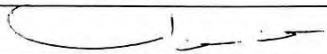
Disediakan Oleh	Disemak Oleh
Tee Eng Kheng	Azman Idris
	

## **APPENDIX C2**

- 2) Bending Test Report  
No.SPB/42/2003 dated 19/9/03
  - i) Dia.350mm X 12m

**IKRAM QA SERVICES Sdn Bhd** (479565 A)

Blok 5, Tingkat 1, Taman Ilmu Ikram (Ikram Park), Jalan Serdang-Kajang, 43000 Kajang,  
Selangor Darul Ehsan, Malaysia.  
Tel : (603) 8737 3320 Fax : (603) 8736 7254  
e-mail : IQCI@kisbedu.com.my  
http : //www.ikram.com.my



(Ahli Kumpulan IKRAM Sdn Bhd)

<b>No. Laporan</b>	SPB/42/2003	<b>Nombor Ujian</b>	SPB/42/R5/A1620/03
<b>Laporan ini mengandungi</b>	6 Muka Surat		Muka Surat 1/6
<b>Pemohon</b>	Industrial Concrete Products Bhd., Lot 22936, Batu 6, Jalan Kebun, Kg. Jawa Mukim Klang, 42450 Klang. (u/p: Ir. Yue Kam Fatt)		
<b>Tajuk Kerja Atau Projek</b>	Type Test For Precast Pretensioned Spun Concrete Piles (Industrial Concrete Products Bhd.)		
<b>Ruj. IQCI</b>	(16)KISB/IQCI/B04/16.08		
<b>Tarikh Lawatan</b>	18/9/03		
<b>Tarikh Laporan</b>	19/9/03		

<b>Sampel</b>	<b>Keterangan Sampel</b>	<b>Penglabelan Sampel</b>
Sample 1	Type Tests for Precast Pretensioned Spun Concrete Piles  Ø 350mm x 12m - Dimension & bending strength tests	PS 1
<b>Cara Ujian</b>	Spesifikasi ILP-1-91	
<b>Keterangan Ujian</b>	Cl. 6, 7, 10, 11 & 13 [Dimension, Workmanship and Finish & Markings] & Cl. 9 Bending Strength Test.	

Sekian, terima kasih.

Yang benar,

IKRAM QA Services Sdn. Bhd.

(HJ YAHYA HJ. ARIFFIN)  
PENGARAH PERSIJILAN  
INSTITUT KUALITI & PERSIJILAN IKRAM

Laporan ujian ini **HANYA** meliputi sampel-sampel terpilih yang diuji di kilang dan **BUKAN** merupakan sijil kelulusan atau perakuan penentuan kualiti.  
Laporan ujian ini hendaklah digunakan dalam bentuk penuh dan **TIDAK BOLEH** digunakan untuk sebarang bentuk publisiti tanpa mendapat kebenaran bertulis daripada IKRAM QA Services Sdn. Bhd.

LAPORAN UJIAN	
<b>Tarikh Ujian</b> : 18/9/03	<b>Muka Surat:</b> 5 / 6
<b>Tempat Ujian</b> : Industrial Concrete Products Bhd.	
<b>Pegawai Yang Menguji</b> : Azman Idris & Tee Eng Kheng	
Laporan ujian ini <b>HANYA</b> meliputi sampel-sampel terpilih yang diuji di kilang dan <b>BUKAN</b> merupakan sijil kelulusan atau perakuan penentuan kualiti. Laporan ujian ini hendaklah digunakan dalam bentuk penuh dan <b>TIDAK BOLEH</b> digunakan untuk sebarang bentuk publisiti tanpa mendapat kebenaran bertulis daripada pihak IKRAM QA Services Sdn. Bhd.	

**Tajuk Kerja** : TypeTest For Precast Pretensioned Spun Concrete Piles      **Nombor Ujian** : SPB/42/R5/A1620/03

Sample 1

1.	Calculated Cracking Bending Moment (Mcc)	4.68 Ton-m
		46.8 kN-m
2.	Calculated Load To Achieve Mcc (Pcc)	29.8 kN
		2.98 Ton
3.	Calculated Load To Achieve 1.5 times Mcc	4.50 Ton
4.	Rate of Loading	0.07 N/mm <sup>2</sup> /sec.
		10.00 psi/sec.
5.	Ram Area	6.49 in <sup>2</sup>
		4187.09 mm <sup>2</sup>

No.	Loading	Observation
1.	Loading to Pcc : 2.98 tonne Gauge reading : 1020 psi	Gauge reading at Pcc : 1020 psi Remark: Two (2) hairline cracks < 0.05mm were observed & checked with feeler gauge.
2.	Increase load to achieve 1.5 times Mcc (4.50 tonne) Gauge reading : 1530 psi	Crack width : < 0.05mm Condition of pile : pile was intact.

**Remarks:** The above 'Bending Test' was complied, please refer to test results on page 6 of 6.

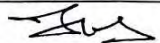
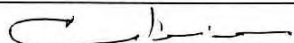
<b>Disediakan Oleh</b>	<b>Disemak Oleh</b>
Tee Eng Kheng	Azman Idris
	

LAPORAN UJIAN	
<b>Tarikh Ujian</b> : 18/9/03	<b>Muka Surat:</b> 6 / 6
<b>Tempat Ujian</b> : Industrial Concrete Products Bhd.	
<b>Pegawai Yang Menguji</b> : Azman Idris & Tee Eng Kheng	
Laporan ujian ini <b>HANYA</b> meliputi sampel-sampel terpilih yang diuji di kilang dan <b>BUKAN</b> merupakan sijil kelulusan atau perakuan penentuan kualiti. Laporan ujian ini hendaklah digunakan dalam bentuk penuh dan <b>TIDAK BOLEH</b> digunakan untuk sebarang bentuk publisiti tanpa mendapat kebenaran bertulis daripada pihak IKRAM QA Services Sdn. Bhd.	
<b>Tajuk Kerja</b> : TypeTest For Precast Pretensioned Spun Concrete Piles <b>Nombor Ujian</b> : SPB/42/R5/A1620/03	

Sample 1

LAPORAN UJIAN		
Time (sec.)	Load (psi) [Gauge reading]	Remarks
0	0	Ram wt. & spreader beam = 0.43 tonne (146 psi) before initial load was applied.
20	200	No crack was observed.
40	400	- Ditto -
60	600	- Ditto -
80	800	- Ditto -
102	1020	<b>Pcc</b> at gauge reading = 1020 psi (2.98 ton)  Two (2) hairline cracks < 0.05mm were observed & checked with feeler gauge.
120	1200	Another three (3) hairline cracks < 0.05mm were observed
140	1400	Another two (2) hairline cracks < 0.05mm were observed & cracks width (< 0.05mm) prior to this were intact.
153	1530	<b>(1.5 x Mcc</b> at gauge reading = 1530 psi (4.50 ton)  Two (2) cracks width 0.05mm were measured with feeler gauge & the others cracks (< 0.05mm) width were remained intact.
<b>Remarks :</b> The above 'Bending Strength Test' was complied. Pressure Gauge (Tecsis, Germany), 1 div. = 50 psi, Max. capacity: 2,300 psi Certificate No.: NP0247/03 Calibrated by : SEA Metrology Services Sdn. Bhd. Date due : 30/4/04 Ram wt. & spreader beam = 0.43 tonne (146 psi)		

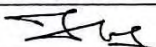
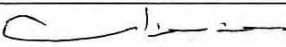
Disediakan Oleh	Disemak Oleh
Tee Eng Kheng	Azman Idris
	

## **APPENDIX C3**

- 3) Bending Test Report No.SPB-01-06  
dated 9/1/2006
  - i) Dia.250mm X 12m

**IKRAM QA SERVICES Sdn Bhd** (479565 A)

Blok 5, Tingkat 1, Taman Ilmu Ikram (Ikram Park), Jalan Serdang-Kajang, 43000 Kajang,  
Selangor Darul Ehsan, Malaysia.  
Tel: (603) 8738 3388 Fax: (603) 8736 7254  
e-mail: ikramqa@ikram.com.my  
http://www.ikram.com.my



(Ahli Kumpulan IKRAM Sdn Bhd)

FULL TYPE TEST REPORT			
Report No.	SPB-01-06	Date	09/01/06
Total No. Of Pages.	9 pages	Page	1 of 9
Job Title	For Additional Size For Existing Certificate of Conformity For Precast Pretensioned Spun Concrete Piles		
Certificate no.	IKRAM/T002/C0103/N2900		
Name and address of Applicant	Industrial Concrete Products Bhd., Tingkat 2, Wisma IJM, Jalan Yong Shook Lin, P.O. Box 191, 46720 Petaling Jaya Selangor Darul Ehsan. (u/p: Ir. Yue Kam Fatt)		
Country of Origin	Malaysia		
Name and address of Manufacturer	Industrial Concrete Products Bhd., Lot 110, Kawasan Perindustrian Gong Badak, 21300 Kuala Terengganu.		
Product	Precast Pretensioned Spun Concrete Piles		
Product Standard	MS 1314:Pt. 1:1993		
Particulars of Product	Diameter: 250mm		

Thank you,

For,  
IKRAM QA Services Sdn. Bhd.  
(TUAN HAJI YAHYA HAJI ARIFFIN)  
DIRECTOR - CERTIFICATION

This report covers samples that are selected at the applicant/importer designated premises/factory for testing ONLY and this report IS NOT an approval certificate of conformity. This report shall be in full and cannot be used for any publicity without obtaining written approval from IKRAM QA Services Sdn. Bhd.

**FULL TYPE TEST REPORT**

Cl.	MS 1314:Pt. 1:1993 requirements	Result of type test or observation	Compliance to Specification																	
9.	<p><b>Bending strength test</b> When required one or more piles may be selected for bending strength test. The bending strength test of pile body shall be made by the application of vertical load P to the centre of the span, on the pile laid on two supports which has a span equal to 3/5 of its length as shown in Appendix B. Any countermeasure may be taken to prevent the occurrence of local fractures at the loading or supporting points before the pile breaks by bending.</p> <p>The bending moment shall be calculated from the following equation:- <math>M = 1/40 WL + P/4 (3/5 L - 1)</math></p> <p>Where, M = Bending moment (kN-m) P = Applied load (kN) L = Length of pile (m) W = Weight of pile (kN)</p> <p><b>The observed breaking bending moment (Mu) shall be the largest P value observed until the pile breaks or until the ratio Mu/Mc exceeds the specified requirement, whichever reaches first.</b> The bending strength test of <b>pile joint</b> shall be as above provided the joint is positioned at the centre of the span. The ratio of observed breaking bending moment to cracking bending moment Mu/Mc comply shall be as follows:</p> <p>Spun pile Class A : Mu/Mc &gt; 1.5 Class B : Mu/Mc &gt; 1.8</p> <p>Where, Mu is the observed breaking bending moment; Mc is the cracking bending moment given in Table 1. Table 1: Cracking bending moment for spun piles</p> <table border="1"> <thead> <tr> <th>Outside dia.</th> <th>Class</th> <th>Cracking bending Moment, Mc</th> </tr> </thead> <tbody> <tr> <td>250mm</td> <td>A</td> <td>1.7 ton</td> </tr> <tr> <td>300mm</td> <td>A</td> <td>2.5 ton</td> </tr> </tbody> </table>	Outside dia.	Class	Cracking bending Moment, Mc	250mm	A	1.7 ton	300mm	A	2.5 ton	<p><b>1) Bending strength on body</b> Sample 1 - Ø 250mm x 12m Mc = 1.7 ton-m Mu = 2.55 ton-m</p> <p align="center"><b>Crack observation</b></p> <table border="1"> <thead> <tr> <th>At Mc</th> <th>Mu (1.5 times Mc)</th> </tr> </thead> <tbody> <tr> <td>No crack observed</td> <td>No crack observed &amp; pile was intact.</td> </tr> </tbody> </table> <p><b>2) Bending strength on pile joint</b> Sample 2 &amp; 3 - Ø 250mm x 6m + 6m (Welded joint) Mc = 1.7 ton-m Mu = 2.55 ton-m</p> <p align="center"><b>Crack observation</b></p> <table border="1"> <thead> <tr> <th>At Mc</th> <th>Mu (1.5 times Mc)</th> </tr> </thead> <tbody> <tr> <td>No crack Observed</td> <td>No crack observed &amp; pile's joint was intact.</td> </tr> </tbody> </table>	At Mc	Mu (1.5 times Mc)	No crack observed	No crack observed & pile was intact.	At Mc	Mu (1.5 times Mc)	No crack Observed	No crack observed & pile's joint was intact.	<p>1) Complied</p> <p>2) Complied</p>
Outside dia.	Class	Cracking bending Moment, Mc																		
250mm	A	1.7 ton																		
300mm	A	2.5 ton																		
At Mc	Mu (1.5 times Mc)																			
No crack observed	No crack observed & pile was intact.																			
At Mc	Mu (1.5 times Mc)																			
No crack Observed	No crack observed & pile's joint was intact.																			

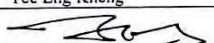
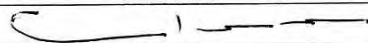
<b>Prepared by</b> Tee Eng Kheng	<b>Verified by</b> Azman Idris
	

# **Structural Performance of ICP PHC Piles**

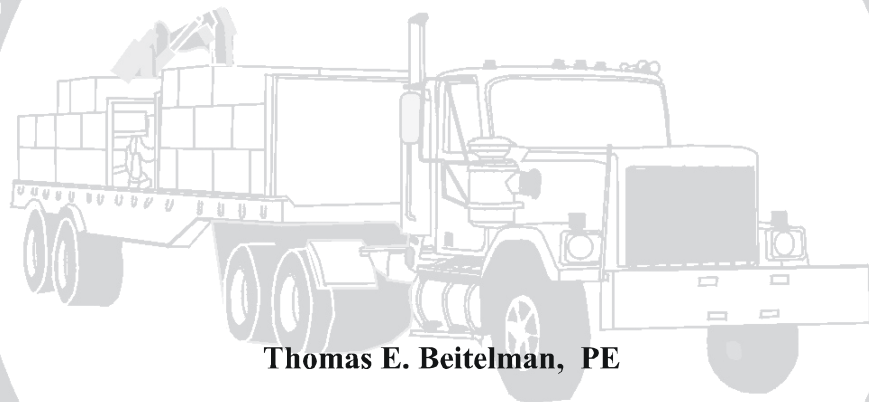

**Thomas E. Beitelman, PE**

September, 2001

Structural Research Center  
2007 E. Dirac Drive  
Tallahassee, FL 32310

Structures Research Group  
Structures Design Office  
Florida Department of Transportation

## **Introduction/Background**

During the first half of 2001, an innovative product was brought to the attention of the Florida Department of Transportation. The product is a “spin-cast” prestressed concrete pile section distributed by “Pipe and Piling Concrete Products Corp.,” and produced in Malaysia. This product, herein referred to as “ICP-PHC” piles is claimed by the manufacturer to be superior and cost competitive with standard domestically produced pile sections. These claims are primarily through their application of a high strength prestressing bar as opposed to the 7-wire prestressing strand commonly used. These bars, which are not used domestically, are produced to meet the Japanese equivalent of ASTM, and according to which, are spot weldable without degradation of properties. The bars are stressed between two steel plates prior to the application of concrete, and left in place such that the plates become an integral portion of the pile system. These plates serve two purposes, first, to act as an anchorage plate for the bars, second, to serve as the splicing system. Leaving the anchor blocks in place after the concrete cures creates the situation where the pile is stressed uniformly along the entire length, as opposed to standard practice where loss of prestress occurs at the ends. The splicing procedure consists of butting two of the anchorage plates together and performing a full penetration groove weld, a procedure that is extremely rapid and simple to perform. Further benefits to the fabrication process involve the welding of the spiral reinforcement to the prestressing bars prior to the stressing operation.

The distributor, “Pipe & Piling Concrete Products Corp.,” sought acceptance of this product for use in Florida Department of Transportation bridge structures. However, due to unknowns that primarily have to do with the mechanical properties of the prestressing bars, and the welding of the spiral reinforcement cage to these bars, full scale testing was performed.

## **Material Properties**

The ICP Piles are manufactured in a wide variety of sizes and lengths with design criteria shown in Table 1<sup>7</sup>. Concrete strength is reported by the manufacturer as  $f'_c = 10$  ksi (70 MPa) and a cube strength of 11.7 ksi (80 MPa).

Nominal Diameter	Class	Nominal Wall Thickness	Length	Nominal Weight	Prestress Bar Dia.			Area of Concrete
					7.1 (0.28") No.	9.0 (0.35") No.	10.7 (0.42") No.	
mm (in)		mm (in)	m (ft)	kg/m (lbs/ft)				mm <sup>2</sup> (in <sup>2</sup> )
250 (9.8)	A	55 (2.2)	6-12 (20-39)	88 (59)	6			33694 (52.2)
300 (11.8)	A	60 (2.4)	6-15 (20-49)	118(79)	8			45239 (70.1)
350 (13.8)	A	70 (2.8)	6-16 (20-53)	160 (108)		6		61575 (95.4)
400 (15.7)	A B C	80 (3.1)	6-20 (20-66)	209 (140)		8 10 12	or 8	80425 (124.7)
450 (17.7)	A B C	80 (3.1)	6-20 (20-66)	242 (163)		8 10 12		92991 (144.1)
500 (19.7)	A B C	90 (3.5)	6-24 (20-79)	301 (202)		10 12 15	or 10	115925 (179.7)
600 (23.6)	A B C	100 (3.9)	6-30 (20-98)	408 (274)		14	12 14	157080 (243.5)
700 (27.6)	A B C	110 (4.3)	6-46 (20-151)	530 (356)		20	16 20	203889 (316.0)
800 (31.5)	A B C	120 (4.7)	10-46 (33-151)	667 (448)		24	20 24	256354 (397.3)
840 (33.1)	A B C	120 (4.7)	10-40 (33-131)	706 (474)		24	24 28	271434 (420.7)
900 (35.4)	A B C	130 (5.1)	10-44 (33-144)	818 (550)		28	24 28	314473 (487.4)
1000 (39.4)	A B C	140 (5.5)	10-40 (33-131)	983 (661)			24 32 36	378248 (586.3)

**Table 1 – Manufacturer Data for ICP PHC Piles**

Nominal Diameter	Class	Effective Prestress	Cracking Moment Capacity	Nominal Moment Capacity	Service Axial Load	Nominal Axial Load
mm (in)		N/mm <sup>2</sup> (psi)	kN-m (k-ft)	kN-m (k-ft)	kN (kips)	kN (kips)
250 (9.8)	A	6.3 (914)	15 (11)	30 (22)	724 (163)	1226 (276)
300 (11.8)	A	6.3 (914)	26 (19)	47 (35)	972 (219)	1647 (370)
350 (13.8)	A	5.7 (827)	38 (28)	69 (51)	1334 (300)	2252 (506)
400 (15.7)	A	5.8 (841)	58 (43)	103 (76)	1741 (391)	2939 (661)
	B	6.9 (1001)	65 (48)	126 (93)	1711 (385)	2912 (655)
	C	7.6 (1102)	91 (67)	171 (126)	1972 (443)	3361 (756)
450 (17.7)	A	5.1 (740)	73 (54)	122 (90)	2031 (457)	3416 (768)
	B	6.0 (870)	81 (60)	146 (108)	2002 (450)	3388 (762)
	C	7.2 (1044)	91 (67)	171 (126)	1972 (443)	3361 (756)
500 (19.7)	A	5.1 (740)	100 (74)	167 (123)	2531 (569)	4258 (957)
	B	6.0 (870)	111 (82)	197 (145)	2502 (562)	4230 (951)
	C	7.1 (1030)	121 (89)	226 (167)	2471 (556)	4201 (944)
600 (23.6)	A	5.2 (754)	171 (126)	282 (208)	3423 (770)	5764 (1296)
	B	6.2 (899)	188 (139)	335 (247)	3380 (760)	5723 (1287)
	C	7.1 (1030)	205 (151)	381 (281)	3339 (751)	5684 (1278)
700 (27.6)	A	5.7 (827)	277 (204)	469 (346)	4417 (993)	7456 (1676)
	B	6.3 (914)	294 (217)	522 (385)	4379 (984)	7420 (1668)
	C	7.5 (1088)	334 (246)	635 (468)	4296 (966)	7341 (1650)
800 (31.5)	A	5.5 (798)	393 (290)	649 (479)	5570 (1252)	9390 (2111)
	B	6.3 (914)	427 (315)	751 (554)	5508 (1238)	9331 (2098)
	C	7.3 (1059)	473 (349)	880 (649)	5425 (1220)	9253 (2080)
840 (33.1)	A	5.2	431 (318)	690 (509)	5918 (1330)	9962 (2240)
	B	6.0 (870)	468 (345)	797 (588)	5856 (1316)	9903 (2226)
	C	7.0 (1015)	515 (380)	937 (691)	5773 (1298)	9825 (2209)
900 (35.4)	A	5.2 (754)	534 (394)	860 (634)	6854 (1541)	11539 (2594)
	B	6.1 (885)	588 (434)	1021 (753)	6767 (1521)	11457 (2576)
	C	7.1 (1030)	641 (473)	1169 (862)	6685 (1503)	11379 (2558)
1000 (39.4)	A	5.2 (754)	723 (533)	1112 (820)	8241 (1853)	13876 (3119)
	B	6.7 (972)	839 (619)	1501 (1107)	8075 (1815)	13719 (3084)
	C	7.4 (1073)	898 (662)	1662 (1226)	7992 (1797)	13641 (3067)

*Table 1 (cont.) – Manufacturer Data for ICP PHC Piles*

The bars are fabricated under the trade name “ULBON” and manufactured in accordance with Japanese Industrial Standard JIS G 3137 (Small size-deformed steel bars for prestressed concrete). The steel is classified as a low carbon steel and with the “...application of an induction heat treatment process...”, ULBON is reported to have low relaxation characteristics similar to that of low relaxation prestressing strands, and is reported to be spot weldable with minimal change in mechanical properties. Minimum tensile strength of the bars is reported to be 205.9 ksi (1,420 MPa) and yield strength of 184.9 ksi (1,275 MPa) measured at a 0.2% offset. Test results from the manufacturer report tensile and yield strengths greater than the specified design value, as shown in Table 2. Table 2 also shows the results of spot welding tests on the bars, as well as a discrepancy in the JIS Specification, where the value reported for Yield Strength exceeds that for the Tensile Strength.

Specimen No.	Tensile Strength	Yield Point	Breaking Portion *
	N/mm <sup>2</sup> (ksi)	N/mm <sup>2</sup> (ksi)	
1	1.470 (213.2)	1.441 (209.0)	N
2	1.480 (214.7)	1.451 (210.5)	S
3	1.470 (213.2)	1.441 (209.0)	N
4	1.480 (214.7)	1.451 (210.5)	N
5	1.470 (213.2)	1.441 (209.0)	S
6	1.470 (213.2)	1.441 (209.0)	N
JIS Spec.	1.420 (206.0)	1.425 (206.7)	-

\* - N = Not in Welded Portion, - S = At Spot Weld

**Table 2 – Tension Test With Spot-Welding Results For ULBON as Reported By Bar Manufacturer.**

One note regarding the tensile strength of the bars lies in the ultimate tensile strength reported by the distributor. There appears to be an inadvertent error in the conversion of the ultimate tensile strength of 1,420 MPa to 220.4 ksi, in that the U.S. conversion should have been listed as 205.9 ksi.

### **Experimental Investigation**

Structural evaluation of the ICP-PHC pile system yields several areas of concern that must be addressed before acceptance for use by the FDOT. The amount of concrete provided as cover for the main reinforcement is, on average, 1" for the samples sent to the Structures Research Center. The minimum FDOT requirement however is 3". Also, the steel load plates were provided to the Structural Research Center without any protective coating. The primary concern however, is in the structural performance of the section and the material characteristics of the prestressing bars. The structural evaluation was performed on sample 14" diameter sections and bar samples provided to the Structural Research Center by the manufacturer. Cross section details are shown in Figure 1.

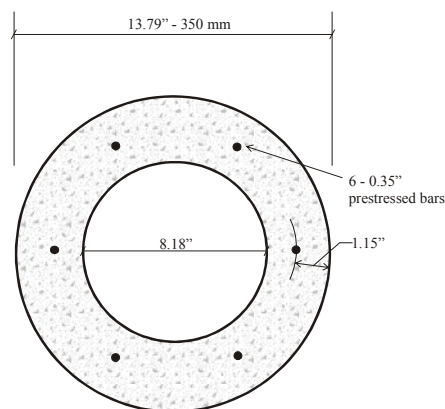

**Figure 1 – Cross Section Details**

Since the prestressing bars are not produced in the United States, it is necessary to perform standard tension tests to establish the validity of the manufacturer reported material properties. Test samples consisted of both virgin bars and bars that had received welding to establish whether any detrimental effects from the welding process occur as evidenced by hardening or crystallization of the metal.

The sample pile sections were subjected to static flexural and flexural fatigue loading. As has been documented and researched, it is known that American prestressing steels are detrimentally affected if they are welded<sup>1</sup>. This effect manifests itself in both fatigue performance and ductility of the section where premature fatigue failure occurs and/or ductility of the section is either limited or the section becomes classified as “brittle”. Additional testing to evaluate the effectiveness of the splicing system was performed, using specimens fabricated from the remains of test specimens that had previously been tested under static loading.

### **Test Methods**

*Tension Testing* – The AASHTO Standard Method of Test for “Mechanical Testing of Steel Products,” designation T 244-92 (ASTM designation A 370-92) was followed to determine the tensile properties of the bars. Bars were provided in 48” lengths and gripped using a hydraulic “V” grip wedge system. The combination of wedges at both ends of the bars leaves a 36” gauge length, which satisfies the 24” minimum requirement of AASHTO. Four electrical resistance strain gauges were used to instrument each specimen, with instrumentation applied at the center of the gauge length. The entire assembly is placed in the gripping portion of an MTS-550 universal material testing system load frame (see Figure 2). This load frame is capable of applying a force of 550 kips in tension or compression and is fully controllable in terms of load rate, whether through displacement or load control, to satisfy the requirements of the testing procedure.

Following the AASHTO test procedure, each bar was loaded to approximately 10 percent of the expected minimum breaking strength of the specimen, which was assumed to be 5 kips, prior to beginning the test. The load rate was set at 125  $\mu\epsilon$ /second and proceeded until rupture of the specimen. The load, stress and strain were all monitored using a high speed data acquisition system with readings being taken twice every second throughout the duration of the test.

The instrumentation used was as follows:

- 1 – A minimum of four electrical resistance strain gauges with an accuracy of  $\pm 5 \mu\epsilon$  and a maximum elongation of 20,000  $\mu\epsilon$ .
- 2 – The test frame load cell with an accuracy of  $\pm 50$  lbs with the most recent calibration occurring in April 2001.



**Figure 2 - Bars Placed in Tension Testing Apparatus**

*Static Flexural Testing* – Full bridge electrical resistance strain gauges capable of measuring both strain and crack width were mounted at regular intervals along the length of the specimen. Deflection measurements were taken at mid-span, load points and both supports using Linear Voltage Displacement Transducers (LVDTs). Load was measured using a 55 kip capacity load cell mounted on the load distribution frame. All gauges were connected and monitored by a data acquisition system. Test setup and instrumentation details are shown in Figure 3. The test combination of test span and point of load application were selected such that the largest reasonable region of constant moment was available, while the load points are not within the shear critical region.

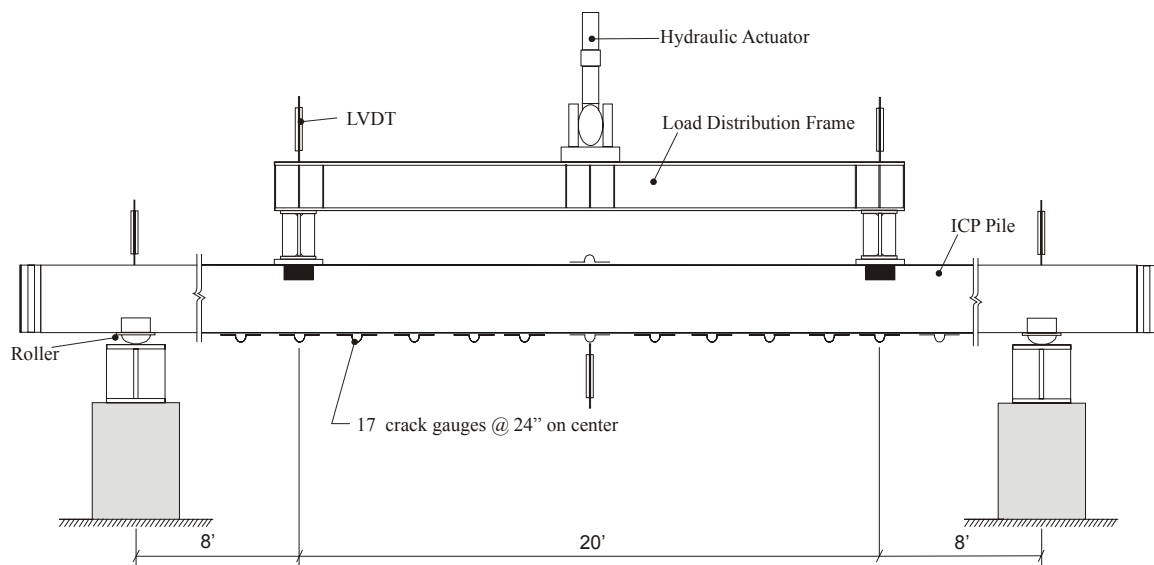

**Figure 3 – Test Setup and Instrumentation Details For Static Test**

The piles were tested as beams for flexural effects under four-point static loading with a simple span of 36 ft. The loads were applied at 8 ft. from the supports using an electronically controlled hydraulic actuator. Incremental loading was applied in 500 lb intervals up to the ultimate collapse of the beam. Strain, deflections and the applied load were recorded at every load increment. Upon reaching the ultimate capacity, the normal test procedure is to release the load slowly and the strain and deflection data recorded during unloading. In the case of brittle failure however, reaching ultimate capacity results in fracture of the specimen, and load is removed immediately.

*Fatigue Loading* – The fatigue specimens were subjected to a four point loading as shown in Figure 4. Application of the fatigue load was achieved by means of an electrohydraulic actuator programmed to deliver a sinusoidal loading causing an 18 ksi change in stress in the bottom bars of the specimens as per AASHTO LRFD criteria (section 5.5.3.3)<sup>2</sup> at a frequency of 2 Hz.

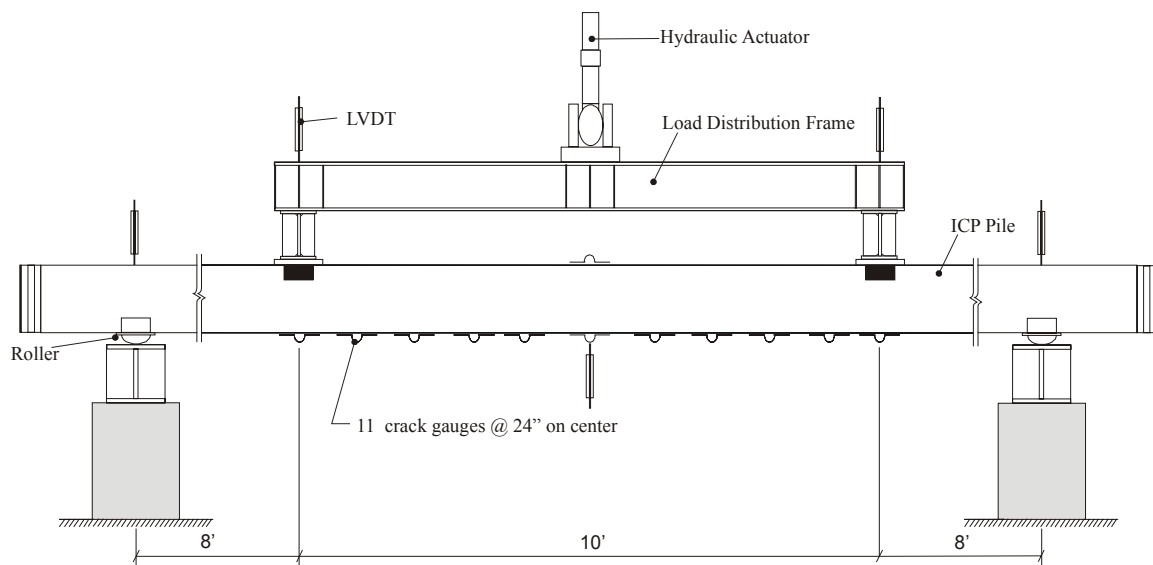

**Figure 4 – Test Setup and Instrumentation Details for Fatigue Test**

Elastomeric bearing pads were used at the supports, and a lateral restraining system of bars was also used to ensure rotational stability of the cross section during testing. The loading was monitored using a load cell resistant to cyclic degradation. Deflection was measured at the supports, load points and mid-span using LVDTs. Strains were monitored at equal increments along the length of the beam using electrical resistance strain gauges. All instruments were connected to a high speed data acquisition system, which allows for continuous monitoring of the test system throughout the investigation. Loading was halted at various cycle increments during the testing and static load was applied incrementally up to the maximum fatigue load.

## **Test Results**

*Tension Tests* – Table 3 summarizes the results observed during the tension testing of the bar specimens:

<b>Welded</b>			<b>Un-Welded</b>		
Specimen #	$f_y$	$f_u$	Specimen #	$f_y$	$f_u$
1	199.3	211.9	1	205.8	211.2
2	201.5	213.3	2	198.4	210.3
3	NA	199.3	3	201.5	210.5
4	203.7	212.9	4	198.9	212.6
5	203.7	210.3	5	200.8	210.5
6	203.6	211.9	6	199.4	210.5
7	203.4	211.9	7	202.0	210.2
8	205.3	212.9	8	199.9	212.2
9	199.4	209.0	9	199.1	209.1
Average	202.5*	210.4		200.6	210.8

\*Value excludes specimen #3

**Table 3 – Tension test results**

$F_y$ , the yield stress, is typically achieved at a 1% extension of strain or 10,000  $\mu\epsilon$ , following AASHTO guidelines<sup>3</sup>. However to verify the manufacturer's data, a 0.2% offset method was used, which follows the manufacturer's procedure. Typically, this provides a reasonably similar value to the AASHTO method.

Stress strain curves are shown in Figures 5 and 6 for the un-welded and welded specimens respectively. As can be seen from the stress strain curves and values provided in Table 3, two critical differences occur between the welded and un-welded specimens. First, welded specimen #3 was incapable of achieving the 0.2% yield specification (as shown by the dashed lines on the accompanying Figures), rupturing just before it would have achieved this level. Second, welded specimens #3 and #4 both exhibit minimal ductility beyond the yield level, as opposed to acceptable ductility for all of the un-welded specimens.

An additional difference between the welded and un-welded bars lies in the failure mode. The expected mode of failure for metals subjected to tensile loading is a ductile necking of the specimen and a "ball and socket" appearance at the rupture interface. In all cases, the un-welded bars met this failure mode. However, in all cases the tests for the welded bars resulted in brittle fractures through a weld as seen in Figures 6 - 9. Observing these figures, it can be seen that the fracture occurred through the weld, and the depth of heat penetration from the welding process into the bar is easily seen, demonstrating that some detrimental effect to the bars occurs.

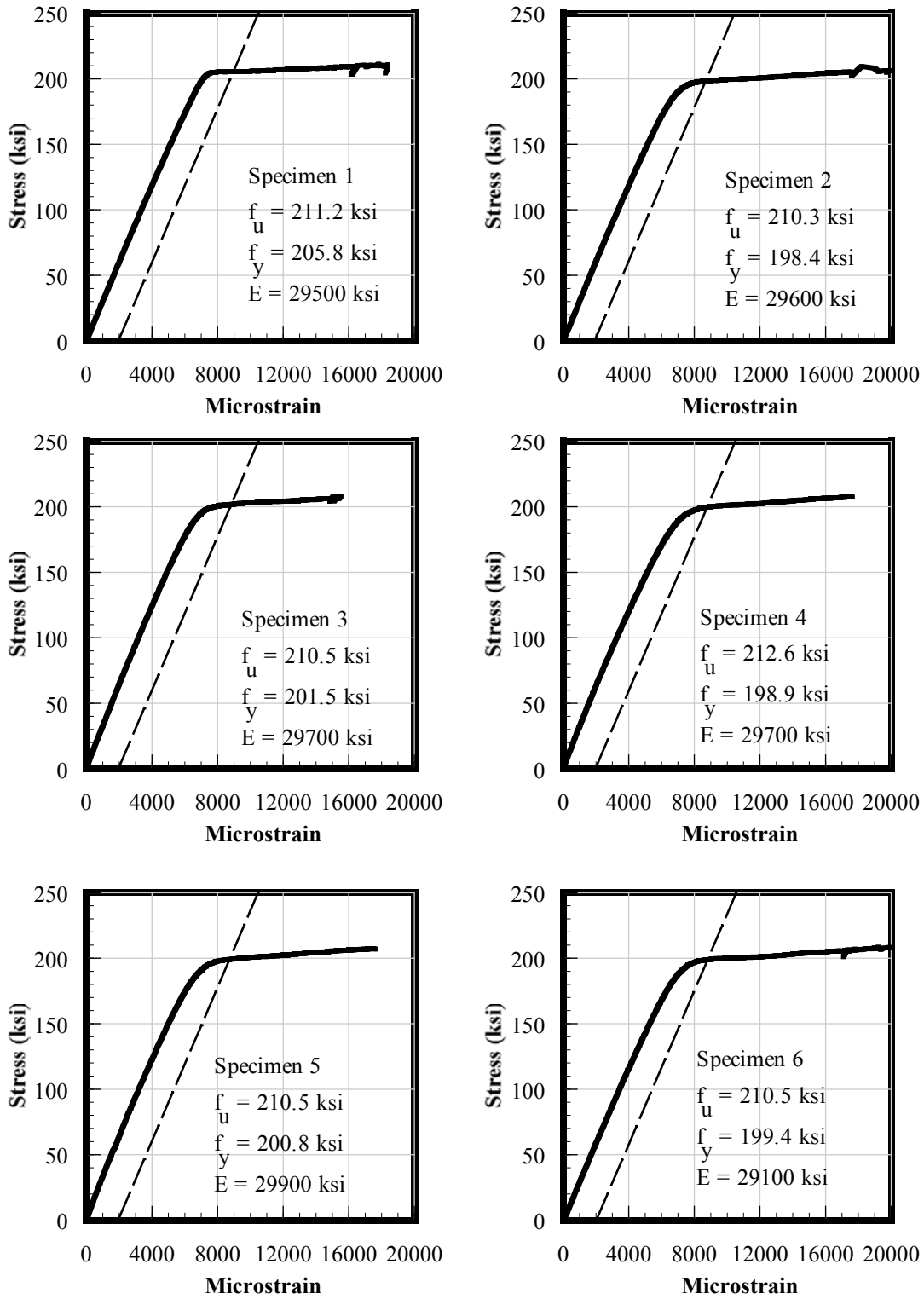

Figure 5 – Stress vs. Strain Results – Un-Welded Specimens

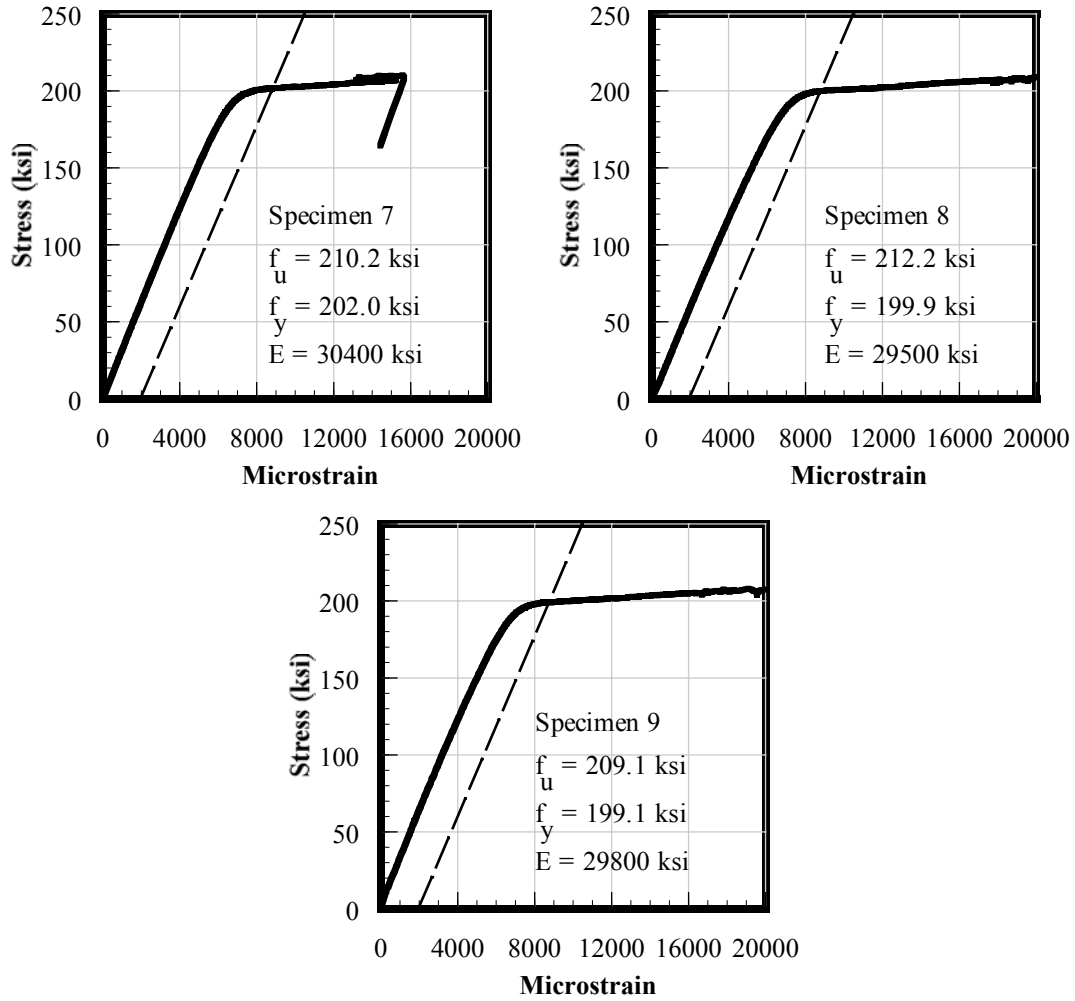

Figure 5 (cont'd) – Stress vs. Strain Results – Un-Welded Specimens

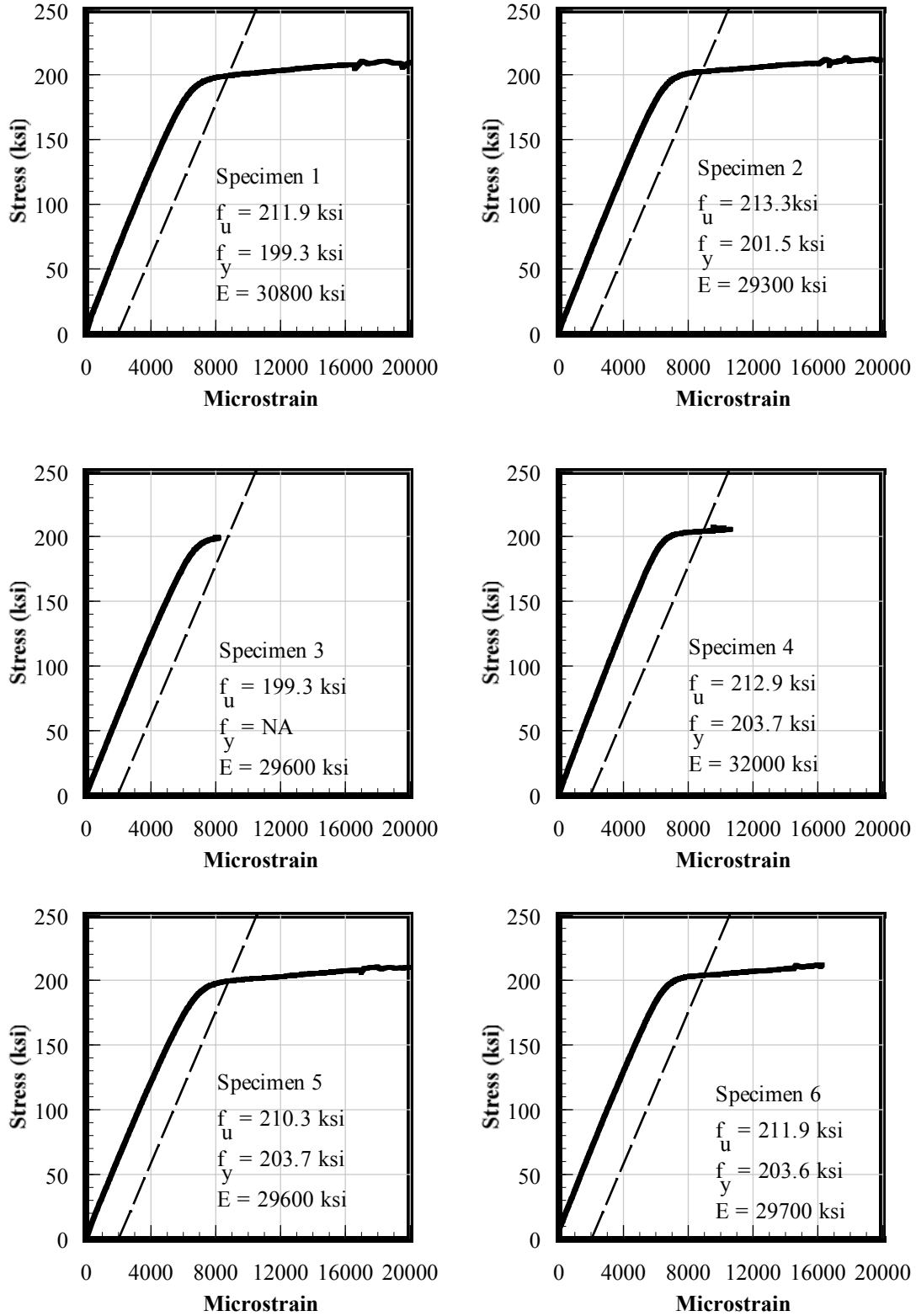

Figure 6 – Stress vs. Strain Results – Welded Specimens

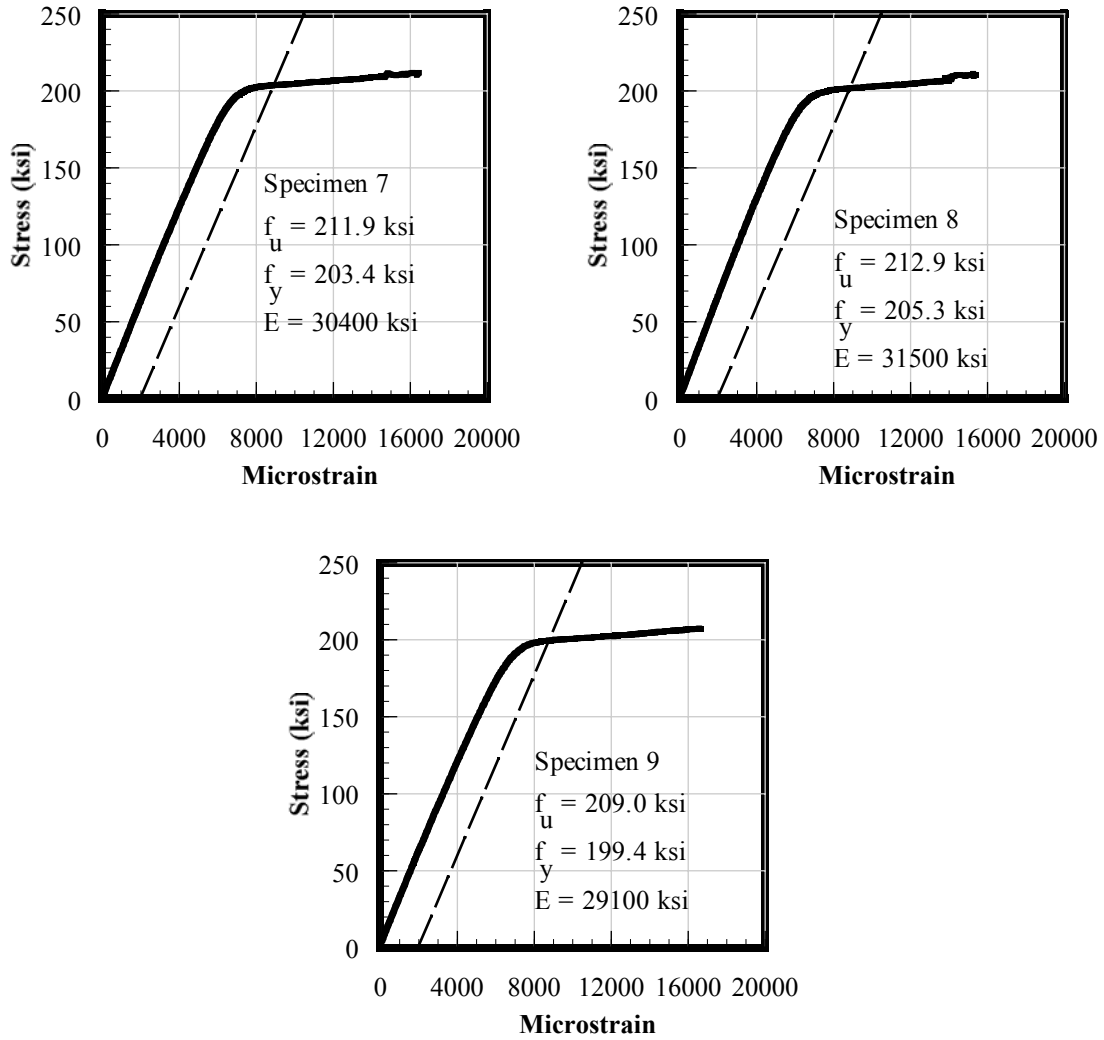

Figure 6 (cont'd) – Stress vs. Strain Results – Welded Specimens



Figure 7 – Fracture Through Weld



Figure 8 – Fracture Through Weld With Spiral Reinforcement Shown



**Figure 9 – Close-up View of Failure Plane Showing Depth of Heat Penetration**



**Figure 10 – Angled Fracture of Bar**

*Static Flexural Test* – The comparison of the applied moment versus deflection for the statically tested specimen is presented in Figure 11. The ultimate load achieved for this specimen was 64.3 kip-ft, which is well above the manufacturer’s specification of 54 kip-ft design capacity, and in close agreement with a calculated capacity of 60.0 kip-ft (achieved using a non-linear analysis). At the ultimate condition, a brittle failure was observed in which the specimen ruptured into two pieces. Close visual examination showed that despite the crushing in the concrete that was evident, four bars had ruptured. Additionally, the rupture of these bars occurred directly at the location where the spiral reinforcement had been welded to the bars (see Figures 12-13).

The crack width that occurred in the maximum moment region was uncharacteristically large however (See Figure 14). PCI (The Prestressed Concrete Institute) recommends a maximum crack width of 0.005” be allowed during handling for members exposed to the weather. The ICP-PHC piling exceeded the 0.005” threshold at 12 kip-ft of load application which is approximately 22% of the reported  $\Phi M_n$ , and 68% of the dead load moment for a 14” section being lifted with supports at 36’. That is, the 0.005” criteria can be exceeded during transportation.

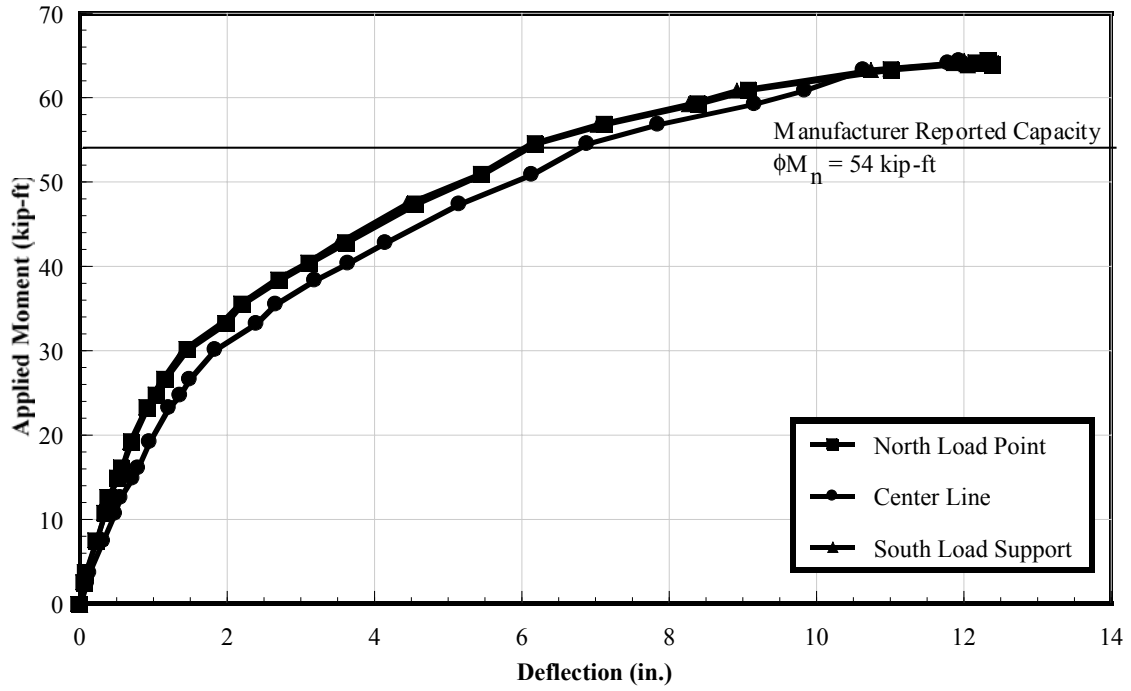

Figure 11 – Applied Moment vs. Deflection – Static Test



Figure 12 – Specimen During Testing



Figure 13 – Specimen After Failure

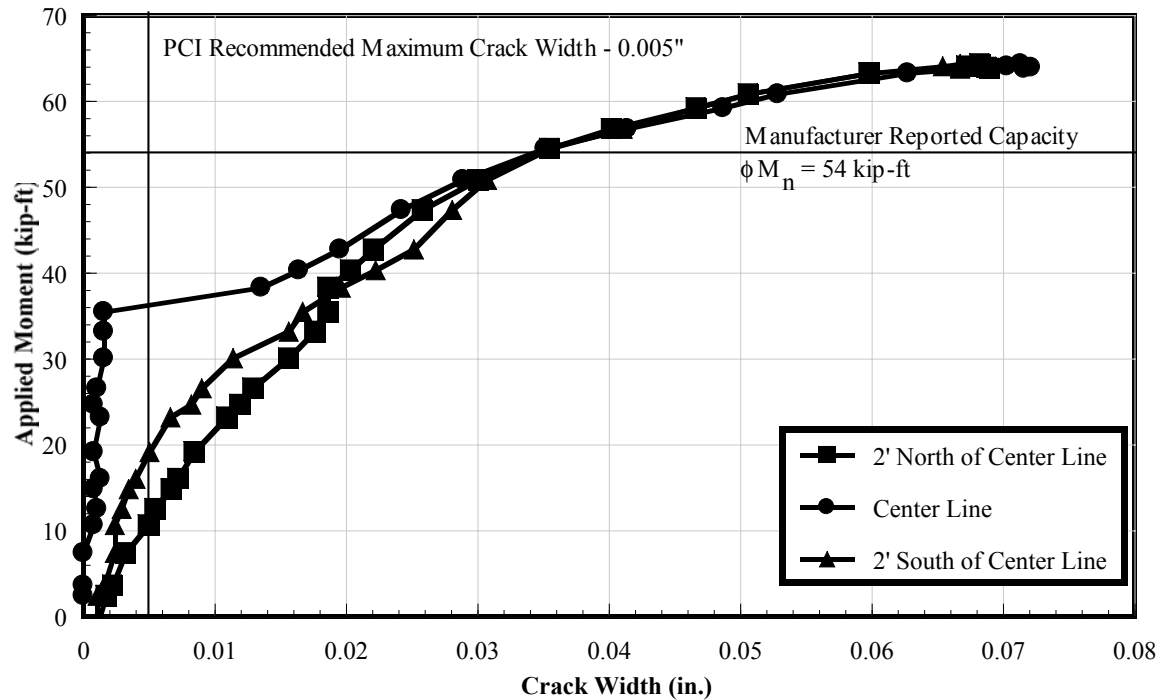
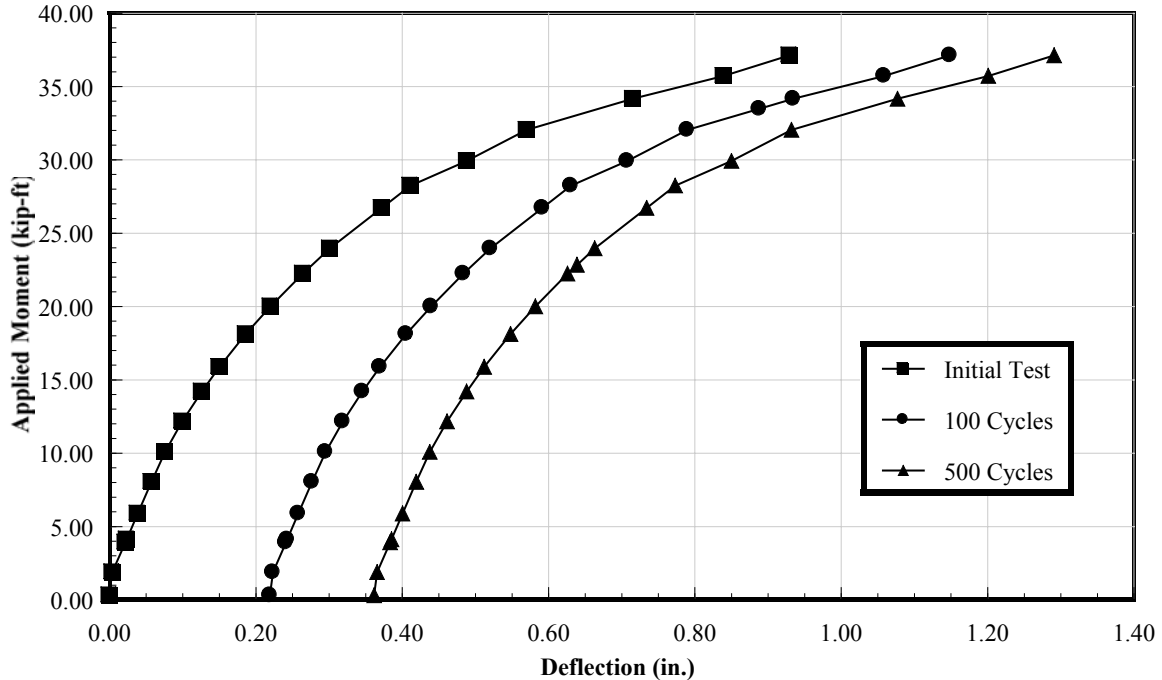

Figure 14 – Applied Moment vs. Crack Width – Static Test

*Fatigue Testing* – In both the static flexural test specimen and the fatigue specimen, the spiral reinforcement was spot-welded to the prestressing bars. In general, this practice is not performed in the United States; due to the influence that welding has with respect to the fatigue performance of prestressing steel. As previously mentioned, AASHTO specifications require that prestressed reinforcement be capable of withstanding an 18 ksi stress change in the cracked section. This initially led to a minimum load that is just above the cracking level of the specimen to a maximum load that is slightly below the ultimate capacity of the section. However, the upper end of the range was too high to perform adequate fatigue testing and resulted in rupture of the specimen at an extremely low cycle count. A second fatigue test was then designed in which the specimen was pre-loaded to the cracked condition, then cyclic loading with a fatigue range below the cracking load was used as the minimum level resulting in the maximum level occurring in a stable load range (maximum applied moment of 37 kip-ft).

The fatigue specimen failed at 4884 cycles, well below any acceptable fatigue capacity, according to AASHTO requirements. Static tests were performed at the initial state, 100 cycles, 250 cycles and 1000 cycles with the next load increment to occur at 5000 cycles if the specimen had not failed prior to that point. A brittle failure was observed at the 4884 cycle mark resulting in rupture of 4 out of 6 prestressing bars. Additionally, as in the static flexural specimen, the rupture of these bars occurred directly at the location where the spiral reinforcement had been welded to the bars (See Figure 15 - 17).



**Figure 15 – Applied Moment vs Deflection – Fatigue Test**



**Figure 16 – Fatigue Specimen at Failure**

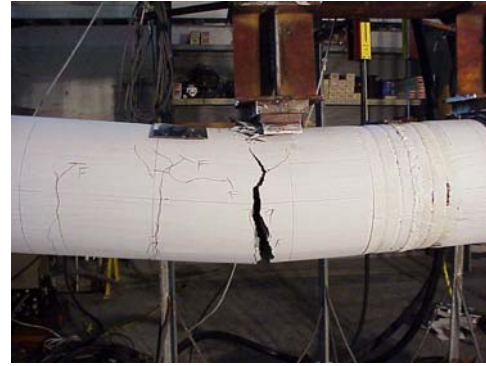

**Figure 17 – Ruptured Bar**

*Splice Testing* – Using the remaining portions of the IPC-PHC piles, personnel at the Structural Research Center performed the splice procedure that is used for the section. The new specimen was then tested in a four-point static flexural test setup similar to the static test detailed above. Failure occurred at a value of 62 kip-ft, which is greater than the manufacturer's specifications, and the failure occurred through the concrete, not the steel splice (See Figures 17-18). Again the failure mode was brittle with 4 out of 6 prestressing bars rupturing at failure, all at the location where the spiral reinforcement had been welded to the bars.



*Figure 17 – Splice Test Specimen Under Load*



*Figure 18 – Failure Crack*

### **Conclusions/Recommendations**

The primary objective of this test program was to determine the feasibility of using the IPC-PHC piling system in Florida Department of Transportation projects. Of primary concern and focus for the test program was the spot-welding that is performed for attaching the spiral reinforcement to the primary reinforcement, especially as relevant to fatigue. Testing, performed by the Structures Research Center, lead to the following conclusions and recommendations:

- 1 – The static flexural response of the ICP-PHC pile was found to acceptable in terms of actual capacity compared to design capacity. However use around areas of high moisture should not be considered unless additional design considerations are made with respect to the crack widths that would be achieved under design loads. The combination of large crack widths with the minimal amount of concrete cover, would provide a direct path for a corrosive agent.
- 2 – Following the AASHTO requirements for fatigue resistance leads to the conclusion that the IPC-PHC system is unacceptable in fatigue critical applications. However, it is extremely important to note that flexural fatigue is not a normally considered condition for piles, and some questions regarding the applicability of the specification toward fatigue testing of such sections arise. Typically, the design conditions for a prestressed concrete pile would result in a significantly lower cyclic load range, and inherently a lower stress range in the reinforcement than the range specified by AASHTO. It is recommended we revisit the AASHTO guidelines if flexural fatigue of prestressed concrete piles does become an issue in the future.
- 3 – The failure mode for all test specimens results in a brittle ultimate situation, where fracture occurs simultaneously with rupture of the prestressing bars. While the section behavior is acceptable up to the ultimate condition, the lack of ductility at failure makes the IPC-PHC piles unacceptable in conditions where ship impact is a concern.

- 4 – Both the splicing detail and splicing procedure for the IPC-PHC piles result in a splice that is fully satisfactory and capable of consistently exceeding the required capacity for the section tested. Further testing however is recommended for larger sections to insure that the change in member scale has no effect.
- 5 – Further study should be performed regarding the detailing aspects of the section, especially as to the amount of concrete cover provided. This note is provided in light of the unknown characteristics of the high-strength, high-performance concrete used in the system, and may result in a different allowance being made for detailing precast prestressed pile sections that utilize such materials and casting methods similar to IPC-PHC piles.
- 6 – Due to the problems with the amount of concrete cover and performance of the welded bars, it is recommended that the IPC-PHC piles not be used in coastal areas. However, if tied steel spirals and an increase in the concrete cover to FDOT requirements were implemented, the IPC-PHC pile system could be acceptable for all conditions.

### **Acknowledgements**

The author wishes to express his appreciation to Steven Kert for donation of the test specimens and technical data for the IPC-PHC piles, and to the staff of the Florida Department of Transportation Structures Research Center for their help in the testing phase of this project, especially to Paul Tighe, for all his work.

### **References**

- 1 - *“Manual of Concrete Practice,”* American Concrete Institute 215R-3, 1987.
- 2 - *“LRFD Bridge Design Specifications,”* AASHTO, 1994.
- 3 - *“Standard Specifications for Transportation Materials and Methods of Sampling and Testing,”* AASHTO, Seventeenth Edition, 1995.
- 4 - Naaman, A., *“Prestressed Concrete Analysis and Design – Fundamentals,”* McGraw-Hill Book Company, 1982.
- 5 - Shahawy, M., Beitelman, T., *“Fatigue Performance of RC Beams Strengthened with CFRP Laminates,”* First International Conference on Durability of (FRP) Composites for Construction (CDCC’98), Sherbrooke, Quebec, Canada, August 5-7, 1998.
- 6 - *“Standard Specifications for Highway Bridges,”* AASHTO, 1993.

7 - Technical Information on “ULBON” bars, provided by Steven Kert of Pipe & Piling Concrete U.S.A. Co.