

Aluminum Picket Weld Test

Written By: Will Potter, E.I.

Reviewed By: Marc Ansley, P.E. and Steve Nolan, P.E.

Overview:

An aluminum picket weld test was requested by the Department in order to obtain the strength of the aluminum 5356 filler wire and the 4043 filler wire on the picket connection of index 860 of the FDOT's *Design Standards*. The objective was to test whether the 4043 filler wire has sufficient strength to withstand the design live load and compare it with the current 5356 filler wire. The FDOT's *Design Standards* lists a design live load of 200 lbs concentrated over 1 square foot. According to the dimensions of the picket railing this would conservatively equate to 100 lbf distributed along 12 inches of the picket length.

To perform the tests, two aluminum railing panels were built according to the *Design Standards*, one welded with 5356 filler wire and the other with 4043 filler wire. The picket connections were welded with a 3/16" fillet weld; however, further observations show that it is more of a penetration weld on two sides due to the lack of coping and beta limitation. The panels were constructed with a Type B connection, which allows one end to be non-welded. Each panel contains six 3/4" NPS Schedule 40 pickets. Each rail (outer tube) is a 2" NPS Schedule 40 pipe. All pipes were aluminum alloy 6061 – T6. The test setup consisted of placing 12" timber block centered on the length of the picket and applying a point load in the center of the block with a hydraulic actuator. The load and center displacement were recorded with a data acquisition system. The panel and test layout is shown in Figures 1 and 2.



Figure 1: Panel and Test Layout



Figure 2: Panel and Test Layout

Results:

The results of the tests revealed that the response of the picket to the applied load varies slightly with the type of weld metal used. Of the 11 tests that were performed, five on the 4043 filler wire and 6 on the 5356 filler wire, only two instances occurred where the base of the weld metal fractured. The fractures were on the pickets that had 4043 filler weld, shown in Figure 3. The other tests were halted based on a drop in load due to the non-welded end slipping out of the rail as shown in Figure 4. The test data given in Table 1 provides the maximum attained load with the failure type. Figures 5 and 6 plots the load versus displacement for all tests. The test data indicates that the maximum load values are disparate on the tests when the picket slips, which is due to the inside roughness of each pipe socket being inconsistent.



Figure 3: Fracture at base of weld – 4043 filler wire



Figure 4: Slipping of Non-welded End

Table 1: Test Data

4043			5356		
	Max Load (lbf)	Failure Type		Max Load (lbf)	Failure Type
Test 1	986.4	Weld Fracture	Test 1	1046.6	Slip
Test 2	917.1	Slip	Test 2	866.7	Slip
Test 3	980.6	Weld Fracture	Test 3	1112.4	Slip
Test 4	886.3	Slip	Test 4	865.2	Slip
Test 5	612.6	Slip	Test 5	1162.4	Slip
			Test 6	956.8	Slip

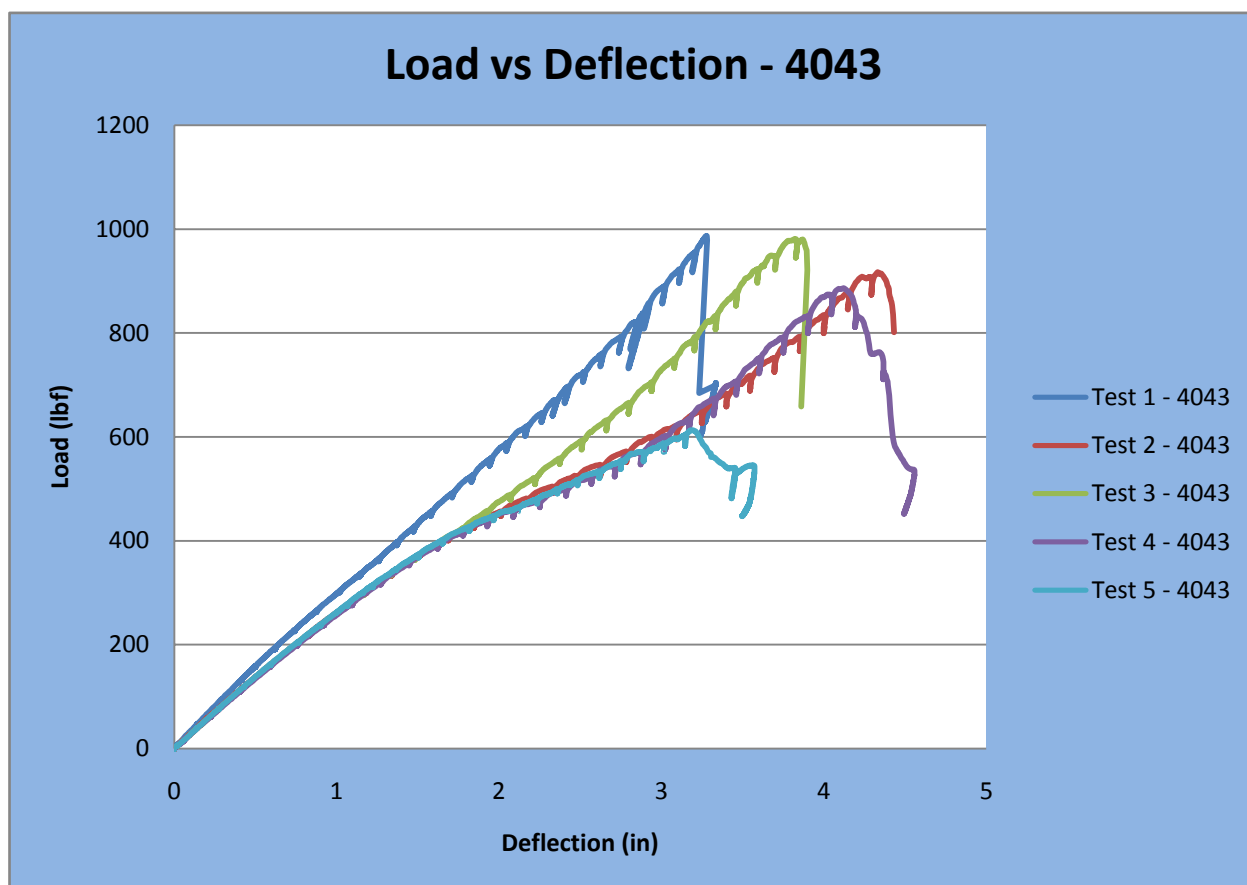

Figure 5: Load vs Displacement – 4043 filler wire

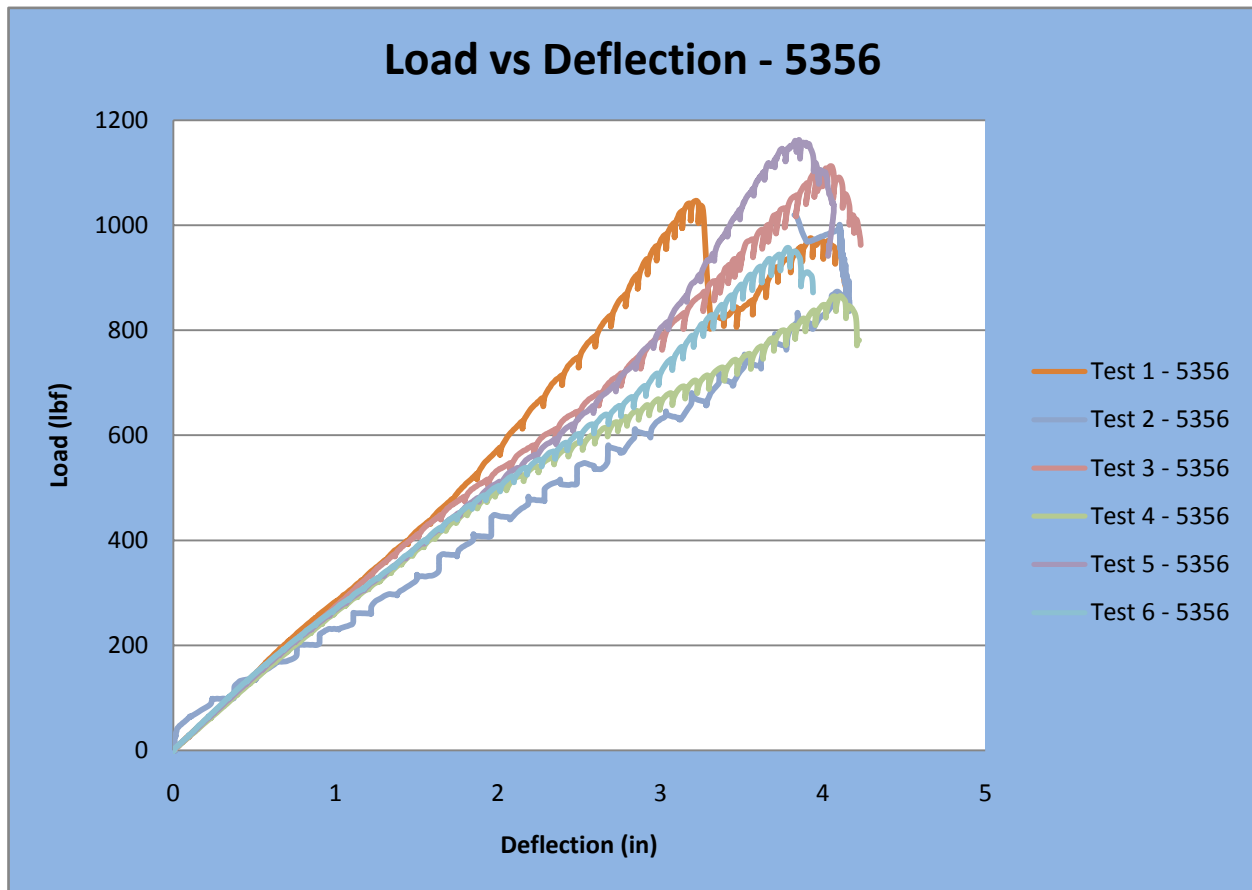

Figure 6: Load vs Displacement – 5356 filler wire

The maximum loads, 986 lbs and 980 lbs, for the 4043 weld metal occurred on the pickets with the fractured weld. The 5356 weld metal had more strength exceeding these values by 6% or more on three separate tests before slipping. The load versus displacement graphs on both types of welds suggest that the pickets yielded between 400 and 600 lbs. Some of the pickets, once yielded, began to slip and eventually developed membrane action before the load drop (Test 2 and 4 – 4043 and Test 3,5, and 6 – 5356). Three tests also demonstrated membrane action immediately after yield with very little slip (Test 1 and 3 – 4043 and Test 1 – 5356). Membrane action occurs once a large amount of deflection has taken place and the picket end is locked in the rail socket, thus allowing the applied load to be resisted axially by the member. Once the load is large enough the weld metal fractures as in the two 4043 welds or slip occurs.

Conclusion:

The test of the aluminum picket weld, in the given setup, indicates that the 4043 filler wire has more than adequate strength to withstand the FDOT’s *Design Standards* design load. The lowest load achieved was 612 lbs in test 5 using 4043 filler wire which is 306% of the total design load of 200 lbs over 1 square foot or 612% of the design load per picket. Joint slippage was the limit for the Test 5

capacity. The lowest load that achieved weld fracture was 980 lbs which is 980% of the design load per picket. The 5356 filler wire provides more strength if slipping of the picket is not a concern, however both filler wires provide more than sufficient strength to withstand the recommended design load. It should be noted that the picket at the non-welded end should be extended far enough into the socket so that premature failure due to rotation does not occur. A minimum embedment length of 1" was provided in the test samples.

Appendix

FORM 625-020-01
STRUCTURES DESIGN - 06/93

	Subject:	Sheet 1 of 1	WPI No.	
	Proposed Picket Weld Load Test		Project No.	
	4043 vs 5356 Filler Alloy		Prepared by SJW	Date 2/26/08
			Checked by	Date

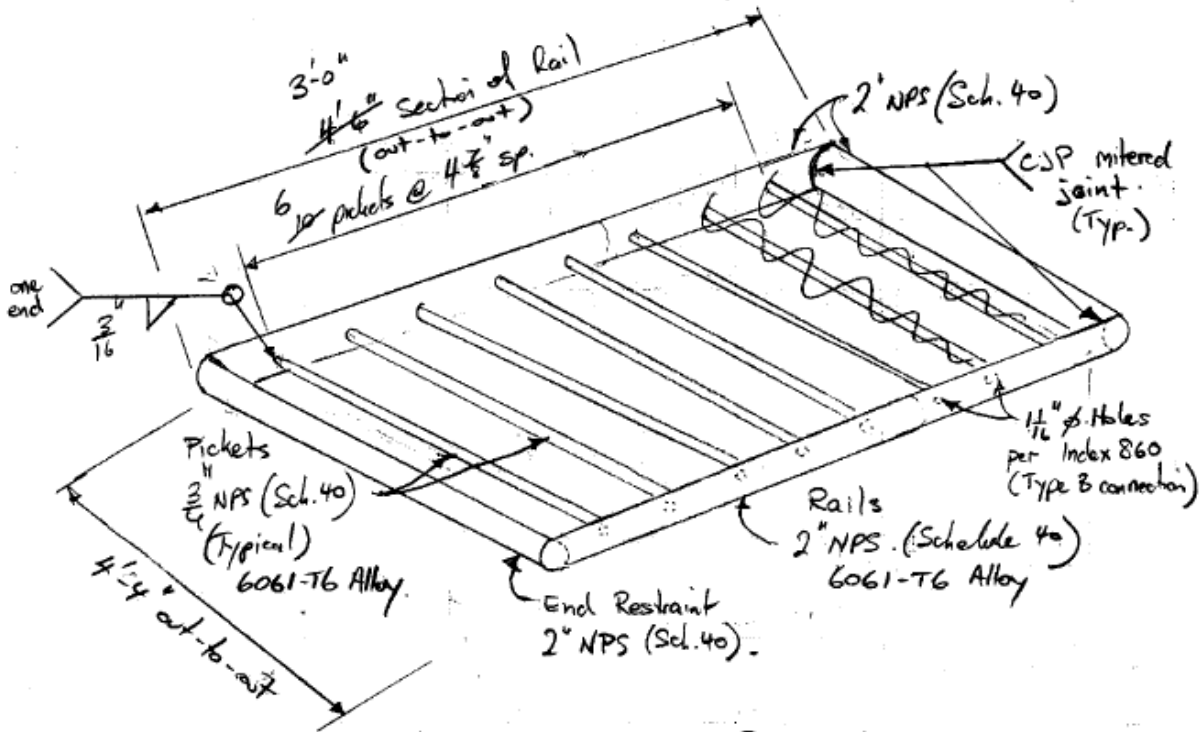

ALUMINUM PICKET RAIL SECTION

Load Test

Load each picket to failure at midspan.

Minimum expected failure load $P = 200$ lbs.

Use 2 test panels. Test Panel A using 4043 Filler Wire

Test Panel B using 5356 Filler Wire.

