



Tongue and Groove Joint Testing



FDOT

Marcus H. Ansley Structures Research Center

Vickie Young, P.E.

Bruno Vasconcelos, E.I.

2016

Introduction

The FDOT M. H. Ansley Structures Research Center (SRC) performed testing to evaluate two precast concrete panels with a tongue and groove joint connection. The testing, conducted within the month of April 2013, involved a static ramp test, a cyclic loading test, and a failure test. For all three tests strain, displacement and load values were measured and recorded. Within the testing, two 12 foot long by 4 foot wide by 8 inch thick panels were joined together with epoxy. The detail of the tongue and groove joint is shown in Figure 1. The $\frac{1}{4}$ inch ($\pm 1/8$ inch) joint was bonded using Sika Hi-Mod Gel. There was only one specimen for this joint. Detailed drawings are shown in the Appendix.

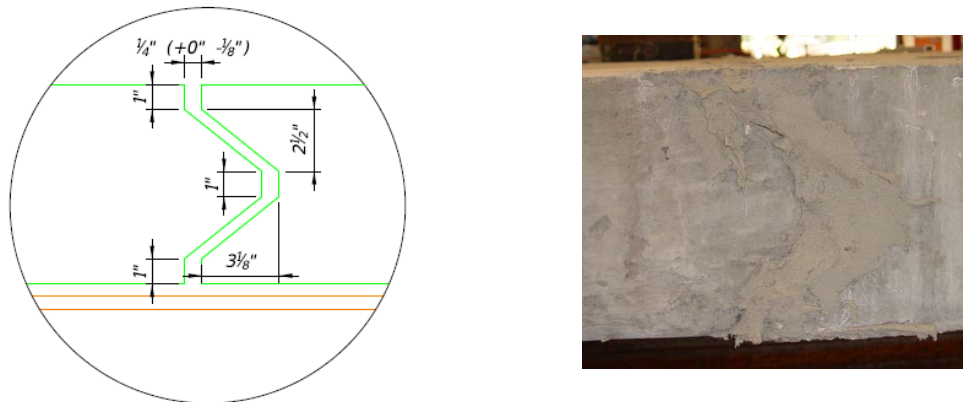

Figure 1 – Tongue and Groove Joint

Materials and Test Setup

The two precast panels used FDOT Concrete Class II Bridge Deck mix. The reinforcement included four No. 4 bars spaced at 12 inches top and bottom with $\frac{1}{4}$ inch top cover and $1\frac{3}{4}$ inch bottom cover. The panels were poured on November 3, 2011 and connected on March 8, 2013. Two six inch diameter voids at each beam line were cored into the panels, to create four shear pockets per panel. One panel was set on two W12x40 by 10 feet long steel beams spaced 8 feet apart. The epoxy agent, Sika Hi-Mod Gel, was applied on the male and female joints and the second panel was set. The panels spanned eight feet with two foot overhangs at each end. Two $\frac{3}{4}$ inch headed studs were welded on the top flange at the shear pocket locations. The grout used to fill the shear pockets and $\frac{1}{4}$ inch gap between the top flange and bottom of panel was BASF Masterflow 928. Figure 2 shows the panels connected and grouted.

The two panels were poured simultaneously but were not match cast. Three separate attempts were made to join the two panels together. The first attempt involved applying the epoxy only to the male side of the joint. This approach proved to be inadequate and did not produce a proper joint between the panels. For the second attempt epoxy was applied to both the male and female grooves resulting in a better joint, but not the desired bond. Finally, on the third attempt, a

generous amount of epoxy was applied to both grooves and the desired joint was made. The tongue and groove joint did not match at the panel edge because the tongue side of the panel was bowed. It is possible that the lack of match casting required a thicker layer of epoxy on the edge to even out the mismatching dimensions.



Figure 2 – Final Connected Panels

The steel beams were elevated onto supports, nine inches from one end and three inches from the other end, resulting in a clear span of nine feet. The actuator applied a point load at the center of a 10 inch by 20 inch bearing pad placed eight inches from the joint, see Figure 3. The 10 inch by 20 inch bearing pad was selected to represent the tire contact area. The first test conducted was the static ramp testing. This test consisted of applying a load at a rate of 0.25 kip/second, until the load reached 15 kips and then it was released. On the first day, this was done for three cycles and on the second day, another three cycles. The 15 kip load was chosen to represent a legal wheel load of 10 kips with a load factor of 1.1 and dynamic load allowance factor of 1.33.

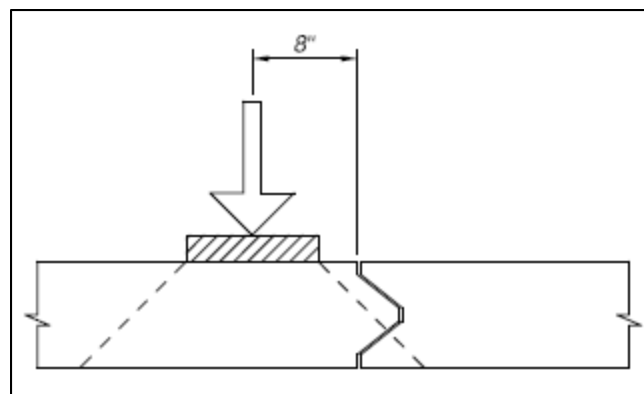

Figure 3 – Load Placement

Once the static test was complete, the actuator was reset to perform a cyclic loading test. A load cycling between 2 and 15 kips at 3 Hz was applied and ran for two million cycles for eight days. The objective of this test was to see how the joint performed under continuous loading. At the conclusion of this test, the joint was tested to failure. The test setup for all three tests can be seen in Figure 4.



Figure 4 – Test Setup

The panels were instrumented with nine strain gages and eight displacement gages. The strain gages were placed at the mid-span of the panels, four on the east panel and five on the west panel. Six of them were placed on the bottom of the panel, to record tension and the remaining three were on the top of the panel recording compressive strain. Three displacement gages were placed along each beam line, one at each support and one at the joint location. The remaining two displacement gages were located at mid-span of the panel, eight inches off each side of the joint (one on the west panel, the other on the east panel). The displacement gage that was directly under the load was moved 12 inches east during the failure test, to prevent damaging the gage. The Gage Layout sheet can be found in the Appendix.

Test Results

Concrete cylinders of the concrete mixes were tested for the precast panels resulting in an average concrete compressive strength of 9 ksi. These values were the average of (3) 4"x8" cylinders tested on April 2, 2013.

The moment capacity of the panel, assuming no joint, was calculated using the 9 ksi concrete compressive strength. According to these calculations the maximum moment in pure bending for the panel is 49.49 kip-ft. The applied moment was 36.32 kip-ft and included the dead load moment as well as the moment due to the maximum applied load. The joint panel was loaded to 73% of the calculated capacity. These calculations can be found in the Appendix.

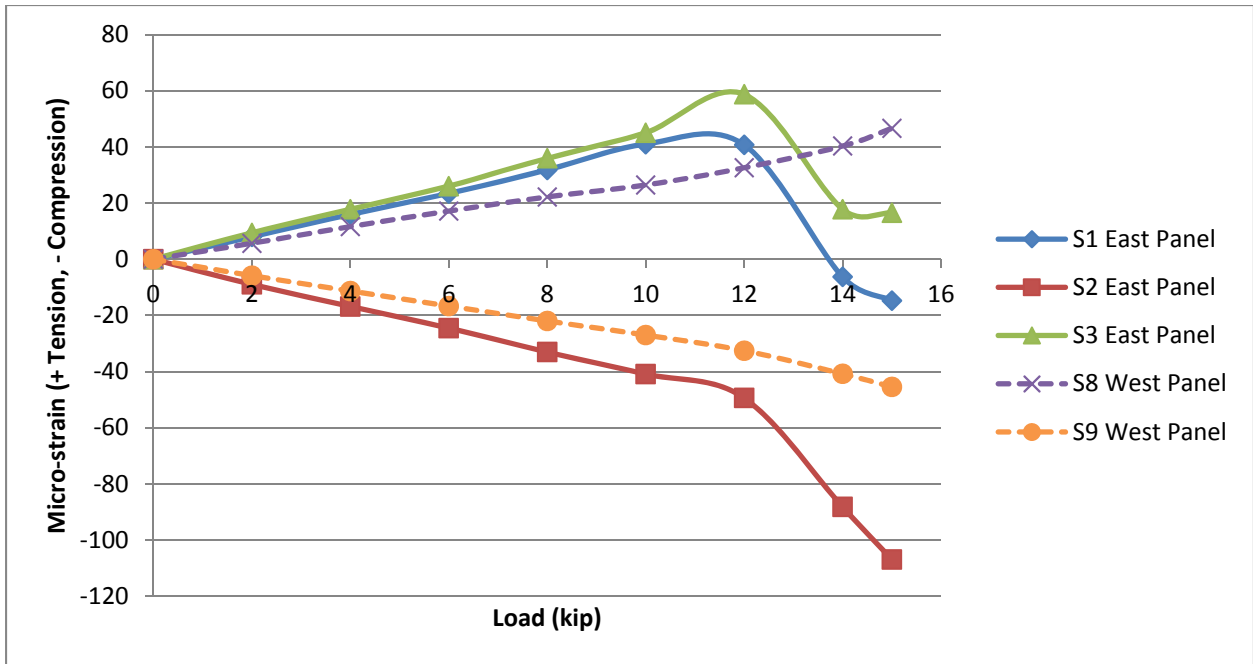

Figure 5 – Strain versus Load Diagram for Static Ramp Test

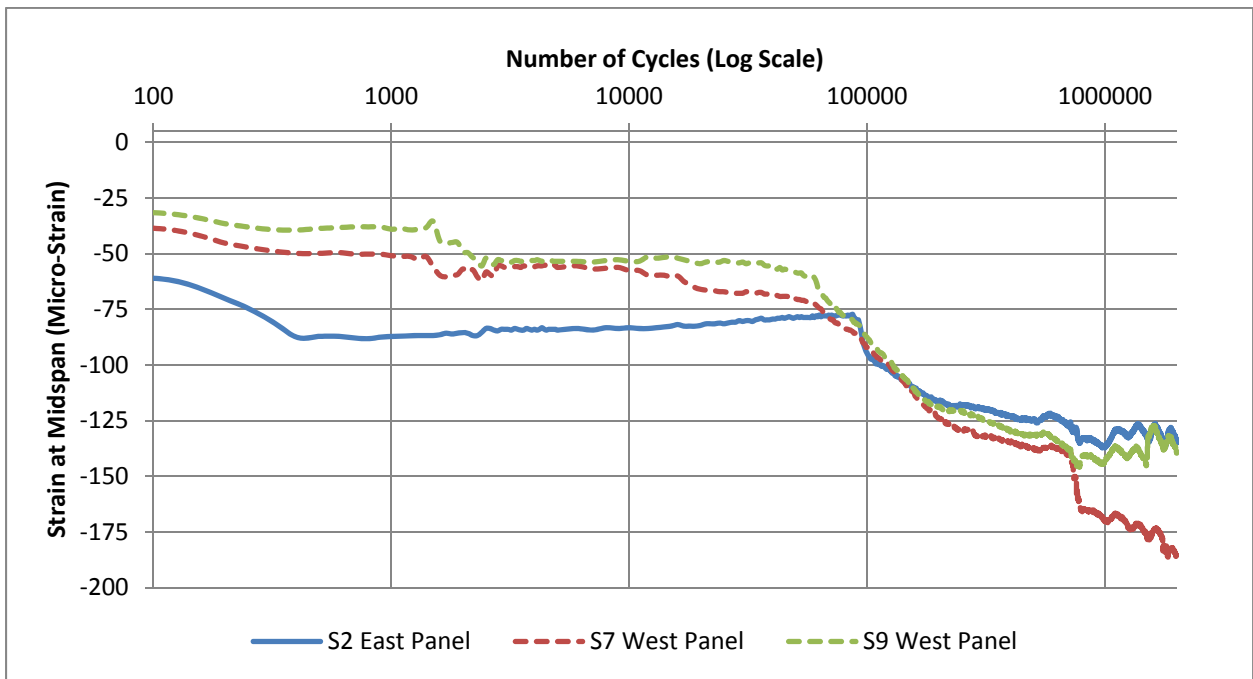

Figure 6 – Continuous Load Test (2 Million Cycles)

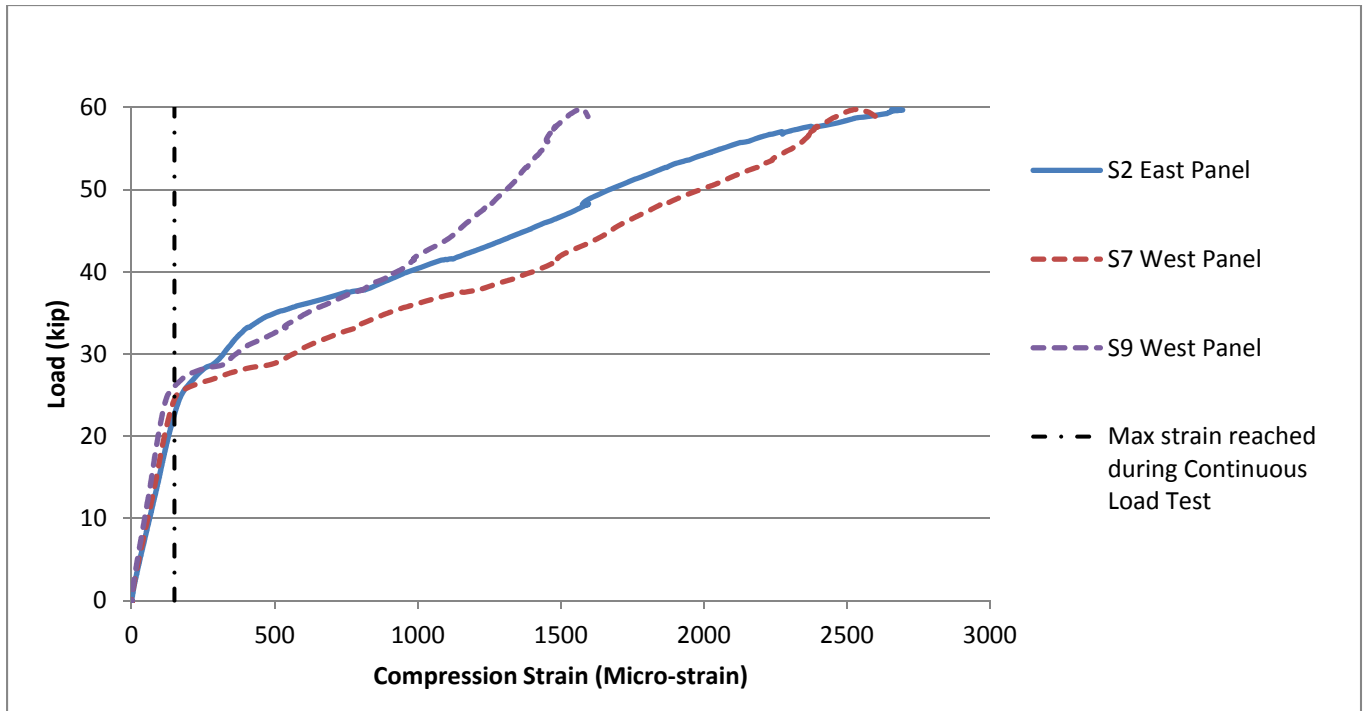

Figure 7 – Load versus Strain Diagram for Failure Test

For the static ramp test, the east panel (loaded panel) cracked at 12 kips. All strain values reached 50 μ strain both compression and tension shown in Figure 5. These results were taken from day one of the static ramp test. The strain gages from day two did not produce good results, due to the existing cracks. The strain values for the cyclic load test started at 50 μ strain and stayed constant for 100,000 cycles. Then the strain increased and steadied at around 150 μ strain. These results are only for the maximum load of 15 kips. A diagonal crack developed after the cyclic load test, on the bottom of the deck, see Figure 11. The failure test results showed a linear relationship for strain versus load until approximately 150 μ strain at 25 kips. From there the strain values exceeded 2500 μ strain at failure. The deck cracked similar to a simply supported beam. At the conclusion of the failure test, compression failure occurred close to the applied load and not at the joint. See Figure 12. The results from gages S2 and S7 plotted in Figure 7 produced very similar values, proving the East and West panels acted as a continuous deck.

During the static test the slab deflected linearly up to an average of 0.05 inches at the 15 kip load. During the cyclic load test, the slab deflected between 0.05 and 0.06 inches for 100,000 cycles. From there the deflection began to increase until it leveled out to between 0.07 and 0.08 inches at two million cycles. The load-displacement relationship for the failure test remained linear until it reached a displacement of 0.08 inches at 25 kips of loading. From there the behavior was ductile reaching an ultimate load of 60 kips with 3 inches of deflection. For all three tests the deflection gage on the east and west panel produced very similar results, again proving the two panels were acting as one continuous deck, with no effect from the joint.

Figures 8 through 10 show the displacement results for the three tests. Figure 8 are results taken from Day 2 of the static ramp test.

Cracks transverse to the joint formed in one deck panel and propagated through the joint and into the other panel. However, no cracking was observed along the joint during testing. Cores were taken along the panel and joint interface to evaluate the bond of the connection. The core sample shown in the Appendix confirmed a good bond between the precast concrete and the epoxy.

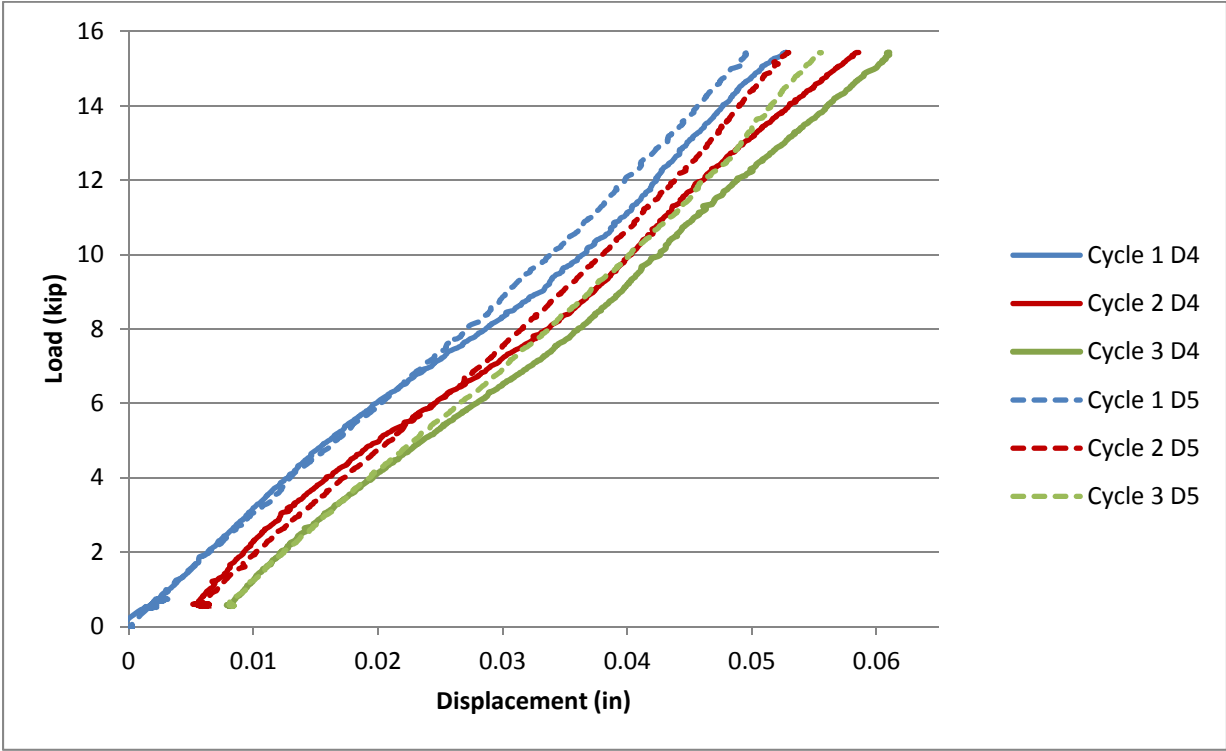

Figure 8 – Load versus Displacement Curve for Static Ramp Test

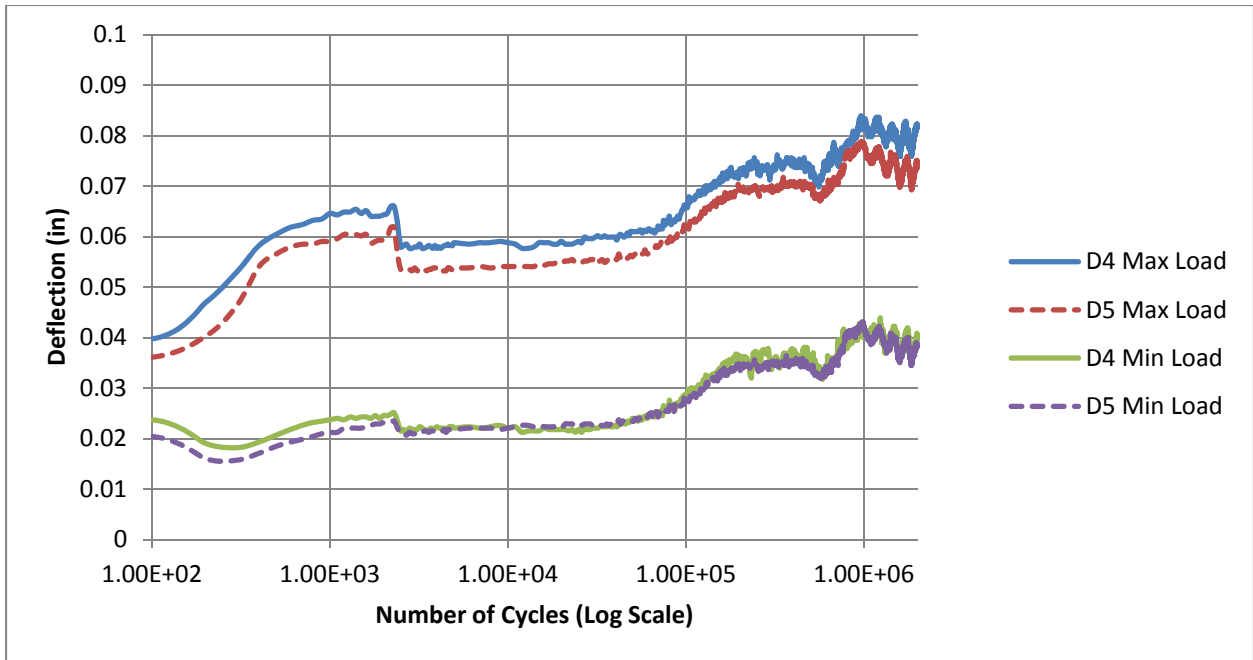

Figure 9 – Continuous Load Test (2 Million Cycles)

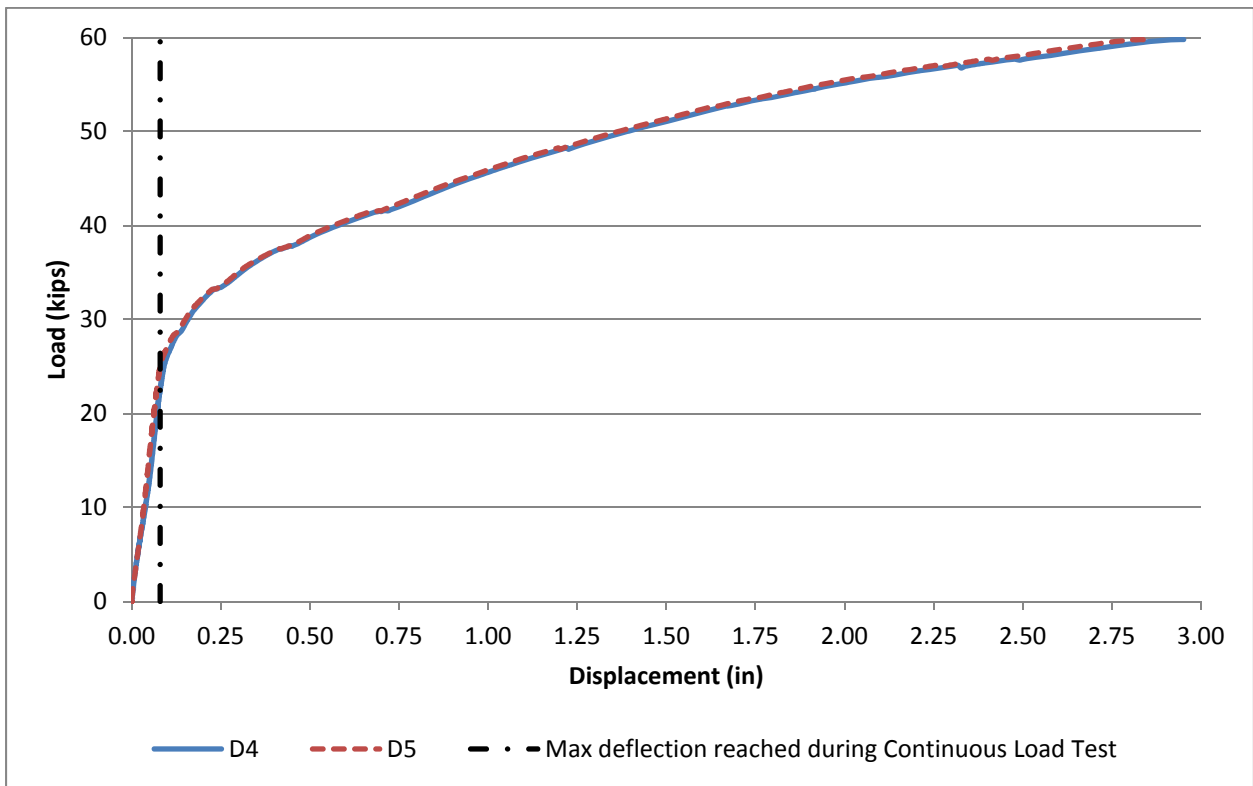

Figure 10 – Load versus Displacement Curve for Failure Test



Figure 11 – Diagonal Crack after Continuous Load Test

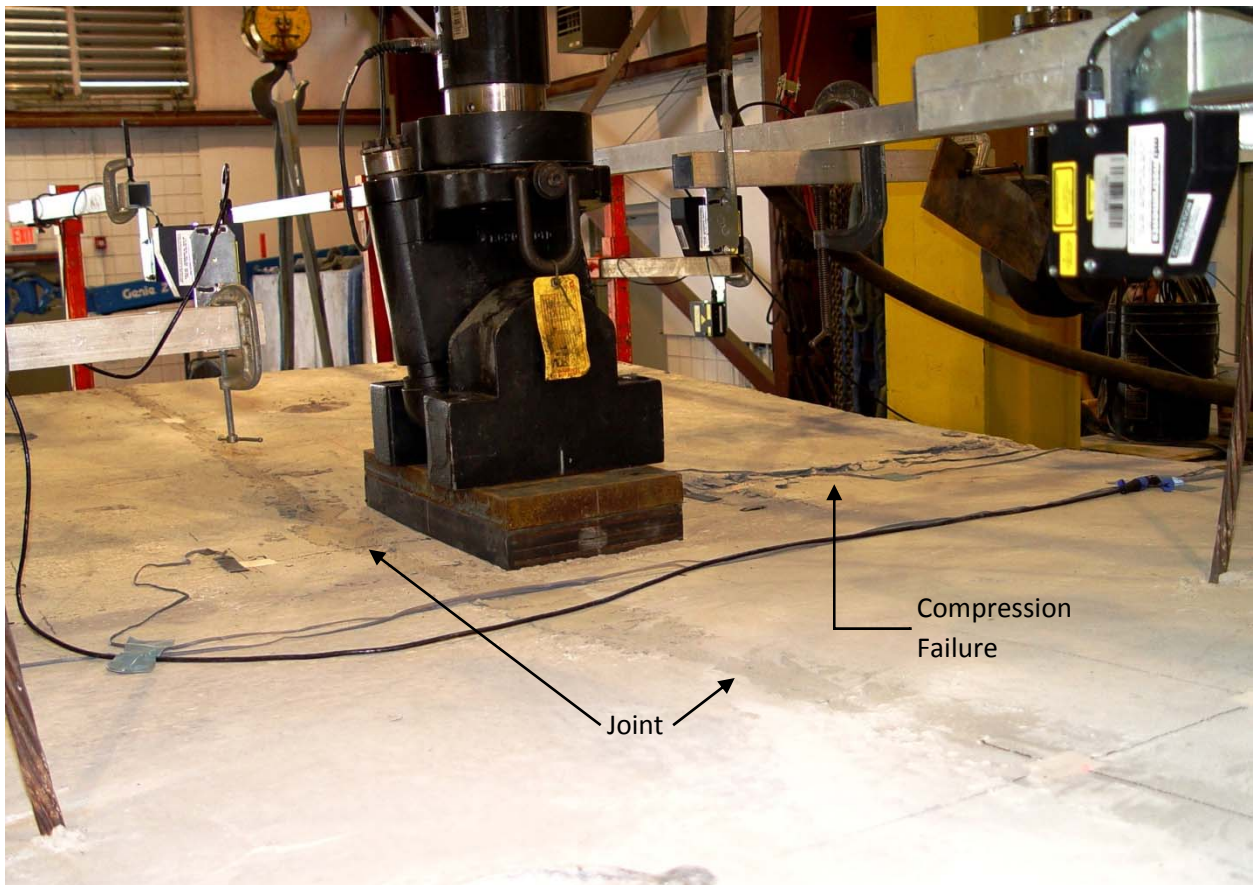

Figure 12 – Failure Test

Conclusion

From these three tests, some preliminary conclusions were made. The first being that connecting the precast panels using the tongue and groove joint with an epoxy resulted in a good bond. The second conclusion was because the displacement values and strain values from the independent panels were so similar; the panels were acting as a continuous deck during loading. This test only used one specimen making it difficult to determine how this joint would compare to deck panel joint connections with lapping reinforcing bars and cast in place concrete. Finally, considering the possible advantages of this construction method, additional research into this connection is recommended.

Appendix

1. Fabrication Drawing & Test Setup
2. Panel Testing Gage Layout
3. Panel Reinforcement Detail
4. Epoxy Compound Specification Sheet
5. Grout Material Specification Sheet
6. Cores
7. Comparison of Strain Gages Used in Tongue and Groove Joint Testing
8. Calculations for Panel Testing

Notes: Place Sika Hi-Mod Gel at joint location for bonding.

A 1/4" joint is called for b/w the panels, however, as tight as possible is recommended.

Use grout for shear pockets and gap b/w panels and steel stringers.

Use a 3/4" stud welded to the stringers as a minimum.

Shear pockets to be cored/cut from the panel and be similar to the dimensions shown in the drawings.

Cylinder Strengths
 Cast Date: 11/23/11
 Test Date: 4/2/13
 1 - 8977 psi
 2 - 9074 psi
 3 - 9097 psi

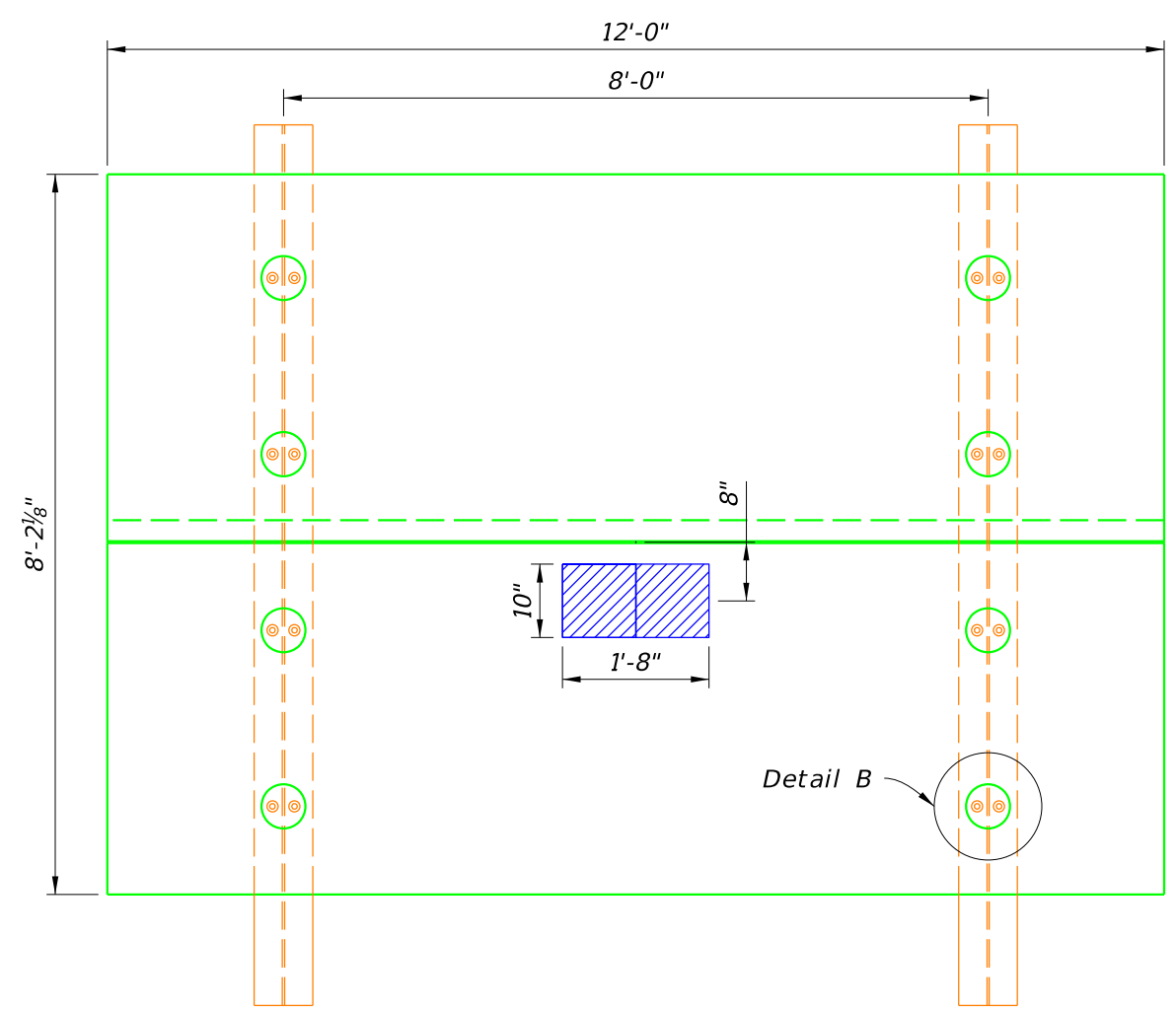

Plan View

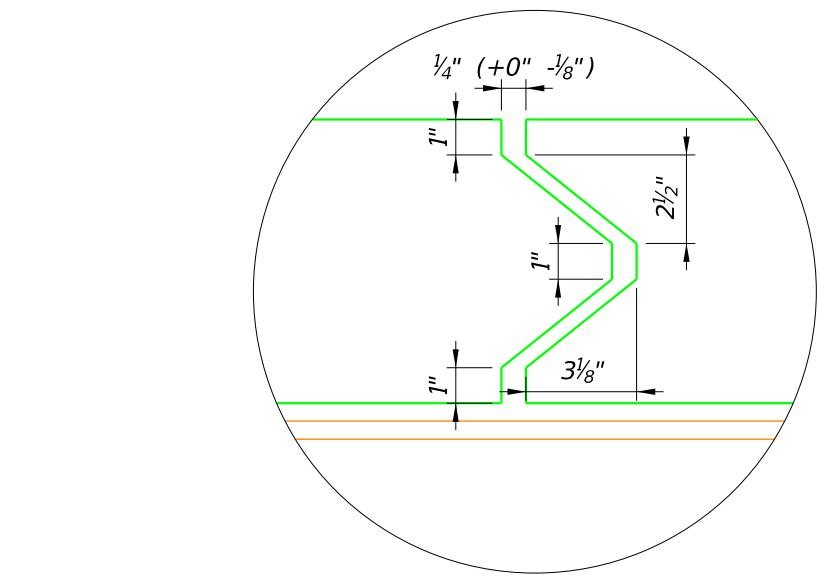

Detail C

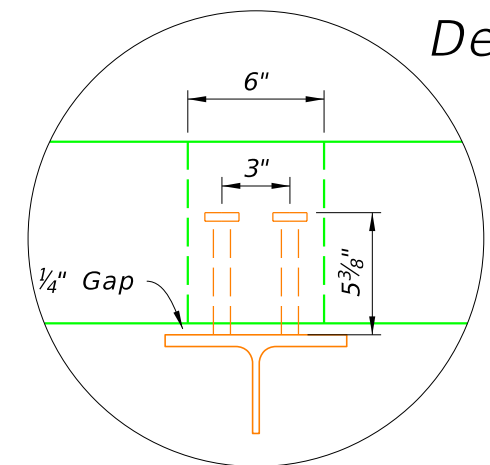

Detail A

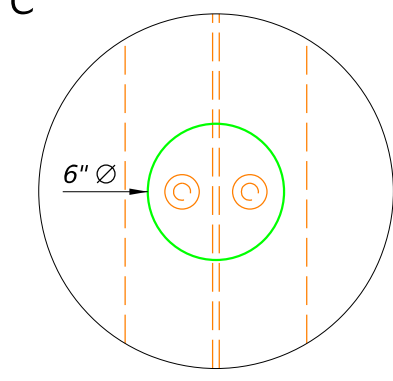

Detail B

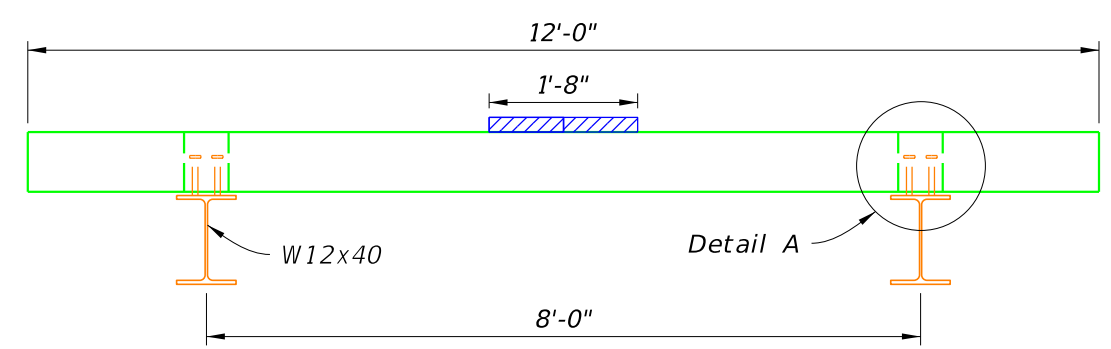

Cross Section

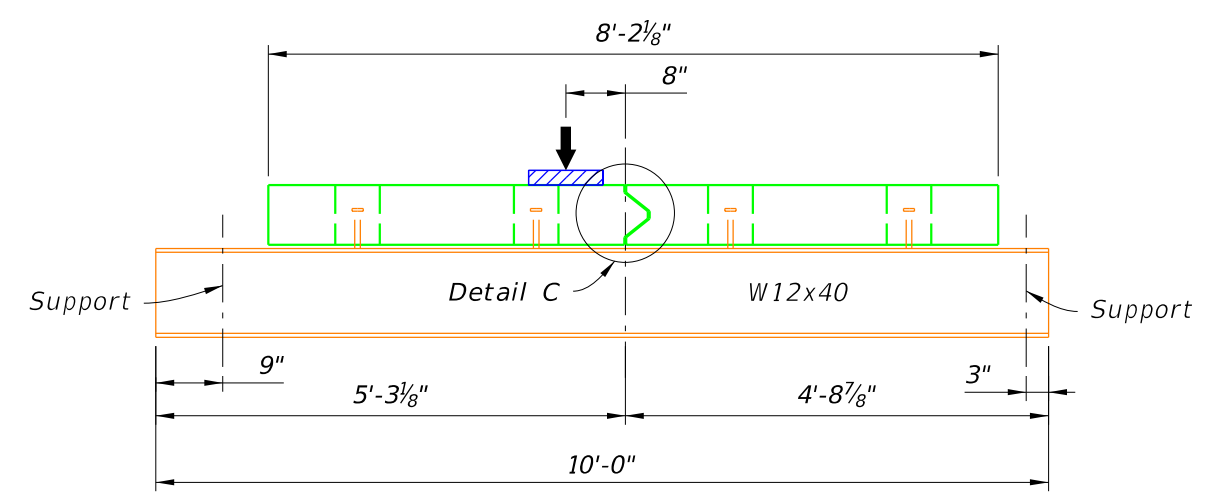

Elevation View

REVISIONS						DRAWN BY: STATE OF FLORIDA DEPARTMENT OF TRANSPORTATION	SHEET TITLE: Fabrication Drawings	PROJECT NAME: Precast Deck Panel V-Groove Connection	REF. DWG. NO.	
DATE	BY	DESCRIPTION	DATE	BY	DESCRIPTION					

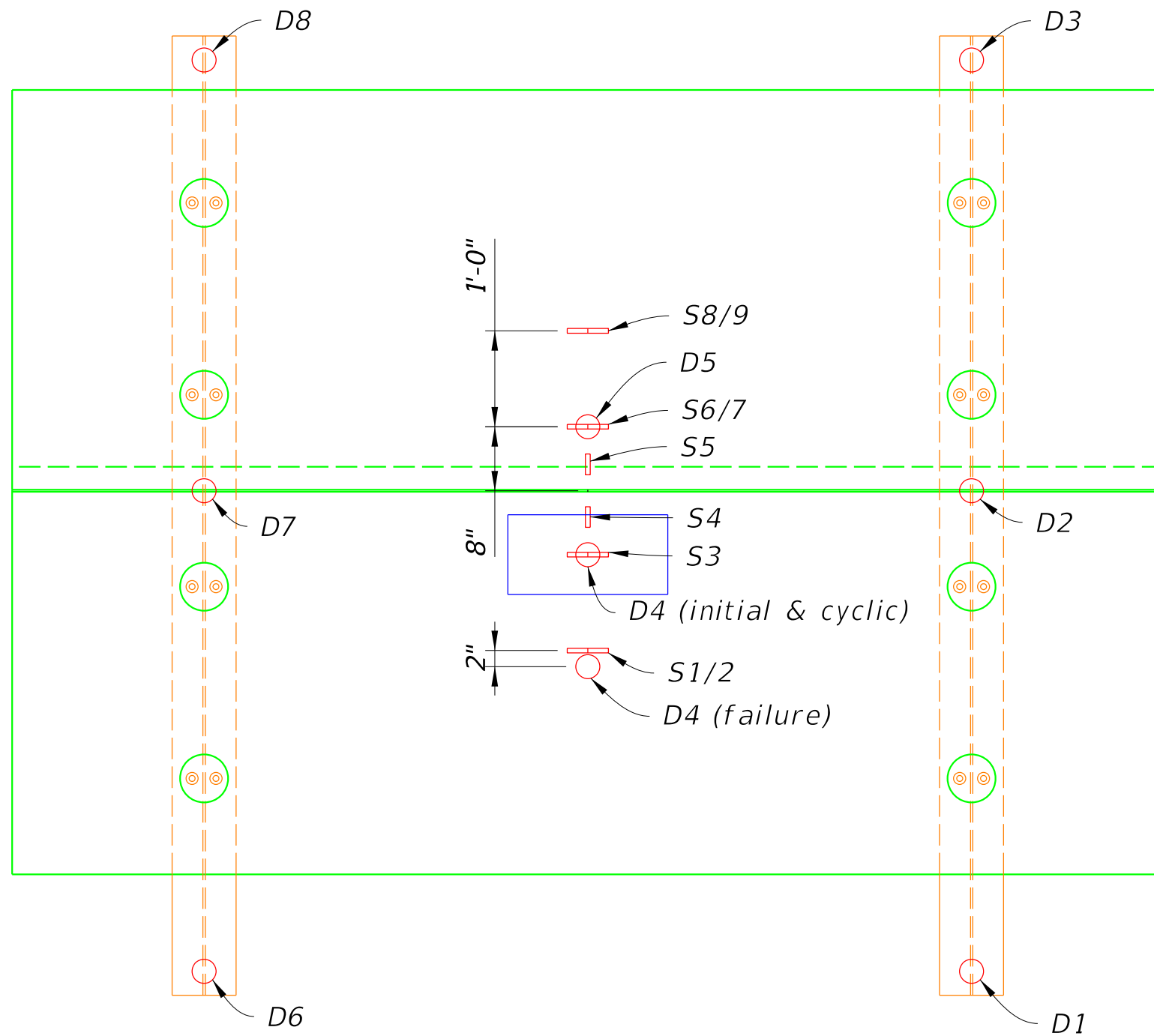
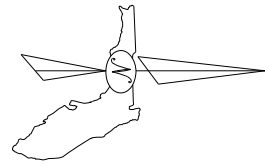

Plan View

Notes:

- D1, D3, D6, and D8 are placed at the supports
- D4 and D5 are placed on the bottom of the deck for the initial static and cyclic testing and on top for the failure testing. D4 was shifted East (down) 2" East of S1/S2 for the failure test.
- D2 and D7 can be placed either top or bottom
- S1, 3, 4, 5, 6, and 8 are placed on the bottom
- S2, 7, and 9 are placed on the top
- S4 and 5 are placed East/West while all other strain gages are placed North/South
- S4 and 5 are placed 2 inches to tip of gage on each side of the transverse joint

REVISIONS						DRAWN BY:	STATE OF FLORIDA DEPARTMENT OF TRANSPORTATION			SHEET TITLE: Gage Layout	REF. DWG. NO.			
DATE	BY	DESCRIPTION	DATE	BY	DESCRIPTION		ROAD NO.	COUNTY	FINANCIAL PROJECT ID					
						CHECKED BY:	PROJECT NAME: Precast Deck Panel V-Groove Connection			SHEET NO. 1				

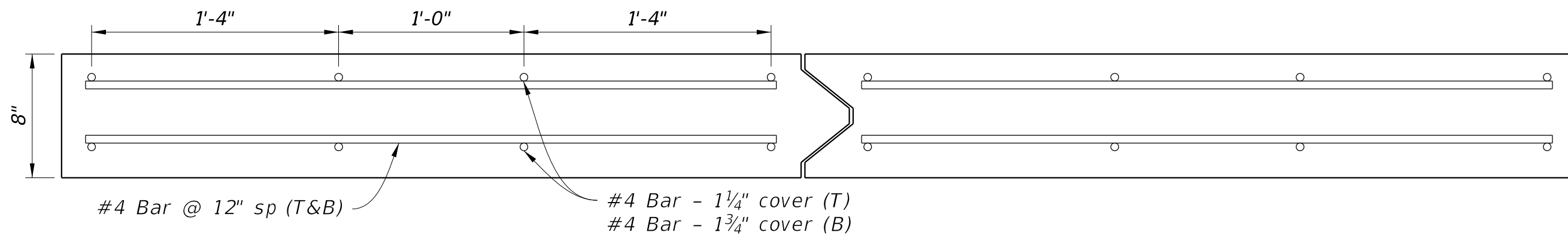

Elevation View

REVISIONS							DRAWN BY:	STATE OF FLORIDA DEPARTMENT OF TRANSPORTATION			SHEET TITLE:	REF. DWG. NO.
DATE	BY	DESCRIPTION	DATE	BY	DESCRIPTION			CHECKED BY:	ROAD NO.	COUNTY		
											Reinforcement Detail	
										Precast Deck Panel T&G Connection		1

Sikadur® 32, Hi-Mod

High-modulus, high-strength, epoxy bonding/grouting adhesive

Description	Sikadur 32, Hi-Mod, is a multi-purpose, 2-component, 100% solids, moisture-tolerant structural epoxy adhesive. It conforms to the current ASTM C-881, Types I, II, and V, Grade-2, Class C and AASHTO M-235 specifications.
Where to Use	<ul style="list-style-type: none"> ■ Bond fresh, plastic concrete to hardened concrete and steel. ■ Grout horizontal cracks in structural concrete and wood by gravity feed. ■ Machinery and 'robotic' base-plate grout. ■ Structural adhesive for concrete, masonry, metal, wood, etc.
Advantages	<ul style="list-style-type: none"> ■ Super-strength bonding/grouting adhesive. ■ Tolerant to moisture before, during and after cure. ■ Excellent adhesion to most structural materials. ■ Convenient easy-to-mix ratio A:B = 1:1 by volume. ■ Easy-to-use for bonding/grouting applications. ■ Fast initial set; rapid gain to ultimate strengths. ■ USDA-certified for use in food plants.
Coverage	<p>Bonding Adhesive - 1 gal. covers approximately 80 sq. ft. on smooth surface.</p> <p>Base Plate Grout - 1 gal. mixed with 1.5 parts oven-dried aggregate by loose volume yields approximately 420 cu. in. of grout.</p> <p>Anchoring grout - 1 gal. yields 231 cu. in. of grout.</p>

Typical Data (Material and curing conditions @ 73°F {23°C} and 50% R.H.)

RESULTS MAY DIFFER BASED UPON STATISTICAL VARIATIONS DEPENDING UPON MIXING METHODS AND EQUIPMENT, TEMPERATURE, APPLICATION METHODS, TEST METHODS, ACTUAL SITE CONDITIONS AND CURING CONDITIONS.

Shelf Life	2 years in original, unopened containers.		
Storage Conditions	Store dry at 40°-95°F (4°-35°C). Condition material to 65°-75°F (18°-24°C) before using.		
Color	Concrete gray		
Mixing Ratio	Component 'A': Component 'B' = 1:1 by volume.		
Viscosity	Approximately 3,000 cps.		
Pot Life	Approximately 30 minutes. (60 gram mass). Approximately 22 minutes. (350 gram mass, 8 oz.)		
Contact Time	40°F (4°C)*: 12 hrs.	73°F (23°C)*: 3-4.5 hrs.	90°F (32°C)*: 1.5-2 hrs
Compressive Modulus, psi	7 day	2.1 X 10 ⁵ psi (1,449 MPa)	
Tensile Properties (ASTM D-638)			
	7 day	Tensile Strength	6,900 psi (48 MPa)
		Elongation at Break	1.9%
	14 day	Modulus of Elasticity	5.4 X 10 ⁵ psi (3,726 MPa)
Flexural Properties (ASTM D-790)			
	14 day	Flexural Strength (Modulus of Rupture)	7,000 psi (48.3 MPa)
		Tangent Modulus of Elasticity in Bending	6.9 X 10 ⁵ psi (4,800 MPa)
Shear Strength (ASTM D-732)	14 day	Shear Strength	6,200 psi (43 MPa)
Water Absorption (ASTM D-570)	7 day	(24 hour immersion)	0.21%
Heat Deflection Temperature (ASTM D-648)			
	7 day	[fiber stress loading 264 psi (1.8 MPa)]	122°F (50°C)
Bond Strength (ASTM C-882):			
	2 day (moist cure)	Plastic Concrete to Hardened Concrete	1,700 psi (11.7 MPa)
		Hardened Concrete to Hardened Concrete	2,000 psi (13.8 MPa)
		Hardened Concrete to Steel	1,900 psi (13.1 MPa)
	14 day (moist cure)	Plastic Concrete to Hardened Concrete	2,200 psi (15.1 MPa)
		Plastic Concrete to Steel	2,000 psi (13.8 MPa)
		Hardened Concrete to Hardened Concrete	2,000 psi (13.8 MPa)

Compressive Properties (ASTM D-695)

Compressive Strength, psi (MPa)		40°F* (4°C)	73°F* (23°C)	90°F* (32°C)
8 hour		-	140 (1.0)	1,700 (11.7)
16 hour		-	4,800 (33.1)	7,300 (50.3)
1 day		30.0 (0.2)	5,700 (39.3)	7,300 (50.3)
3 day		5,300 (36.6)	11,300 (77.9)	10,400(71.7)
7 day		9,600 (66.2)	11,800 (81.4)	10,400(71.7)
14 day		11,900 (82.1)	12,200 (84.1)	10,400(71.7)
28 day		12,600 (86.9)	12,200 (84.1)	10,500(72.4)

*Material cured and tested at the temperatures indicated.



Packaging	1, 2 and 4 gal. units.
How to Use	Surface must be clean and sound. It may be dry or damp, but free of standing water. Remove dust,
Surface Preparation	laitance, grease, curing compounds, impregnations, waxes and any other contaminants. Preparation Work: Concrete - Should be cleaned and prepared to achieve a laitance and contaminant free, open textured surface by blastcleaning or other equivalent mechanical means. Steel - Should be cleaned and prepared thoroughly by blastcleaning.
Mixing	Pre-mix each component. Proportion equal parts by volume of Component 'A' and Component 'B' into clean pail. Mix thoroughly for 3 minutes with Sika paddle on low-speed (400-600 rpm) drill until blend is a uniform color. Mix only that quantity that can be applied within its pot life.
Application	To bond fresh concrete to hardened concrete - Apply by brush, roller, broom or spray. Place fresh concrete while Sikadur 32, Hi-Mod, is still tacky. If coating becomes glossy and loses tackiness, remove any surface contaminants then recoat with additional Sikadur 32 Hi-Mod, and proceed. To grout baseplates - Add up to 1 1/2 parts of oven-dried aggregate to 1 part of mixed Sikadur 32, Hi-Mod, by volume. Place grout under baseplate. Avoid contact with the underside of the plate. A 1/4 to 3/8 in. (6 to 10 mm) space should remain between the top of the grout and the bottom of the plate. Maximum thickness of grout per lift is 1.5 in. (38 mm) If multiple lifts are needed, allow preceding layer to cool to touch before applying additional layer. The remaining 1/4 to 3/8 in. (6 to 10 mm) space should be filled with neat Sikadur 32 Hi-Mod. Pour a sufficient quantity of neat epoxy to allow the level to rise slightly higher than the underside of the bearing plate. To gravity feed cracks - Pour neat material into vee-notched crack. Continue placement until completely filled. Seal underside of slab prior to filling if cracks reflect through.
Limitations	<ul style="list-style-type: none"> ■ Minimum substrate and ambient temperature 40°F (4°C). ■ For spray applications, consult Technical Service at 800-933-7452. ■ Use only oven-dry aggregate. ■ Material is a vapor barrier after cure. ■ For applications on exterior, on-grade substrates, consult Technical Services at 800-933-7452. ■ Do not apply over wet, glistening surface. ■ Not an aesthetic product. Color may alter due to variations in lighting and/or UV exposure.
Warning	Component 'A' - IRRITANT; SENSITIZER - Contains epoxy resin, nonyl phenol. Can cause skin sensitization after prolonged or repeated contact. Eye irritant. May cause respiratory irritation. Harmful if swallowed. Component 'B' - CORROSIVE; IRRITANT; SENSITIZER - Contains amines, silica (quartz), and benzylalcohol nonyl phenol. Contact with eyes or skin causes severe burns. Can cause skin sensitization after prolonged or repeated contact. Skin/respiratory/eye irritant. Harmful if swallowed. Deliberate concentration of vapors of Component A or B for purposes of inhalation is harmful and can be fatal. Cured material, if sanded, may result in exposure to a chemical known to the state of California to cause cancer.
First Aid	Eyes: Hold eyelids apart and flush thoroughly with water for 15 minutes. Skin: Remove contaminated clothing. Wash skin thoroughly for 15 minutes with soap and water. Inhalation: Remove person to fresh air. Ingestion: Do not induce vomiting. In all cases, contact a physician immediately if symptoms persist.
Clean Up	Wear chemical resistant gloves/goggles/clothing. Ventilate area. In absence of adequate general and local exhaust ventilation, use a properly filled NIOSH respirator. Confine spill. Collect with absorbent material. Dispose of in accordance with current, applicable local, state and federal regulations. Uncured material can be removed with solvent. Strictly follow manufacturer's warnings and instructions for use. Cured material can only be removed mechanically.
Handling & Storage	Avoid direct contact with skin and eyes. Wear chemical resistant gloves/goggles/clothing. Use only with adequate ventilation. In absence of adequate general and local exhaust ventilation, use a properly filled NIOSH respirator. Wash thoroughly after handling product. Launder clothing before reuse. Store in a cool dry well ventilated area.

KEEP CONTAINER TIGHTLY CLOSED • KEEP OUT OF REACH OF CHILDREN • NOT FOR INTERNAL CONSUMPTION • FOR INDUSTRIAL USE ONLY
All information provided by Sika Corporation ("Sika") concerning Sika products, including but not limited to, any recommendations and advice relating to the application and use of Sika products, is given in good faith based on Sika's current experience and knowledge of its products when properly stored, handled and applied under normal conditions in accordance with Sika's instructions. In practice, the differences in materials, substrates, storage and handling conditions, actual site conditions and other factors outside of Sika's control are such that Sika assumes no liability for the provision of such information, advice, recommendations or instructions related to its products, nor shall any legal relationship be created by or arise from the provision of such information, advice, recommendations or instructions related to its products. The user of the Sika product(s) must test the product(s) for suitability for the intended application and purpose before proceeding with the full application of the product(s). Sika reserves the right to change the properties of its products without notice. All sales of Sika product(s) are subject to its current terms and conditions of sale which are available at www.sikausa.com or by calling 800-933-7452.

Prior to each use of any Sika product, the user must always read and follow the warnings and instructions on the product's most current Technical Data Sheet, product label and Material Safety Data Sheet which are available online at www.sikausa.com or by calling Sika's Technical Service Department at 800-933-7452. Nothing contained in any Sika materials relieves the user of the obligation to read and follow the warnings and instruction for each Sika product as set forth in the current Technical Data Sheet, product label and Material Safety Data Sheet prior to product use.

LIMITED WARRANTY: Sika warrants this product for one year from date of installation to be free from manufacturing defects and to meet the technical properties on the current Technical Data Sheet if used as directed within shelf life. User determines suitability of product for intended use and assumes all risks. Buyer's sole remedy shall be limited to the purchase price or replacement of product exclusive of labor or cost of labor. **NO OTHER WARRANTIES EXPRESS OR IMPLIED SHALL APPLY INCLUDING ANY WARRANTY OF MERCHANTABILITY OR FITNESS FOR A PARTICULAR PURPOSE. SIKASHALL NOT BELIEVABLE UNDER ANY LEGAL THEORY FOR SPECIAL OR CONSEQUENTIAL DAMAGES. SIKASHALL NOT BE RESPONSIBLE FOR THE USE OF THIS PRODUCT IN A MANNER TO INFRINGE ON ANY PATENT OR ANY OTHER INTELLECTUAL PROPERTY RIGHTS HELD BY OTHERS.**

Visit our website at www.sikausa.com

1-800-933-SIKA NATIONWIDE

Regional Information and Sales Centers. For the location of your nearest Sika sales office, contact your regional center.

Sika Corporation
201 Polito Avenue
Lyndhurst, NJ 07071
Phone: 800-933-7452
Fax: 201-933-6225

Sika Canada Inc.
601 Delmar Avenue
Pointe Claire
Quebec H9R 4A9
Phone: 514-697-2610
Fax: 514-694-2792

Sika Mexicana S.A. de C.V.
Carretera Libre Celaya Km. 8.5
Fracc. Industrial Balvanera
Corregidora, Queretaro
C.P. 76920
Phone: 52 442 2385800
Fax: 52 442 2250537



Sika and Sikadur are registered trademarks. Printed in Canada.

PRODUCT DATA

3 03 62 13 Non-Metallic
Non-Shrink Grouting

MASTERFLOW® 928

High-precision mineral-aggregate grout with extended working time

Description

Masterflow® 928 grout is a hydraulic cement-based mineral-aggregate grout with an extended working time. It is ideally suited for grouting machines or plates requiring precision load-bearing support. It can be placed from fluid to damp pack over a temperature range of 45 to 90° F (7 to 32° C). Masterflow® 928 grout meets the requirements of ASTM C1107 and US Army Corps of Engineers CRD C621 (ASTM C1107-91a, Grades B and C), at a fluid consistency over a 30-minute working time and ANSI/NSF 61 approved. Suitable for use with potable water.

Yield

One 55 lb (25 kg) bag of Masterflow® 928 grout mixed with approximately 10.5 lbs (4.8 kg) or 1.26 gallons (4.8 L) of water, yields approximately 0.50 ft³ (0.014 m³) of grout.

The water requirement may vary due to mixing efficiency, temperature, and other variables.

Packaging

55 lb (25 kg) multi-wall paper bags
3,300 lb (1,500 kg) bulk bags

Shelf Life

1 year when properly stored

Storage

Store in unopened bags in clean, dry conditions.

Features

- Extended working time
- Can be mixed at a wide range of consistencies
- Freeze/thaw resistant
- Hardens free of bleeding, segregation, or settlement shrinkage
- Contains high-quality, well-graded quartz aggregate
- Sulfate resistant
- ANSI / NSF 61 approved

Benefits

- Ensures sufficient time for placement
- Ensures proper placement under a variety of conditions
- Suitable for exterior applications
- Provides a maximum effective bearing area for optimum load transfer
- Provides optimum strength and workability
- For marine, wastewater, and other sulfate-containing environments
- Suitable for use with potable water

Where to Use

INDUSTRIES

- Power generation
- Pulp and paper mills
- Steel and cement mills
- Stamping and machining
- Water and waste treatment
- General construction

APPLICATIONS

- Where a nonshrink grout is required for maximum effective bearing area for optimum load transfer
- Where high one-day and later-age compressive strengths are required
- Applications requiring a pumpable grout
- Compressors and generators
- Pump bases and drive motors
- Tank bases
- Conveyors
- Grouting anchor bolts, rebar and dowel rods
- Nonshrink grouting of precast well panels, beams, columns, curtain walls, concrete systems and other structural and non-structural building components
- Repairing concrete, including grouting voids and rock pockets

LOCATIONS

- Interior or exterior
- Marine applications
- Freeze/thaw environments

How to Apply

Surface Preparation

1. Steel surfaces must be free of dirt, oil, grease, or other contaminants.
2. The surface to be grouted must be clean, SSD, strong, and roughened to a CSP of 5 – 9 following ICRI Guideline 03732 to permit proper bond. For freshly placed concrete, consider using Liquid Surface Etchant (see Form No. 1020198) to achieve the required surface profile.
3. When dynamic, shear or tensile forces are anticipated, concrete surfaces should be chipped with a "chisel-point" hammer, to a roughness of (plus or minus) 3/8" (10 mm). Verify the absence of bruising following ICRI Guideline 03732.
4. Concrete surfaces should be saturated (ponded) with clean water for 24 hours just before grouting.
5. All freestanding water must be removed from the foundation and bolt holes immediately before grouting.



Technical Data

Composition

Masterflow® 928 is a hydraulic cement-based mineral-aggregate grout.

Compliances

- ASTM C1107 US Army Corps of Engineers CRD C621 (ASTM C1107-93a, Grades B and C), requirements at a fluid consistency over a temperature range of 45 to 90° F (7 to 32° C)
- City of Los Angeles Research Report Number RR 23137
- ANSI / NSF 61 for use with potable water

Test Data

PROPERTY	RESULTS			TEST METHODS
Compressive strengths, psi (MPa)				ASTM C 942, according to ASTM C 1107
	Plastic¹	Consistency Flowable²	Fluid³	
1 day	4,500 (31)	4,000 (28)	3,500 (24)	
3 days	6,000 (41)	5,000 (34)	4,500 (31)	
7 days	7,500 (52)	6,700 (46)	6,500 (45)	
28 days	9,000 (62)	8,000 (55)	7,500 (52)	
Volume change*				ASTM C 1090
	% Change	% Requirement of ASTM C 1107		
1 day	> 0	0.0 – 0.30		
3 days	0.04	0.0 – 0.30		
14 days	0.05	0.0 – 0.30		
28 days	0.06	0.0 – 0.30		
Setting time, hr:min				ASTM C 191
	Plastic¹	Consistency Flowable²	Fluid³	
Initial set	2:30	3:00	4:30	
Final set	4:00	5:00	6:00	
Flexural strength,* psi (MPa)				ASTM C 78
3 days	1,000 (6.9)			
7 days	1,050 (7.2)			
28 days	1,150 (7.9)			
Modulus of elasticity,* psi (MPa)				ASTM C 469, modified
3 days	2.82 x 10 ⁶ (1.94 x 10 ⁴)			
7 days	3.02 x 10 ⁶ (2.08 x 10 ⁴)			
28 days	3.24 x 10 ⁶ (2.23 x 10 ⁴)			
Coefficient of thermal expansion,* in/in/° F (mm/mm/° C)	6.5 x 10 ⁻⁶ (11.7 x 10 ⁻⁶)			ASTM C 531
Split tensile and tensile strength,* psi (MPa)				ASTM C 496 (splitting tensile) ASTM C 190 (tensile)
	Splitting Tensile	Tensile		
3 days	575 (4.0)	490 (3.4)		
7 days	630 (4.3)	500 (3.4)		
28 days	675 (4.7)	500 (3.4)		
Punching shear strength,* psi (MPa), 3 by 3 by 11" (76 by 76 by 279 mm) beam				BASF Method
3 days	2,200 (15.2)			
7 days	2,260 (15.6)			
28 days	2,650 (18.3)			
Resistance to rapid freezing and thawing	300 Cycles RDF 99%			ASTM C 666, Procedure A

¹100 – 125% flow on flow table per ASTM C 230

²125 – 145% flow on flow table per ASTM C 230

³25 to 30 seconds through flow cone per ASTM C 939

*Test conducted at a fluid consistency

Test results are averages obtained under laboratory conditions. Expect reasonable variations.

Test Data, continued

PROPERTY		RESULTS	TEST METHODS
Ultimate tensile strength and bond stress			ASTM E 488, tests*
Diameter in (mm)	Depth in (mm)	Tensile strength lbs (kg)	Bond stress psi (MPa)
5/8 (15.9)	4 (101.6)	23,500 (10,575)	2,991 (20.3)
3/4 (19.1)	5 (127.0)	30,900 (13,905)	2,623 (18.1)
1 (25.4)	6.75 (171.5)	65,500 (29,475)	3,090 (21.3)

*Average of 5 tests in 4,000 psi (27.6 MPa) concrete using 125 ksi threaded rod in 2" (51mm) diameter, damp, core-drilled holes.

Notes:

1. Grout was mixed to a fluid consistency.
2. Recommended design stress: 2,275 psi (15.7 MPa).
3. Refer to the "Adhesive and Grouted Fastener Capacity Design Guidelines" for more detailed information.
4. Tensile tests with headed fasteners were governed by concrete failure.

Jobsite Testing

If strength tests must be made at the jobsite, use 2" (51 mm) metal cube molds as specified by ASTM C 942 and ASTM C 1107. DO NOT use cylinder molds. Control field and laboratory tests on the basis of desired placement consistency rather than strictly on water content.

6. Anchor bolt holes must be grouted and sufficiently set before the major portion of the grout is placed.

7. Shade the foundation from sunlight 24 hours before and 24 hours after grouting.

Forming

1. Forms should be liquid tight and nonabsorbent. Seal forms with putty, sealant, caulk, polyurethane foam.

2. Moderately sized equipment should utilize a head form sloped at 45 degrees to enhance the grout placement. A moveable head box may provide additional head at minimum cost.

3. Side and end forms should be a minimum 1" (25 mm) distant horizontally from the object grouted to permit expulsion of air and any remaining saturation water as the grout is placed.

4. Leave a minimum of 2" between the bearing plate and the form to allow for ease of placement.

5. Use sufficient bracing to prevent the grout from leaking or moving.

6. Eliminate large, nonsupported grout areas wherever possible.

7. Extend forms a minimum of 1" (25 mm) higher than the bottom of the equipment being grouted.

8. Expansion joints may be necessary for both indoor and outdoor installation. Consult your local BASF field representative for suggestions and recommendations.

Temperature

1. For precision grouting, store and mix grout to produce the desired mixed-grout temperature. If bagged material is hot, use cold water, and if bagged material is cold, use warm water to achieve a mixed-product temperature as close to 70° F (21°C) as possible.

Recommended Temperature Guidelines for Precision Grouting

	MINIMUM ° F (° C)	PREFERRED ° F (° C)	MAXIMUM ° F (° C)
Foundation and plates	45 (7)	50 – 80 (10 – 27)	90 (32)
Mixing water	45 (7)	50 – 80 (10 – 27)	90 (32)
Grout at mixed and placed temp	45 (7)	50 – 80 (10 – 27)	90 (32)

2. If temperature extremes are anticipated or special placement procedures are planned, contact your local BASF representative for assistance.

3. When grouting at minimum temperatures, see that the foundation, plate, and grout temperatures do not fall below 40° F (7° C) until after final set. Protect the grout from freezing (32° F or 0° C) until it has attained a compressive strength of 3,000 psi (21 MPa).

Mixing

1. Add the minimum potable or ASTM C1602-compliant water to the mixer, then slowly add the Masterflow 928, while mixing.

2. Masterflow 928 water requirements depend on the desired consistency, mixing efficiency, material and ambient temperature conditions. Begin with the minimum water listed (See table below), and gradually add additional water while mixing until the desired placement consistency is reached.

Consistency	Test Method	Results	Minimum Water per Bag
Plastic	ASTM C230	100-125%	6.0 lbs
Flowable	ASTM C230	125-145%	8.0 lbs
Fluid	ASTM C939	25-30 sec	9.0 lbs

3. Do not use water in an amount or at a temperature that will produce an ASTM C939 initial flow of less than 25 seconds, or cause mixed grout to bleed or segregate.

4. Moderately sized batches of grout are best mixed in one or more clean mortar mixers. For large batches, use ready-mix trucks and 3,300 lb (1,500 kg) bags for maximum efficiency and economy.

5. Mix grout a minimum of 5 minutes after all material and water is in the mixer. Use mechanical mixer only.

6. Do not mix more grout than can be placed in approximately 30 minutes.

7. Transport by wheelbarrow or buckets or pump to the equipment being grouted. Minimize the transporting distance.

8. Do not retemper grout by adding water and remixing after it stiffens.

9. DO NOT VIBRATE GROUT TO FACILITATE PLACEMENT.

10. For aggregate extension guidelines, refer to Appendix MB-10: Guide to Cementitious Grouting.

Application

1. Always place grout from only one side of the equipment to prevent air or water entrapment beneath the equipment. Place Masterflow® 928 in a continuous pour. Discard grout that becomes unworkable. Make sure that the material fills the entire space being grouted and that it remains in contact with plate throughout the grouting process.
2. Immediately after placement, trim the surfaces with a trowel and cover the exposed grout with clean wet rags (not burlap). Keep rags moist until grout surface is ready for finishing or until final set.
3. The grout should offer stiff resistance to penetration with a pointed mason's trowel before the grout forms are removed or excessive grout is cut back. After removing the damp rags, immediately coat with a recommended curing compound compliant with ASTM C 309 or preferably ASTM C 1315.
4. Do not vibrate grout. Use steel straps inserted under the plate to help move the grout.
5. Consult your BASF representative before placing lifts more than 6" (152 mm) in depth.

Curing

Cure all exposed grout with an approved membrane curing compound compliant with ASTM C 309 or preferably ASTM C 1315. Apply curing compound immediately after the wet rags are removed to minimize potential moisture loss.

For Best Performance

- For guidelines on specific anchor-bolt applications, contact BASF Technical Service.
- Do not add plasticizers, accelerators, retarders, or other additives unless advised in writing by BASF Technical Service.
- The water requirement may vary with mixing efficiency, temperature, and other variables.
- Hold a pre-job conference with your local representative to plan the installation. Hold conferences as early as possible before the installation of equipment, sole plates, or rail

mounts. Conferences are important for applying the recommendations in this product data sheet to a given project, and they help ensure a placement of highest quality and lowest cost.

- The ambient and initial temperature of the grout should be in the range of 45 to 90° F (7 to 32° C) for both mixing and placing. Ideally the amount of mixing water used should be that which is necessary to achieve a 25 – 30 second flow according to ASTM C 939 (CRD C 611). For placement outside of the 45 to 90° F (7 to 32° C) range, contact your local BASF representative.
- For pours greater than 6" (152 mm) deep, consult your local BASF representative for special precautions and installation procedures.
- Use Embecco® 885 grout for dynamic load-bearing support and similar application conditions as Masterflow® 928.
- Use Masterflow® 816, Masterflow® 1205, or Masterflow® 1341 post-tensioning cable grouts when the grout will be in contact with steel stressed over 80,000 psi (552 MPa).
- Masterflow® 928 is not intended for use as a floor topping or in large areas with exposed shoulders around baseplates. Where grout has exposed shoulders, occasional hairline cracks may occur. Cracks may also occur near sharp corners of the baseplate and at anchor bolts. These superficial cracks are usually caused by temperature and moisture changes that affect the grout at exposed shoulders at a faster rate than the grout beneath the baseplate. They do not affect the structural, nonshrink, or vertical support provided by the grout if the foundation-preparation, placing, and curing procedures are properly carried out.
- The minimum placement depth is 1" (25 mm).
- Make certain the most current versions of product data sheet and MSDS are being used; call Customer Service (1-800-433-9517) to verify the most current version.
- Proper application is the responsibility of the user. Field visits by BASF personnel are for the purpose of making technical recommendations only and not for supervising or providing quality control on the jobsite.

Health and Safety

MASTERFLOW® 928

WARNING!

Masterflow® 928 contains silica, crystalline quartz; portland cement; limestone; calcium oxide; gypsum; silica, amorphous; magnesium oxide.

Risks

Product is alkaline on contact with water and may cause injury to skin or eyes. Ingestion or inhalation of dust may cause irritation. Contains small amount of free respirable quartz which has been listed as a suspected human carcinogen by NTP and IARC. Repeated or prolonged overexposure to free respirable quartz may cause silicosis or other serious and delayed lung injury.

Precautions

Avoid contact with skin, eyes and clothing. Prevent inhalation of dust. Wash thoroughly after handling. Keep container closed when not in use. DO NOT take internally. Use only with adequate ventilation. Use impervious gloves, eye protection and if the TLV is exceeded or used in a poorly ventilated area, use NIOSH/MSHA approved respiratory protection in accordance with applicable Federal, state and local regulations.

First Aid

In case of eye contact, flush thoroughly with water for at least 15 minutes. In case of skin contact, wash affected areas with soap and water. If irritation persists, SEEK MEDICAL ATTENTION. Remove and wash contaminated clothing. If inhalation causes physical discomfort, remove to fresh air. If discomfort persists or any breathing difficulty occurs or if swallowed, SEEK IMMEDIATE MEDICAL ATTENTION.

Waste Disposal Method

This product when discarded or disposed of, is not listed as a hazardous waste in federal regulations. Dispose of in a landfill in accordance with local regulations.

For additional information on personal protective equipment, first aid, and emergency procedures, refer to the product Material Safety Data Sheet (MSDS) on the job site or contact the company at the address or phone numbers given below.

Proposition 65

This product contains material listed by the State of California as known to cause cancer, birth defects or other reproductive harm.

VOC Content

0 g/L or 0 lbs/gal less water and exempt solvents.

**For medical emergencies only,
call ChemTrec (1-800-424-9300).**

BASF Construction Chemicals, LLC – Building Systems

889 Valley Park Drive
Shakopee, MN, 55379

www.BuildingSystems.BASF.com

Customer Service 800-433-9517

Technical Service 800-243-6739



LIMITED WARRANTY NOTICE Every reasonable effort is made to apply BASF exacting standards both in the manufacture of our products and in the information which we issue concerning these products and their use. We warrant our products to be of good quality and will replace or, at our election, refund the purchase price of any products proved defective. Satisfactory results depend not only upon quality products, but also upon many factors beyond our control. Therefore, except for such replacement or refund, BASF MAKES NO WARRANTY OR GUARANTEE, EXPRESS OR IMPLIED, INCLUDING WARRANTIES OF FITNESS FOR A PARTICULAR PURPOSE OR MERCHANTABILITY, RESPECTING ITS PRODUCTS, and BASF shall have no other liability with respect thereto. Any claim regarding product defect must be received in writing within one (1) year from the date of shipment. No claim will be considered without such written notice or after the specified time interval. User shall determine the suitability of the products for the intended use and assume all risks and liability in connection therewith. Any authorized change in the printed recommendations concerning the use of our products must bear the signature of the BASF Technical Manager.

This information and all further technical advice are based on BASF's present knowledge and experience. However, BASF assumes no liability for providing such information and advice including the extent to which such information and advice may relate to existing third party intellectual property rights, especially patent rights. In particular, BASF disclaims all CONDITIONS AND WARRANTIES, WHETHER EXPRESS OR IMPLIED, INCLUDING THE IMPLIED WARRANTIES OF FITNESS FOR A PARTICULAR PURPOSE OR MERCHANTABILITY, RESPECTING ITS PRODUCTS, and BASF shall have no other liability with respect thereto. Any claim regarding product defect must be received in writing within one (1) year from the date of shipment. No claim will be considered without such written notice or after the specified time interval. User shall determine the suitability of the products for the intended use and assume all risks and liability in connection therewith. Any authorized change in the printed recommendations concerning the use of our products must bear the signature of the BASF Technical Manager.

For professional use only. Not for sale to or use by the general public.

Panel Coring at Joint



Core 1

Comparison of Strain Gages Used in Tongue and Groove Joint Testing

On the first day of testing the panels were instrumented with 5 strain gages and 5 BDI gages, but no displacement gages. This was done as a separate exercise to determine the correlation between the BDI gages and standard foil gages. The second day of testing, the displacement gages were added as well as 4 additional strain gages.

The BDI gages and the traditional foil gages show different changes in relation to strain after cracking. Higher strain levels were recorded from the BDI gages while lower strains were recorded from the foil gages. This behavior was attributed to the nature of each instrumentation type and does not change the fact that the foil gages agree with each other after cracks are present. It should be noted, however, that the BDI gages can be considered more accurate due to their greater length on either side of the cracks. Traditional foil gages are much smaller and if located near cracks can feel a relief of strain that may not be accurate.

Results from the two different gage types can be seen in the charts below. See Gage Layout for location of strain gages S1 and S3.

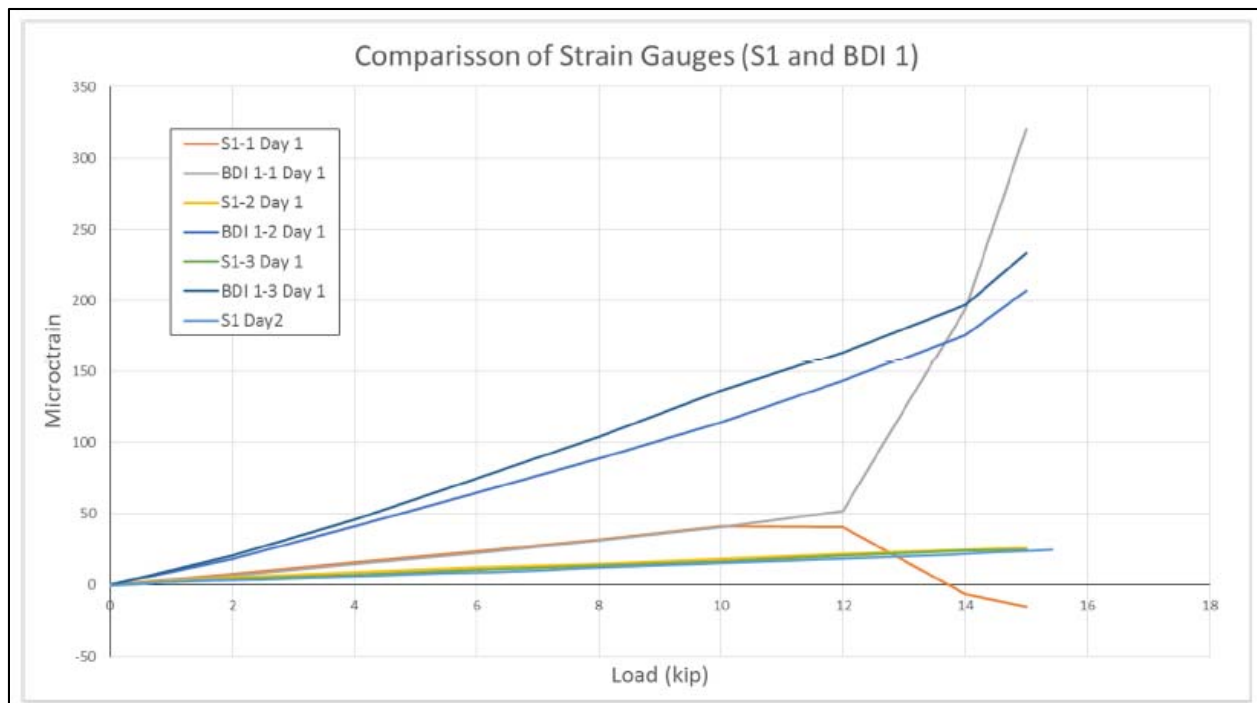

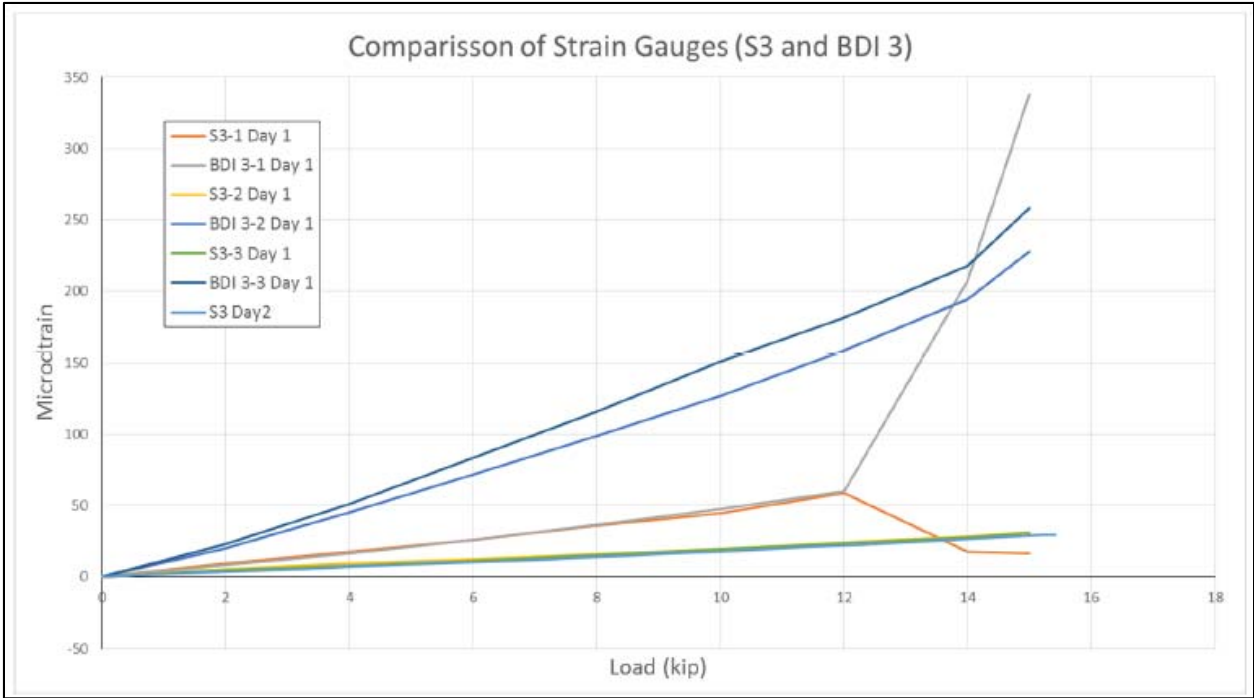

Calculations for Panel Testing

Concrete Unit Weight	$\gamma_c := .145 \frac{\text{kip}}{\text{ft}^3}$
Reinforcement Yield Strength	$f_y := 60\text{ksi}$
Panel Width	$b := 8.177\text{ft}$
Panel Thickness	$t := 8\text{in}$
Total Panel Length	$L := 12\text{ft}$
Unsupported Length	$L_{\text{clear}} := 8\text{ft}$
Distance from edge of support to point load	$a := 4\text{ft}$
Area of steel (longitudinal, bottom)	$A_s := 8 \cdot 0.2\text{in}^2 = 1.6 \cdot \text{in}^2$
Distance from extreme compressive fiber to centroid of reinforcing steel	$d_s := 6.25\text{in}$
Panel self weight	$w_{\text{sw}} := \gamma_c \cdot b \cdot t = 0.79 \cdot \text{klf}$
Average Concrete compressive strength the day of testing	$f'_c := 9.049\text{ksi}$

Applicable equations

Moment before loading	$M_{\text{before_loading}} := \frac{w_{\text{sw}} \cdot L_{\text{clear}}^2}{8} = 6.32 \cdot \text{kip} \cdot \text{ft}$
Equation for moment after load (P) is applied	$M_{\text{total}} = M_{\text{before_loading}} + \frac{P}{2} \cdot a$
where	$\frac{a}{2} = 24 \cdot \text{in}$
Maximum load applied during testing	$P := 15\text{kip}$
	$M_{\text{total}} := M_{\text{before_loading}} + \frac{P}{2} \cdot a = 36.32 \cdot \text{kip} \cdot \text{ft}$
Theoretical Value	$M_T := A_s \cdot f_y \cdot \left[d_s - \frac{1}{2} \cdot \left(\frac{A_s \cdot f_y}{0.85 \cdot f'_c \cdot b} \right) \right] = 49.49 \cdot \text{kip} \cdot \text{ft}$
Demand Capacity Ratio	$\frac{M_{\text{total}}}{M_T} = 73. \%$