

| <b>JANUARY 1, 2008 UPDATES</b>             |                      |
|--|----------------------|
| <b>SUMMARY OF REVISED PAGES - VOLUME 2</b> |                      |
| <b>CHAPTER</b>                             | <b>2-SIDED PAGES</b> |
| Color Cover                                | Complete             |
| Inside Cover                               | Complete             |
| Chapter 2                                  | 7-12                 |
| Chapter 3                                  | Entire Chapter       |
| Chapter 5                                  | Entire Chapter       |
| Chapter 7                                  | Entire Chapter       |
| Chapter 8                                  | Entire Chapter       |
| Chapter 9                                  | 3-4                  |
| Chapter 10                                 | 7-8, 11-14           |
| Chapter 14                                 | 1-2                  |
| Chapter 20                                 | 1-2                  |
| Chapter 22                                 | 1-4                  |
| Chapter 23                                 | 1-2                  |
| Chapter 24                                 | 1-2, 11-14           |
| Chapter 25                                 | 1-2                  |

| <b>SUMMARY OF REVISED PAGES - EXHIBITS</b> |                    |
|--|--------------------|
| <b>CHAPTER</b>                             | <b>EXHIBITS</b>    |
| Chapter 3                                  | KS-1               |
| Chapter 5                                  | BHD-1              |
| Chapter 6                                  | TYP-1 thru TYP-16  |
| Chapter 7                                  | SQ-1 thru SQ-4     |
| Chapter 8                                  | SDS-1a thru SDS-3a |
| Chapter 9                                  | PL-1, GN-1         |
| Chapter 10                                 | PP-2               |
| Chapter 14                                 | DS-1 thru DS-2     |
| Chapter 17                                 | SS-1               |
| Chapter 21                                 | SCG-1 thru SCG-2   |
| Chapter 24                                 | T-MA               |
| Chapter 26                                 | LD-1               |
| Chapter 28                                 | SWP-1 thru SWP-3   |



# PLANS PREPARATION AND ASSEMBLY



**STATE OF FLORIDA  
DEPARTMENT OF TRANSPORTATION**

**CONTRACT PLANS**

FINANCIAL PROJECT ID 196058-1-52-01  
(FEDERAL FUNDS)  
MANATEE COUNTY (13160)  
STATE ROAD NO. 70

**COMPONENTS OF CONTRACT PLANS SET**  
ROADWAY PLANS  
DRAINAGE AND PREVENTION DIVISION PLANS  
COLLECTION PLANS  
LANDSCAPE PLANS  
LANDSCAPE PLANS  
ARCHITECTURAL PLANS  
STRUCTURE PLANS

**INDEX OF ROADWAY PLANS**

| SHEET NO. | SHEET DESCRIPTION                  |
|-----------|------------------------------------|
| 1         | SEE SHEET                          |
| 2 - 2A    | BRIEFING OF THE ITEMS              |
| 3         | DRAINAGE MAP                       |
| 4 - 5     | TYPICAL SECTIONS                   |
| 6         | TYPICAL SECTION DETAILS            |
| 7         | BOUNDARY OF RIGHTS                 |
| 8 - 10    | SOIL COUNTY DATA SHEETS            |
| 11 - 12   | BACK-OF-ROADSIDE PROFILES          |
| 13 - 14   | BRIEFING OF DRAINAGE STRUCTURES    |
| 15 - 16   | ROADWAY PLAN-PROFILES              |
| 17 - 18   | SPECIAL PROFILES                   |
| 19 - 20   | INTERSECTION LAYOUT/DETAIL         |
| 21 - 22   | DRAINAGE STRUCTURES                |
| 23 - 24   | LATERAL DETAIL PLAN-PROFILES       |
| 25 - 26   | LATERAL DETAIL CROSS SECTIONS      |
| 27 - 28   | SPECIAL DETAILS                    |
| 29 - 30   | TRAFFIC CONTROL PLANS              |
| 31 - 32   | UTILITY ADJUSTMENTS                |
| 33 - 34   | SELECTIVE CLEANING AND MAINTENANCE |

**INDEX OF PROJECT**

**ROADWAY SHOP DRAWINGS TO BE SUBMITTED TO:**  
HARRY P. BLAIR  
HILL & DALE ENGINEERS, INC.  
P.O. BOX 600  
TAMPA, FLORIDA 33610

**PLANS PREPARED BY:**  
HILL & DALE ENGINEERS, INC.  
P.O. BOX 600  
TAMPA, FLORIDA 33610  
CERTIFICATE OF AUTHORIZATION NO. 1000  
CONTRACT NO. 6-4002  
VEHICLE REG. 30

**NOTE:** THIS PROJECT TO BE SET TO MATCH WITH FINANCIAL PROJECT ID 1960-00-01.

**NOTE:** THE SCALE OF THESE PLANS MAY VARY FROM SHEET TO SHEET.

**PROVISIONS**  
FINANCIAL PROJECT ID 1960-00-01  
Drawing Sheet 1 & 1-A of 10  
Utility & Powering Drawing Sheet 1-1  
Right-of-Way Drawing Sheet 1-2 & 1-3  
Right-of-Way Drawing Sheet 1-4 & 1-5  
Right-of-Way Drawing Sheet 1-6 & 1-7  
Right-of-Way Drawing Sheet 1-8 & 1-9  
Right-of-Way Drawing Sheet 1-10 & 1-11

**PROVISIONS**  
FINANCIAL PROJECT ID 1960-00-01  
Drawing Sheet 12, 13 & 14 of 10  
Right-of-Way Drawing Sheet 1-12 & 1-13  
Right-of-Way Drawing Sheet 1-14 & 1-15

**PROJECT LENGTH IS BASED ON E CONSTRUCTION**

| LENGTH OF PROJECT       |             |
|-------------------------|-------------|
|                         | LINEAR FEET |
| ROADWAY                 | 346579      |
| BRIDGES                 | 0           |
| NET LENGTH OF PROJECT   | 346579      |
| EXCEPTING               | 0           |
| GROSS LENGTH OF PROJECT | 346579      |

**NET SHEET REVISIONS**

| NO. | DATE   | DESCRIPTION                         |
|-----|--------|-------------------------------------|
| 1   | 1/1/06 | Initial Contract & Adjustment Sheet |

**PROJECT DIVISION** TRUCKS/OLP

**FDOT**



**DESIGN**

Volume  
II

Plans Preparation Manual

January 2006

**Revised – January 1, 2008**

# PLANS PREPARATION AND ASSEMBLY



Florida Department Of Transportation

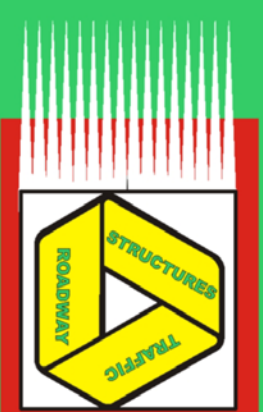

# PLANS PREPARATION MANUAL

## VOLUME II

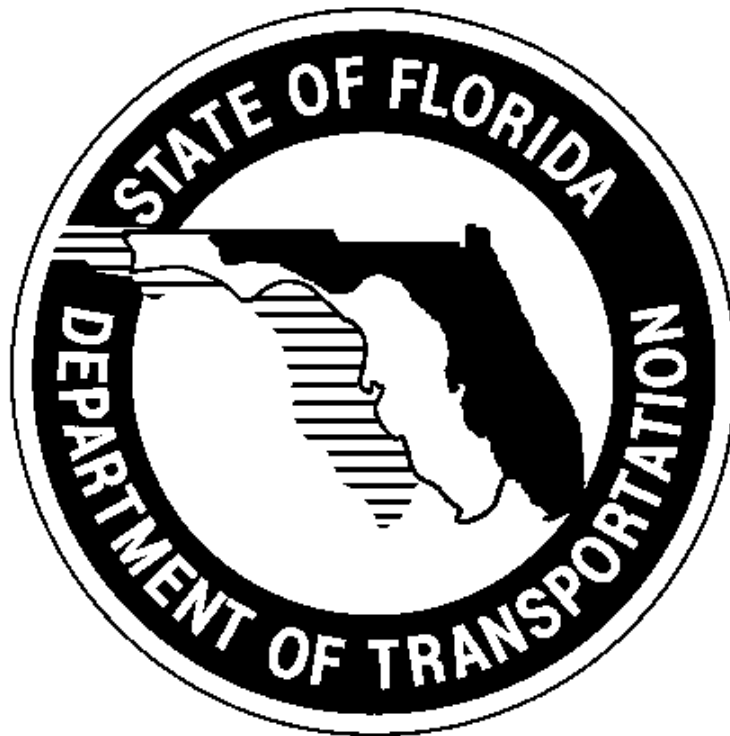

### ROADWAY DESIGN OFFICE

TALLAHASSEE, FLORIDA

JANUARY 1, 2006

THIRD EDITION

REVISED – JANUARY 1, 2008

<http://www.dot.state.fl.us/rddesign/PPMManual/PPM.htm>

**THIS PAGE LEFT BLANK INTENTIONALLY**

**Figure 2.1 Summary of Phase Submittals**

| ITEM  | PHASE | PHASE* | PHASE | PHASE |
|---|-------|--------|-------|-------|
|   | I     | II     | III   | IV    |
| Key Sheet                                     | P     | P      | C     | F     |
| Summary of Pay Items                          |       | P      | C     | F     |
| Drainage Map                                  | P     | P      | C     | F     |
| Interchange Drainage Map                      | P     | P      | C     | F     |
| Typical Section                               | P     | C      | C     | F     |
| Summary of Quantities                         |       |        | C     | F     |
| Summary of Drainage Structures                |       |        | C     | F     |
| Optional Materials Tabulation                 |       | P      | C     | F     |
| Project Layout                                | P     | C      | C     | F     |
| Roadway Plan-Profile                          | P     | P      | C     | F     |
| Special Profile                               | P     | P      | C     | F     |
| Back-of-Sidewalk Profile                      | P     | C      | C     | F     |
| Interchange Layout                            | P     | P      | C     | F     |
| Ramp Terminal Details                         |       | P      | C     | F     |
| Intersection Layout/Detail                    | P     | P      | C     | F     |
| Drainage Structures                           |       | P      | C     | F     |
| Three-Sided/Box Culvert Details               |       |        | C     | F     |
| Lateral Ditch Plan-Profile                    |       | P      | C     | F     |
| Lateral Ditch Cross Section                   |       | P      | C     | F     |
| Retention/Detention Ponds                     |       | P      | C     | F     |
| Cross Section Pattern                         |       | P      | C     | F     |
| Roadway Soil Survey                           |       | P      | C     | F     |
| Cross Sections                                | P     | P      | C     | F     |
| Stormwater Pollution Prevention Plan          |       | P      | C     | F     |
| Traffic Control Plans                         | P     | P      | C     | F     |
| Utility Adjustment                            |       | P      | C     | F     |
| Selective Clearing and Grubbing               |       | P      | C     | F     |
| Mitigation Plans                              |       | P      | C     | F     |
| Miscellaneous Structures Plans                |       | P      | C     | F     |
| Signing and Pavement Marking Plans            |       | P      | C     | F     |
| Signalization Plans                           |       | P      | C     | F     |
| Intelligent Transportation System (ITS) Plans |       | P      | C     | F     |
| Lighting Plans                                |       | P      | C     | F     |
| Landscape Plans                               | P     | P      | C     | F     |
| Utility Joint Participation Agreement Plans   |       |        | C     | F     |
| Computation Book                              |       |        | C     | F     |
| Contract Time                                 |       |        | P     | F     |

**Status Key:**

- P** - Preliminary
- C** - Complete but subject to change
- F** - Final

\* Projects which have a structures plans component are required to submit the latest set of structures plans with the Phase II roadway submittal.

## 2.3.2.1 Requirements for Phase I Submittal

Unless otherwise directed by the district, the following elements are required for a Phase I set of plans.

### **KEY SHEET**

Location Map w/ location of project on map  
All applicable Financial Project ID's  
(Federal Funds) notation, if applicable  
Exceptions & Equations  
County Name  
State Road Number  
Length of project box  
North arrow and scale  
Approval signature lines  
Railroad crossing (if applicable)  
Revision box  
Governing Standards & Specifications dates  
Project Manager's Name  
Begin & end project station and begin mile post  
Begin & end bridge stations  
Consultant's name, address, contract number,  
Certificate of Authorization number and vendor  
number (if applicable)

### **DRAINAGE MAP - PLAN VIEW**

North arrow and scale  
Drainage divides and ground elevations  
Drainage areas and flow direction arrows  
Equations  
High water information as required  
Preliminary horizontal alignment  
Section, township, range lines  
Street names  
Begin & end stations of project, bridge, bridge  
culverts & exceptions  
Existing structures & pipes with relevant  
information

State, Federal, county highway numbers (as  
appropriate)

### **DRAINAGE MAP - PROFILE VIEW**

Preliminary profile grade & existing ground line  
Horizontal & vertical scale  
Begin & end stations of project, bridges, bridge  
culverts & exceptions  
Equations

### **INTERCHANGE DRAINAGE MAP**

North arrow and scale  
Stationing along baselines  
Ramp baselines with nomenclature  
Begin and end bridge stationing  
Preliminary interchange configuration  
R/W lines  
Preliminary interchange drainage with drainage  
areas and flow direction arrows

### **TYPICAL SECTIONS**

Mainline and crossroad typicals  
R/W lines  
Special details (bifurcated sections, high fills,  
etc.)  
Traffic data

### **PROJECT LAYOUT / Reference Points**

Plan-profile sheet sequence (mainline and  
crossroads)  
Reference points (if layout sheet is required)

### **PLAN AND PROFILE - PLAN VIEW**

North arrow and scale  
Baseline of survey, equations  
Curve data (including superelevation)  
Existing topography including utilities  
Preliminary horizontal geometrics/dimensions  
Existing & proposed R/W lines (if available)  
Centerline of construction (if different from the baseline of survey)  
Begin and end stations for the project, bridges, bridge culverts and exceptions  
Reference points (if project layout sheet not included in plans set)

### **PLAN AND PROFILE - PROFILE VIEW**

Scale  
Appropriate existing utilities  
Bench mark information  
Preliminary profile grade line  
Equations  
Existing ground line with elevations at each end of sheet  
Begin and End Stations for the Project, bridges, bridge culverts and exceptions.

### **SPECIAL PROFILE**

Scale  
Ramp profile worksheet including nose sections  
Existing ground line of intersections  
Preliminary grade line of intersections  
Preliminary curb return profiles, if applicable

### **BACK-OF-SIDEWALK PROFILE (Worksheet)**

Scale  
Begin and end project stations  
Begin and end sidewalk stations  
Cross-street locations and elevations  
Drainage flow direction arrows  
Mainline equations  
Existing driveway locations and details

Superelevation details  
Back-of-sidewalk profile grades and vertical curve information  
Building floor elevations with offset distance left and right  
Gradeline notation: Specifically the numeric difference relative to roadway profile gradeline

### **INTERCHANGE DETAIL**

North arrow and scale  
Schematic of traffic flow and volumes  
Proposed bridge limits  
R/W lines  
Preliminary configuration and geometrics  
Quadrant Identification  
Ramp Labels

### **INTERSECTION LAYOUT**

North arrow and scale  
Existing topography (if applicable)  
Proposed R/W limits  
Length of turn lanes  
Taper lengths  
Existing Utilities  
Geometric dimensions (radii, offsets, widths)

### **CROSS SECTIONS\***

Scale  
Existing ground line  
Existing survey baseline elevations  
Station numbers  
Baseline of survey labeled  
Existing utilities  
Proposed template with profile grade elevations along mainline and cross-streets as necessary

### **TRAFFIC CONTROL PLANS**

Project specific  
Other worksheets as necessary to convey concept and scope.

### **LANDSCAPE PLANS**

Conceptual landscape plan

\*May require accompanying cross section pattern sheet

## 2.3.2.2 Requirements for Phase II Submittal

Unless otherwise directed by the district, the following elements are required for a Phase II set of plans.

### KEY SHEET

Index of sheets  
Contract plans and component plans list

### SUMMARY OF PAY ITEMS

Item numbers with descriptions (on 8 ½" x 11" paper until the project proposal has been created)

### DRAINAGE MAP - PLAN VIEW

Proposed structures with structure numbers  
Proposed storm drain pipes  
Flow arrows along proposed ditches  
Retention/Detention ponds, pond number and area size  
Cross drains with pipe sizes and structure numbers  
Bridges/bridge culverts with begin and end stations  
Flood data (if applicable)

### DRAINAGE MAP - PROFILE VIEW

Ditch gradients including DPIs  
Final roadway profile grade line  
Mainline storm drain pipes  
Mainline flow line elevations  
Mainline structures with structure numbers and pipes  
Bridge, Bridge Culvert  
Cross drains with pipe sizes, structure numbers and flow line elevation

### INTERCHANGE DRAINAGE MAP

Final geometrics including PC and PT  
Proposed structures with structure numbers  
Proposed storm drain pipes  
Special ditches with DPI and elevation

### TYPICAL SECTIONS

Pavement Design

### OPTIONAL MATERIALS TABULATION

Material type  
Structure number station and description  
Durability, cover requirements  
Optional culvert material application  
Culvert service life estimator  
Design service life

### PROJECT LAYOUT

Complete

### PLAN AND PROFILE - PLAN VIEW

Curb return numbers, station ties and elevations  
Proposed drainage structures with structure no.  
Proposed R/W lines  
Existing utilities  
Proposed side drain pipe requirements (including size) for access and intersections  
Final geometrics and dimensions including radii, station pluses, offsets, widths, taper/transition lengths, curve data  
General notes (if project layout sheet not included)  
Flood data if not shown elsewhere  
Limits of wetlands

### PLAN AND PROFILE - PROFILE VIEW

Final profile grades and vertical curve data  
Mainline storm drain pipes  
Proposed special ditches  
Ditch gradients with DPI station and elevation  
Non-standard superelevation transition details  
High water elevations  
Existing utilities  
Mainline drainage structures with structure numbers  
Cross drains with structure number, size and flow line elevations

**SPECIAL PROFILE**

Final intersection profile grades  
Final curb return profiles (if applicable)  
Superelevation diagrams as required  
Final ramp profile grades including nose sections  
Preliminary access and frontage road profiles (may contain one or more types of special profiles.)

**BACK-OF-SIDEWALK PROFILE**

Complete

**INTERCHANGE LAYOUT**

Curve data including superelevation and design speed  
Coordinate data, stationing and ties  
Access and/or frontage roads with dimensions and R/W  
Fence location  
Ramp identification

**RAMP TERMINAL DETAILS**

Preliminary geometrics  
Radii, transition/taper lengths  
Ramp identification

**INTERSECTION LAYOUT**

Limits of proposed construction along side roads  
Applicable notes  
Cross drains with structure numbers and pipe sizes  
Storm drain pipes including sizes  
Final geometrics including dimensions, radii, offsets, station pluses and taper/transition lengths

**DRAINAGE STRUCTURES**

Vertical and horizontal scale  
Roadway template with profile grade elevation  
Underground utilities  
Special sections at conflict points  
R/W lines (at critical locations)  
Storm drain construction notes  
Flow arrows  
Applicable notes  
Structure numbers and location station along right side of sheet  
Drainage structures with numbers in numerical order, type, size, location and flowline elevations

**OUTFALL / LATERAL DITCH SYSTEM - PLAN VIEW**

North arrow and scale  
Roadway centerline  
Existing and/or survey ditch centerline  
Proposed ditch centerline with stationing  
Begin and end ditch stations  
Equations  
Ditch centerline intersection stations  
R/W lines  
Bearings of ditch and mainline centerlines  
Proposed storm drain pipes  
Ditch PI stations with deflection angle left or right  
Proposed drainage structures with structure numbers  
Existing topography, drainage structures, utilities  
Limits of wetlands

**OUTFALL / LATERAL DITCH SYSTEM -  
PROFILE VIEW**

Bench mark information  
Scale  
Existing ground line  
Proposed ditch profile with grades  
Begin and end ditch stations  
High water elevations  
Proposed storm drain pipes with size  
Existing Utilities  
Overland flow or overtopping elevations  
Proposed drainage structures with structure numbers  
Typical section can be placed in either plan or profile

**LATERAL DITCH CROSS SECTIONS**

Horizontal and vertical scale  
Existing ground line  
Station numbers  
Survey centerline and elevation  
R/W  
Begin and end ditch stations  
Begin and end excavation stations  
Earthwork quantities  
Existing utilities  
Total earthwork quantity in cubic yards (CY)  
Proposed template with ditch bottom elevation

**RETENTION/DETENTION POND DETAILS**

North arrow and scale  
Roadway centerline ties  
Proposed pond centerline with stationing  
Begin and end pond stations  
Side slopes, dimensions, and elevations  
R/W lines  
Berm, fence and gate locations  
Soil boring information  
Proposed pond drainage structures with structure numbers  
Existing topography, drainage structures, utilities  
Pond sections (2 perpendicular to each other)  
Pond Typical Section  
Limits of wetlands

**RETENTION/DETENTION POND CROSS  
SECTIONS**

Horizontal and vertical scale  
Existing ground line  
Station numbers  
Begin and end pond stationing  
Pond centerline and elevations  
R/W  
Soil borings  
Water table  
Extent of unsuitable material  
Earthwork quantities  
Existing utilities  
Proposed template with bottom elevation

**CROSS SECTION PATTERN**

North arrow and scale  
Interchange layout  
Access and frontage roads  
Mainline and ramp stationing  
Begin and end bridge stations  
Cross section location lines  
Ramp baselines with nomenclature and stationing

**ROADWAY SOIL SURVEY**

Soil data  
Project specific

**CROSS SECTIONS**

R/W  
Special ditch bottom elevations  
Equivalent stations for ramps and mainline  
Mainline equation stations  
Soil borings  
Water table  
Extent of unsuitable material  
Proposed template with profile grade elevation  
Earthwork Columns  
Begin and end stationing for project, construction and earthwork, bridge and bridge culvert  
Existing utilities affected by the template and where unsuitable materials are present

## Chapter 3

### Key Sheet

|             |   |      |
|-------------|---|------|
| 3.1         | General .....   | 3-1  |
| 3.2         | Project Identification .....  | 3-2  |
| 3.2.1       | Financial Project ID, Federal Funds, County Name<br>and State Road Number ..... | 3-2  |
| 3.2.2       | Fiscal Year and Sheet Number .....  | 3-3  |
| 3.2.3       | Length of Project Box.....  | 3-3  |
| 3.3         | Project Location Map .....  | 3-5  |
| 3.4         | North Arrow and Scale .....   | 3-7  |
| 3.5         | Component Plans in Contract Plans Set.....                                      | 3-8  |
| 3.6         | Index of Sheets .....   | 3-9  |
| 3.7         | Professional Responsibility .....   | 3-11 |
| 3.8         | Governing Standards and Specifications .....                                    | 3-12 |
| 3.9         | State Map.....  | 3-12 |
| 3.10        | Railroad Crossing.....  | 3-13 |
| 3.11        | Revisions.....  | 3-13 |
| Exhibits    |   |      |
| Exhibit 3-1 | Standard Key Sheet Notes.....   | 3-14 |

**THIS PAGE LEFT BLANK INTENTIONALLY**

## Chapter 3

### Key Sheet

#### 3.1 General

This is the first sheet in the contract plans. It describes the project, the contents of the plans, and identifies those responsible for preparing the plans. The key sheet cell can be found in the FDOT Engineering/CADD Systems Software. Levels and fonts for additional data can be found in the FDOT ***CADD Production Criteria Handbook***.

For key sheet example, see ***Exhibit KS-1***.

## 3.2 Project Identification

Background: On May 21, 1997, the State Highway Engineer instructed District Secretaries on the implementation of the Financial Management System. This system replaces the Work Program Administration, the Job Cost Reporting and the Federal Project Accounting systems. Once implemented, all contract documents/sheets that historically had shown project or WPI numbers were to have the new project number on every sheet. Beginning March 16, 1998, a Financial Project ID was assigned to each old project, and from then on new projects have been assigned the Financial Project ID only. In his memorandum to the District Design Engineers dated April 22, 1998, the State Roadway Design Engineer requested that, starting with the plans packages mailed to Tallahassee for the January 1999 letting, the new number be printed on all sheets. On June 30, 1998, the Secretary instructed the Department to use the Financial Project ID in all project documents.

### 3.2.1 Financial Project ID, Federal Funds, County Name and State Road Number

The Financial Project ID is the main number identifying each individual project within the Department. On the key sheet, this number is located immediately under the heading "CONTRACT PLANS", as shown in the exhibits. Where Federal funds are involved, the words "(Federal Funds)" are to be placed under the Financial Project ID. The county name and the state road number will be included under the Financial Project ID. Also, the "county and roadway section number" associated with Straight Line Diagrams will be placed within parentheses to the right of the county name, as shown on **Exhibit KS-1**.

Strung projects, those that are independently prepared but are to be let in the same construction contract, shall have the additional Financial Project IDs noted on the right side of the key sheet.

On projects which have one Contract plans set, but multiple Financial Project ID's, all of the Financial Project ID's are located immediately under the heading "CONTRACT PLANS" on the key sheet. On all other plan sheets, the lead Financial Project ID is to be shown. See **Exhibits 3-1** and **KS-1** for an example of this note.

## 3.2.2 Fiscal Year and Sheet Number

The construction fiscal year to be entered in the fiscal year box on the bottom right corner is the second year in the fiscal year, i.e., enter 01 for fiscal year beginning July 2000 and ending June 2001. The key sheet of each component of the plans set will be numbered as the first sheet of that component.

## 3.2.3 Length of Project Box

Lengths of roadway, bridges, bridge culverts, exceptions, and net and gross lengths of the project shall be shown in a box in the center of the sheet below the location map. The length of the project is computed as follows:

1. Roadway = End Project - Begin Project - Exceptions - Bridges (not including bridge culverts) adjusted for Equations
2. Net = Roadway + Bridges
3. Gross = End Project - Begin Project (adjusted for Equations)

The roadway and bridge length shall be computed in feet and converted to miles, to three decimal places, without rounding off. The roadway and/or bridge mileage shall then be rounded so that their total equals the net length. The survey line should be used to compute the length of the project unless: the construction line is substantially different in length (100 feet or more), or the survey line is outside the right of way, or the survey line bridge length is different from the construction line bridge length. The use of the survey line will generally result in fewer equations on the key map. If a line other than the baseline of survey is used to compute the length of a project, a note stating which line was used is to be placed adjacent to the length of the project box.

If divided highways have significantly different lengths for the left and right roadways, the project length shall be based on the longer roadway. A note stating which roadway was used shall be placed adjacent to the project length box.

The "Begin Project" and "End Project" stations are the basis for computing the length. Begin and end construction stations are not to be used in computing the length of the project.

A length of project box is not required on component key sheets.

**THIS PAGE INTENTIONALLY LEFT BLANK**

### 3.3 Project Location Map

This map is placed in the center of the sheet and consists of a reproduced portion of one or more maps showing the project location. The map may be a county map or other appropriate map. County maps in microstation(\*.dgn)format are available from the Survey and Mapping Office on CD or can be individually downloaded by county and included as a reference attachment. Information on the county maps is available at:

<http://www.dot.state.fl.us/surveyingandmapping/geographic.htm>

A utility to download the county map and clip out the project location area is provided in the **FDOT CADD Software**. Requests for county maps on CD should be in writing and include the county requested, the purpose for the use, the anticipated duration of the use, the Department of Transportation project manager's name and a CD upon which to copy the data. Requests should be directed to:

Florida Department of Transportation  
Survey & Mapping Office  
605 Suwannee Street, MS 5L  
Tallahassee, Florida 32399-0450  
(850) 414-1555

The intent of the location map is to provide enough information so that the project location is easily understood. This may make it necessary to show the Section, Township, Range and County lines together with Section, Township and Range numbers to make the location clear. City and urban limits should be shown where applicable.

Streets shall be designated by name and State Road number or U.S. Highway number, if appropriate. The name of the next incorporated city to which these roads lead shall be placed at the edge of the map. Roads and topography shall be indicated by standard symbols as shown in the **Design Standards, Index 002** and FDOT Engineering/CADD Systems Software.

Project location shall be shown by a heavy solid line of substantial width. It is sometimes advantageous to show station numbers at regular intervals, particularly with city street projects. The begin and end of projects, any station equations, begin and end of proposed bridges along the state project, bridge culverts and exceptions shall be stationed and flagged. Begin stations shall be shown for each project. The begin milepost, correct to three decimal places shall be shown under the begin project station. Except for begin stations at the beginning of each project, description by milepost may be permitted if station information is not available. All station information is to be consistent with the station

information entered into the Work Program Administration system during final design. See **Volume I, Section 14.2.**

When several projects are covered by the same set of plans, the beginning and end of each project shall be indicated clearly by the Financial Project ID and stationing. The beginning of each project shall also be indicated by a milepost correct to three decimal places.

The scale of the location map should be chosen so that it will not interfere with other features on the key sheet. A common error is to position the location map on the sheet and then discover that insufficient space remains for the index of sheets, project title or the length of project box.

A location map is not required on component key sheets.

### **3.4 North Arrow and Scale**

The north arrow shall be placed on either side of the location map, preferably to the right. The map scale shall be shown directly below the north arrow. The scale shall be indicated by using a bar scale. The scale distance shall be shown between the ticks. The map shall be oriented so that the arrow will point toward the top of the sheet. If the arrow cannot be oriented to the top, then it must be oriented to point to the right.

### 3.5 Component Plans in Contract Plans Set

A list of component plans included in the contract plans set shall be shown in the upper left corner. The order of listing shall be:

1. Roadway
2. Signing and Pavement Marking
3. Signalization
4. Intelligent Transportation Systems (ITS)
5. Lighting
6. Landscape
7. Architectural
8. Structures

If sheets covering items such as signing and pavement markings, signalization, ITS, lighting and landscape are included and numbered consecutively within the roadway plans (or structures plans if lead project), these are not to be shown as components of the contract plans set.

If the plans are structures plans and there is no work on the approach roadway, the structures plans become the lead project. Any other sheets incidental to the project typically found within the roadway plans or other component plans (i.e., traffic control plans, signing and marking, etc.), may be included in the structures plans and numbered consecutively in accordance with the ***Structures Manual, Volume 2 – Structures Detailing Manual***.

## 3.6 Index of Sheets

A complete index of roadway plan sheets shall be placed on the left side of the key sheet under the heading. When projects contain component plans, each component plans set shall have an index of sheets on its respective key sheet.

Roadway plans sheets shall be assembled as follows:

1. Key Sheet
2. Summary of Pay Items
3. Drainage Map (optional)
4. Interchange Drainage Map
5. Typical Section
6. Summary of Quantities
7. Summary of Drainage Structures
8. Optional Materials Tabulation
9. Project Layout (optional)
10. General Notes (optional)
11. Roadway Plan-Profiles
12. Special Profiles
13. Back-of-Sidewalk Profiles (optional)
14. Interchange Layout
15. Ramp Terminal Details
16. Intersection Layout/Detail
17. Drainage Structures
18. Three-Sided/Box Culvert Details
19. Outfall/Lateral Ditch Plan-Profiles
20. Outfall/Lateral Ditch Cross Sections
21. Special Details
22. Cross Section Pattern
23. Roadway Soil Survey

24. Cross Sections
25. Stormwater Pollution Prevention Plans (SWPPP)
26. Traffic Control Plans
27. Utility Adjustments
28. Selective Clearing and Grubbing
29. Signing and Pavement Marking Plans\*
30. Signalization Plans\*
31. ITS Plans\*
32. Lighting Plans\*
33. Landscape Plans\*
34. Mitigation Plans
35. Miscellaneous Structures Plans

\* When not separate component plans.

In addition, the roadway plans may contain sheets which were prepared separately (perhaps by a sub-consultant) and incorporated into the roadway plans early in the design process (prior to the establishment of sheet numbering). As an option, these may be identified with the following prefixes and placed at the end of the numbered sequence of the roadway plans:

CTL-# Project Survey Control Sheets

GR-# Soil Survey and Report of Core Borings normally associated with the roadway plans set (including miscellaneous structures but excluding bridges and walls)

TR-# Tree Survey Sheets

UTV-# Verified Utility Locate Sheets

Note: Other component plans may also utilize the sheet prefixes defined in their respective chapters.

### 3.7 Professional Responsibility

The name of the Engineer of Record, Architect or Landscape Architect of Record and registration number shall be included on the right side of the sheet. For specific instructions on sealing plans see ***Volume I, Chapter 19***.

For plans prepared by a consulting firm, the name, address, consultant contract number, certificate of authorization number and vendor number of the firm shall be shown on the right side of the sheet.

The Department Project Manager's name shall be shown below the length of project box for consultant and Department prepared plans. For key sheets where length of project is not required, the Department Project Manager's name shall be shown in the same relative location on the sheet.

If shop drawings are anticipated for a project, the name(s) and address(es) of the Delegated Engineer(s) for shop drawing review(s) shall be shown on the right side of the sheet.

### 3.8 Governing Standards and Specifications

The dates of the governing ***Design Standards*** and the ***Standard Specifications for Road and Bridge Construction*** shall be inserted in a note at the lower left corner of the lead key sheet of each plan set.

A document entitled ***Design Standards Modifications*** includes a listing of all Interim Design Standards issued since publication of the applicable booklet, plus all changes and corrections to notes and text within the booklet that do not warrant the issuance of Interim Indexes (previously handled by Special Provision). The Design Standards Modifications documents will be dated, and posted on the same web site as the Design Standards. The Design Standards Modifications will typically be updated and posted in January and July, 6 months prior to the effective letting date. For example, ***Design Standards Modifications*** dated July 1, 2005 will be posted on the web site in January 2005, but will be effective beginning with the July 2005 letting. Special updates to the Design Standards Modifications posted in between January and July will only be issued when necessary to address changes of immediate concern. When this occurs, email notification will be sent to the Districts and registered Plans Preparation Manual holders.

The applicable Design Standards Modifications and date, and Internet address shall be shown on the lower left corner of the lead key sheet of each plan set, below the Governing Specifications and Standards note, and above the Revisions area. Note that all Interim Indexes listed in the Design Standards Modifications document will be applicable. ***Interim Standards*** shall not be attached to the Contract Plans Set.

The Governing Specifications and Standards note and the Design Standards Modifications note shall not be shown on the key sheets of component plans that are listed on the lead key sheet of each plan set. ***Exhibits 3-1*** and ***KS-1*** give examples on how these notes are shown.

### 3.9 State Map

A small-scale state map shall be shown at the upper right portion of the key sheet. The location of the project shall be indicated thereon.

### **3.10 Railroad Crossing**

The location of any railroad crossing within the limits of construction will be identified on the key sheet as follows: DOT/AAR crossing number, railroad milepost, name of railroad, and the highway project station number.

### **3.11 Revisions**

The lead key sheet (usually roadway) shall show a complete record of all plans revisions. The component (such as roadway, structures, signing and pavement marking), the sheet numbers involved, and the date when the sheet was revised shall be listed. The unique numbered symbol that corresponds to the Revision Number on the Revision Memo and modified sheets shall be listed here as well.

A newly sealed lead key sheet is required when any sheet is revised.

Revisions shall be shown on the lower left corner of the key sheet in the “Revisions” area. Revisions to strung project sheets shall be listed here, under the respective Financial Project ID.

A Key Sheet Revisions Block shall be shown on the right side of each component key sheet that shall contain a record of all revisions particular to that sheet. It shall list the revision date and a brief description of the revision.

If the changes to a key sheet only involve notes in the Revisions area, no entry is made in the Key Sheet Revisions Block at the lower right corner. The Key Sheet Revisions Block is only used to record changes other than revisions notes.

### **Exhibit 3-1 Standard Key Sheet Notes**

The following are standard Key Sheet notes that shall be shown as applicable:

1. The following note should be used on all strung jobs:  
NOTE: THIS PROJECT TO BE LET TO CONTRACT WITH FINANCIAL PROJECT ID(S)\_\_\_\_\_.
2. The following note to be used on all jobs:  
NOTE: THE SCALE OF THESE PLANS MAY HAVE CHANGED DUE TO REPRODUCTION.
3. The following note should be used on all jobs:  
GOVERNING STANDARDS AND SPECIFICATIONS:  
FLORIDA DEPARTMENT OF TRANSPORTATION, DESIGN STANDARDS DATED 20\_\_, AND STANDARD SPECIFICATIONS FOR ROAD AND BRIDGE CONSTRUCTION DATED 20\_\_, AS AMENDED BY CONTRACT DOCUMENTS.
4. The following notes should be used on all jobs and shown below the Governing Standards and Specifications:  
APPLICABLE DESIGN STANDARDS MODIFICATIONS: MM-DD-YY  
For Design Standards Modifications click on “Design Standards” at the following web site: <http://www.dot.state.fl.us/rddesign/>

**COMPONENTS OF CONTRACT PLANS SET**

- ROADWAY PLANS
- SIGNING AND PAVEMENT MARKING PLANS
- SIGNALIZATION PLANS
- INTELLIGENT TRANSPORTATION SYSTEMS PLANS
- LIGHTING PLANS
- LANDSCAPE PLANS
- ARCHITECTURAL PLANS
- STRUCTURE PLANS

EXAMPLE ONLY: CONTRACT PLANS SET  
MAY NOT CONTAIN ALL OF THE  
LISTED COMPONENTS/SHEETS.

A DETAILED INDEX APPEARS ON THE  
KEY SHEET OF EACH COMPONENT

**INDEX OF ROADWAY PLANS**

| SHEET NO. | SHEET DESCRIPTION                    |
|-----------|--------------------------------------|
| 1         | KEY SHEET                            |
| 2-2A      | SUMMARY OF PAY ITEMS                 |
| 3         | DRAINAGE MAP                         |
| 4-5       | TYPICAL SECTIONS                     |
| 6         | TYPICAL SECTION DETAILS              |
| 7         | SUMMARY OF QUANTITIES                |
| 8-9       | SUMMARY OF DRAINAGE STRUCTURES       |
| 10        | PROJECT LAYOUT                       |
| 11-15     | ROADWAY PLAN-PROFILES                |
| 16-17     | SPECIAL PROFILES                     |
| 18        | INTERSECTION LAYOUT/DETAIL           |
| 19-25     | DRAINAGE STRUCTURES                  |
| 26-32     | BOX CULVERT DETAILS                  |
| 33        | LATERAL DITCH PLAN-PROFILES          |
| 34        | LATERAL DITCH CROSS SECTIONS         |
| 35        | SPECIAL DETAILS                      |
| 36        | ROADWAY SOIL SURVEY                  |
| 37-47     | CROSS SECTIONS                       |
| 48        | STORMWATER POLLUTION PREVENTION PLAN |
| 49-52     | TRAFFIC CONTROL PLANS                |
| 53-57     | UTILITY ADJUSTMENTS                  |
| 58-62     | SELECTIVE CLEARING AND GRUBBING      |

GOVERNING STANDARDS AND SPECIFICATIONS:  
FLORIDA DEPARTMENT OF TRANSPORTATION,  
DESIGN STANDARDS DATED 2008,  
AND STANDARD SPECIFICATIONS FOR ROAD AND  
BRIDGE CONSTRUCTION DATED 2007,  
AS AMENDED BY CONTRACT DOCUMENTS.

APPLICABLE DESIGN STANDARDS MODIFICATIONS: T-1-08

For Design Standards Modifications click on  
"Design Standards" at the following web sites:  
<http://www.dot.state.fl.us/rddesign/>

**REVISIONS**

- FINANCIAL PROJECT ID 000001-1-52-01  
Roadway Sheets 1, 6, 7 & 13 (Revised 01-10-07)
- Signing & Pavement Marking Sheets 5-2 & 5-3 (Revised 3-10-07)
- Signalization Sheets T-1 & T-2 (Revised 3-10-07)
- Roadway Sheets 14 & 33 (Revised 3-31-07)
- Summary of Pay Items (Revised 3-31-07)
- FINANCIAL PROJECT ID 000002-1-52-02  
Roadway Sheets 1, 8 & 10 (Revised 1-30-07)
- Structure Sheets B-1 & C-1 thru C-10 (Revised 1-30-07)

**STATE OF FLORIDA  
DEPARTMENT OF TRANSPORTATION**

**CONTRACT PLANS**

FINANCIAL PROJECT ID 000001-1-52-01  
(FEDERAL FUNDS)  
BAY COUNTY (46001)  
STATE ROAD NO. 220

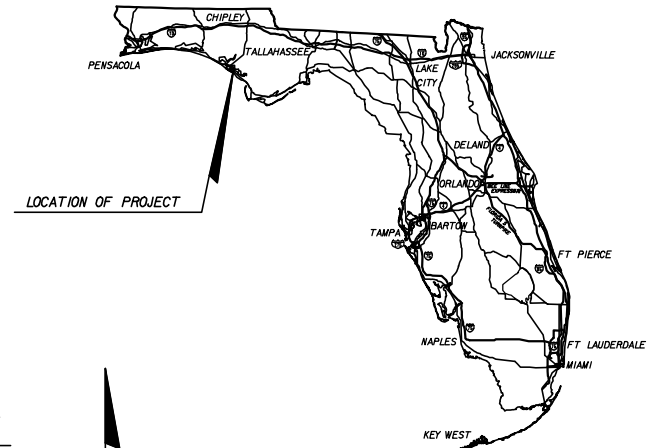

LOCATION OF PROJECT

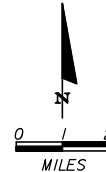
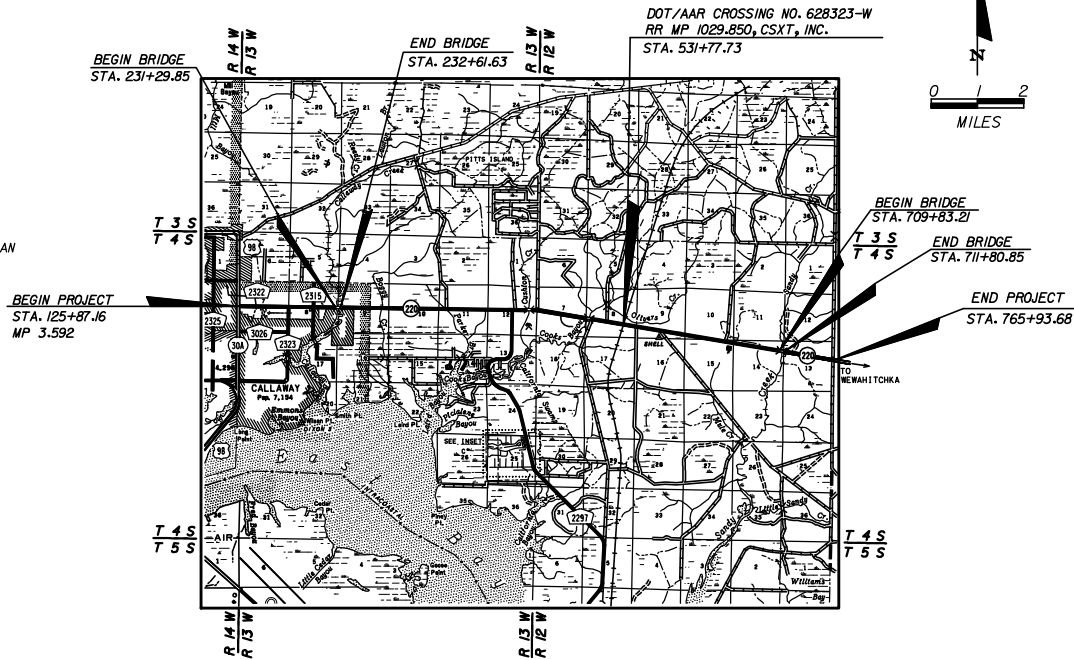

ROADWAY SHOP DRAWINGS  
TO BE SUBMITTED TO:  
  
NAME(S) AND ADDRESS(ES) OF  
ENGINEER(S) RESPONSIBLE FOR REVIEW  
OF SHOP DRAWINGS, WHEN REQUIRED.

PLANS PREPARED BY:  
  
NAME, ADDRESS, CONTRACT NUMBER, VENDOR NUMBER  
AND CERTIFICATE OF AUTHORIZATION NUMBER OF  
THE CONSULTANT FIRM WHEN THE PLANS ARE  
PREPARED BY A CONSULTANT.

NOTE: THIS PROJECT TO BE LET TO CONTRACT  
WITH FINANCIAL PROJECT ID 000002-1-52-02.

NOTE: THE SCALE OF THESE PLANS MAY  
HAVE CHANGED DUE TO REPRODUCTION.

**EXHIBIT KS-1**  
Date: 1/1/08

| LENGTH OF PROJECT     |             |        |
|-----------------------|-------------|--------|
|                       | LINEAR FEET | MILES  |
| ROADWAY               | 63,677.10   | 12.060 |
| BRIDGES               | 329.42      | 0.062  |
| NET LENGTH OF PROJ.   | 64,006.52   | 12.122 |
| EXCEPTIONS            |             |        |
| GROSS LENGTH OF PROJ. | 64,006.52   | 12.122 |

| KEY SHEET REVISIONS |                                     |
|---------------------|-------------------------------------|
| DATE                | DESCRIPTION                         |
| 3-07                | Revised sequence of contract plans. |

ROADWAY PLANS  
ENGINEER OF RECORD: \_\_\_\_\_

P.E. NO. : \_\_\_\_\_

| FISCAL YEAR | SHEET NO. |
|-------------|-----------|
|             |           |

FDOT PROJECT MANAGER :

ELECTRONIC SIGNATURE NOTE WHEN SHEET IS ELECTRONICALLY SIGNED AND SEALED



## Chapter 5

# Drainage Map and Bridge Hydraulic Recommendation Sheet

|             |  |     |
|-------------|--|-----|
| 5.1         | Drainage Map.....  | 5-1 |
| 5.1.1       | Plan Portion .....   | 5-2 |
| 5.1.2       | Profile Portion .....  | 5-3 |
| 5.1.3       | Flood Data Summary Box .....   | 5-4 |
| 5.1.4       | Interchange Drainage Map .....   | 5-4 |
| 5.2         | Bridge Hydraulic Recommendation Sheet .....  | 5-5 |
| 5.2.1       | Required Information on BHRS.....  | 5-5 |
| 5.2.1.1     | Plan View .....  | 5-6 |
| 5.2.1.2     | Profile View .....   | 5-6 |
| 5.2.1.3     | Location Map and Drainage Area .....   | 5-7 |
| 5.2.1.4     | Existing Structures Data, Hydraulic Design<br>Data and Hydraulic Recommendations ..... | 5-7 |
| Exhibits    |  |     |
| Exhibit 5-1 | Drainage Map Notes .....   | 5-9 |

**THIS PAGE LEFT BLANK INTENTIONALLY**

## Chapter 5

# Drainage Map and Bridge Hydraulic Recommendation Sheet

### 5.1 Drainage Map

When a drainage map is required (see FDOT *Drainage Manual, Topic No. 625-040-002*) it shall be prepared and included in the project file. Inclusion of a drainage map in the contract plans set is optional at the district's discretion.

Preformatted drainage map sheet cells are located in the FDOT Engineering/CADD Systems Software. The upper (grid) portion of each sheet is used for plotting the project profile, which is optional at the discretion of the district. The standard grid pattern for the profile portion of the sheet is five lines per inch, both in the horizontal and vertical. This will accommodate most scales. An optional grid with four lines per inch is available. This sheet may be used if approved by the district.

Topography of the project area shall be located in the remaining portion of the sheet. Aerial photography may be used to develop a drainage map but must not be used in the contract plans set.

The horizontal and vertical scales of the profile should be such that the stations and elevations can be read directly from the grid without the use of a scale. The horizontal scale must be the same for both the plan and profile views. Recommended scales for facility types are as follows:

| <u>Type of Facility</u>  | <u>Horizontal Scale</u> | <u>Vertical Scale</u> |
|--------------------------|-------------------------|-----------------------|
| Interstate Urban         | 1" = 500'               | 1" = 5'/1"=10'        |
| Interstate & Other Rural | 1"=1000'/2000'          | 1" = 10'/1"=20'       |
| Municipal & Other        | 1"=200'/500'            | 1"= 5'/1" =10'        |

## 5.1.1 Plan Portion

The plan portion shall comply with the following requirements:

1. Stationing shall be shown every 500 feet for scales of 1" = 100'/200', every 1000 feet for a scale of 1" = 500' and every 5000 feet for scales of 1" = 1000'/2000'. For additional information see **Figure 10.1** in **Chapter 10** of this volume.

Station equations and exceptions shall be shown. Begin and end stations of project, construction, bridge and bridge culverts shall also be shown.

2. Existing physical land features affecting drainage, such as lakes, streams and swamps, shall be clearly labeled by name and direction of flow. Past high water elevations and date of occurrence, if available, and present water elevations along with the dates the readings were taken shall be shown.

Drainage divides and other information (such as pop-off elevations and spot elevations) shall be shown, where applicable, to indicate the overland flow of water. Drainage areas on maps shall be shown in acres.

Inserts shall be used to show areas that are of such magnitude that the boundaries cannot be plotted at the selected scale.

3. Existing road numbers and street names, drainage structures with type, size, flow line elevations, flow arrows and any other pertinent data shall be shown. Refer to the FDOT Engineering/CADD Systems Software and the **Design Standards, Index No. 002** for correct symbols for existing drainage facilities. In a situation of limited space, all data relating to existing drainage structures and pipes may be compiled in a table format and shown in either the plan or profile portion of the sheet. Should the space limitations be such that a table will not fit within the plan or profile view, a supplemental drainage data sheet is acceptable.
4. Proposed drainage structures, pipes, outfall structures and retention/detention pond locations, shall be shown. Structures and pipes shall be noted by structure number, and ponds by pond number. Arrows shall be shown to indicate direction of flow along proposed ditches.
5. Section, Township, Range and county lines shall be indicated for rural and urban projects when occurring within the project limits.
6. A north arrow and scale shall be shown, preferably in the upper right corner of the plan view.
7. If the drainage map is to be included in the contract plans set, include Note No. 1 (see **Exhibit 5-1**).

## 5.1.2 Profile Portion

The profile portion, if shown, shall comply with the following requirements:

1. The recommended vertical scale for rural and urban projects is 1" = 5' in level terrain and 1" = 10' in rolling terrain. A scale of 1" = 20' may sometimes be used for rural projects through rough terrain to avoid numerous profile breaks. The profile can be broken for rolling terrain in urban areas. However, a scale of 1" = 20' should never be used at locations of proposed storm drain systems.
2. Elevation datum shall be shown at each side of the sheet. In cases where the profile block is insufficient and excess space is available on the plan portion of the sheet, the profile block may be expanded.
3. The profile of the existing natural ground shall be plotted and labeled and the existing elevation noted at each end.
4. The proposed profile grade line shall be plotted. Percent of grade need not be shown. The PC, PI, and PT of vertical curves shall be plotted using their respective standard symbols; however, no data (station, elevation, length of curve) needs be noted. Begin and end project, bridge and bridge culvert stations, station equations and exceptions shall be flagged. Profile grade line elevations shall be shown at begin and end project stations and at the beginning and end of each additional drainage sheet.
5. Proposed cross drains shall be plotted and identified by structure number. Do not show skew or pipe slope in plotting, but plot to elevation and location at point of crossing the construction centerline.
6. For projects with storm drain systems, only the mainline structure and pipes shall be shown. Laterals need not be shown. Each structure shall be flagged with its appropriate structure number, and flow line elevations noted for the incoming and outgoing pipes.
7. All high water elevations affecting base clearance or roadway grades shall be shown.

### 5.1.3 Flood Data Summary Box

The flood data shall be shown on the drainage map, either in the plan or in the profile portion. If the drainage map is not included in the plans the flood data shall be shown on the summary of quantities sheet or on the first plan-profile sheet.

Design, base and overtopping or greatest flood discharge and stage values are required for all cross structures (culverts and bridges), regardless of size, under the following conditions:

1. All new cross structures
2. All cross structures that are being modified (extended, new end section, replaced, etc.)
3. All cross structures that have a history of flooding or other hydraulic problems, even if the structure is not to be modified; or
4. Cross structures that are not being modified but are being impacted by the modification of another cross structure within the same drainage basin.

A "disclaimer" and definitions are required to avoid misuse and possible responsibility for changes in the flood information values over which the FDOT has no control (see **Exhibit 5-1**). A preformatted summary box with disclaimer and definitions is located in the FDOT Engineering/CADD Systems Software.

The project drainage engineer shall provide the information required to complete the box.

### 5.1.4 Interchange Drainage Map

If projects include interchanges or rest areas, a drainage map on a 1" = 200' or 1" = 500' scale shall be included. The purpose of this detail is to show the small areas needed to calculate pipe sizes for the tabulation of drainage structures within these special areas. Should major drains pass through one of these areas, a cross reference note should indicate the proper sheet which reflects the drainage area for that through-structure.

## 5.2 Bridge Hydraulic Recommendation Sheet

When a Bridge Hydraulic Recommendation Sheet (BHRS) is required (see FDOT *Drainage Manual, Topic No. 625-040-002*), it shall be prepared on a preformatted sheet. The cell for this sheet is located in the FDOT Engineering/CADD Systems Software.

The inclusion of this sheet in the plans set is optional at the discretion of the district. When included in the plans, the BHRS shall be placed in the structures plans. If the BHRS is not included in the plans, sufficient details to show the location and extent of bottom and slope protection shall be contained in the plans.

Parallel (dual) bridges may be shown on one sheet, although a second sheet should be used, if necessary, to clearly convey the fit of the bridge to the stream bank. When two sheets are used, only the plan and profile information needs to be furnished on the second sheet.

A completed Bridge Hydraulic Recommendation Sheet is shown as *Exhibit BHD-1*.

### 5.2.1 Required Information on BHRS

The preformatted BHRS is divided into the four regions listed below. The required information for each region is described in the following sections.

1. Plan View
2. Profile View
3. Location Map and Drainage Area
4. Existing Structures, Hydraulic Design Data and Hydraulic Recommendations

### **5.2.1.1 Plan View**

1. Stationing, scale, and north arrow.
2. Existing topography (i.e., Including existing bridge) and contours (i.e., show elevations). Sufficient detail shall be shown in the vicinity of the proposed bridge to depict how the structure will tie to natural ground.
3. Label the name of the water body (i.e., St. Johns River).
4. Arrows showing the direction of the flow.
5. Proposed bridge begin and end station.
6. Limits of riprap.

### **5.2.1.2 Profile View**

1. Stationing and scale.
2. One cross section which most represents the section at the proposed crossing.
3. Road profile for the proposed structure (i.e., stationing and elevation).
4. Proposed bridge with low member, and pier locations (when practical).
5. Abutment locations (i.e., toe of slope).
6. Flood elevations. For non-tidal crossings, the Normal High Water (NHW) and Design Flood elevations shall be shown. For tidal crossings, the Mean High Water (MHW) and Design Flood Stage elevations shall be shown.
7. Present water elevation with month, day and year of survey.
8. Bridge Number. The bridge number should be for the new (proposed) structure.

### 5.2.1.3 Location Map and Drainage Area

1. A north arrow.
2. The range and township.
3. An arrow showing the project location.
4. A location map similar to that used on the key sheet for most projects. The map shall be of a scale so that the entire drainage area for the proposed structure is shown. (For projects with very large drainage areas, the map shall be of a scale that clearly shows the project location rather than a scale that shows the entire drainage area).

The drainage area boundaries shall be shown using a very heavy, broken line, with the area (in acres or square miles) shown within the boundary. The proposed structure location should be shown. Existing structures over the same water body and those structures that affect the hydraulics of the proposed structure should be located and numbered and corresponding existing structure information listed in the appropriate columns.

### 5.2.1.4 Existing Structures Data, Hydraulic Design Data and Hydraulic Recommendations

The ***Cross Drain Handbook*** provides guidance for filling out this section. Updated guidance will soon be found in the new ***BHR Handbook*** (which was not available at the time of this publication).

**THIS PAGE LEFT BLANK INTENTIONALLY**

### **Exhibit 5-1 Drainage Map Notes**

Below are standard notes which shall be placed on the drainage map as applicable.

1. (To be placed on the drainage map when it is to be included in the plans):  
*DO NOT USE THE INFORMATION ON THIS SHEET FOR CONSTRUCTION PURPOSES. This sheet is in the plans for documentation and to assist construction personnel with drainage concerns.*
2. (To be placed under Flood Data Box):  
Note: The hydraulic data is shown for informational purposes only, to indicate the flood discharges and water surface elevations which may be anticipated in any given year. This data was generated using highly variable factors determined by a study of the watershed. Many judgments and assumptions are required to establish these factors. The resultant hydraulic data is sensitive to changes, particularly of antecedent conditions, urbanization, channelization and land use. Users of this data are cautioned against the assumption of precision which can not be attained. Discharges are in cubic feet per second (cfs) and stages are in feet, NAVD 88.

**THIS PAGE LEFT BLANK INTENTIONALLY**

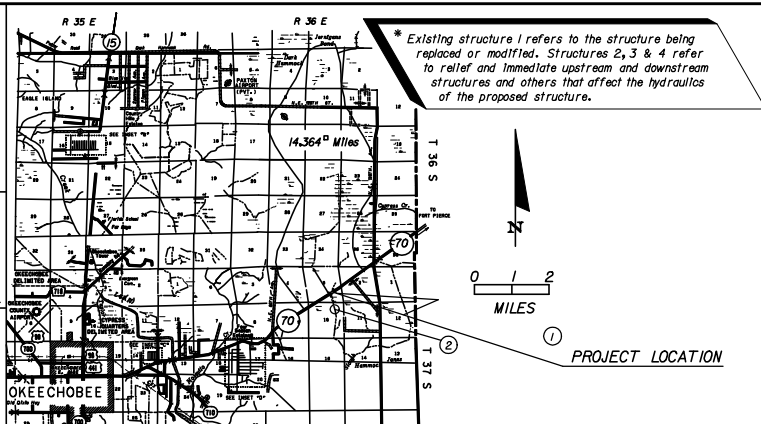
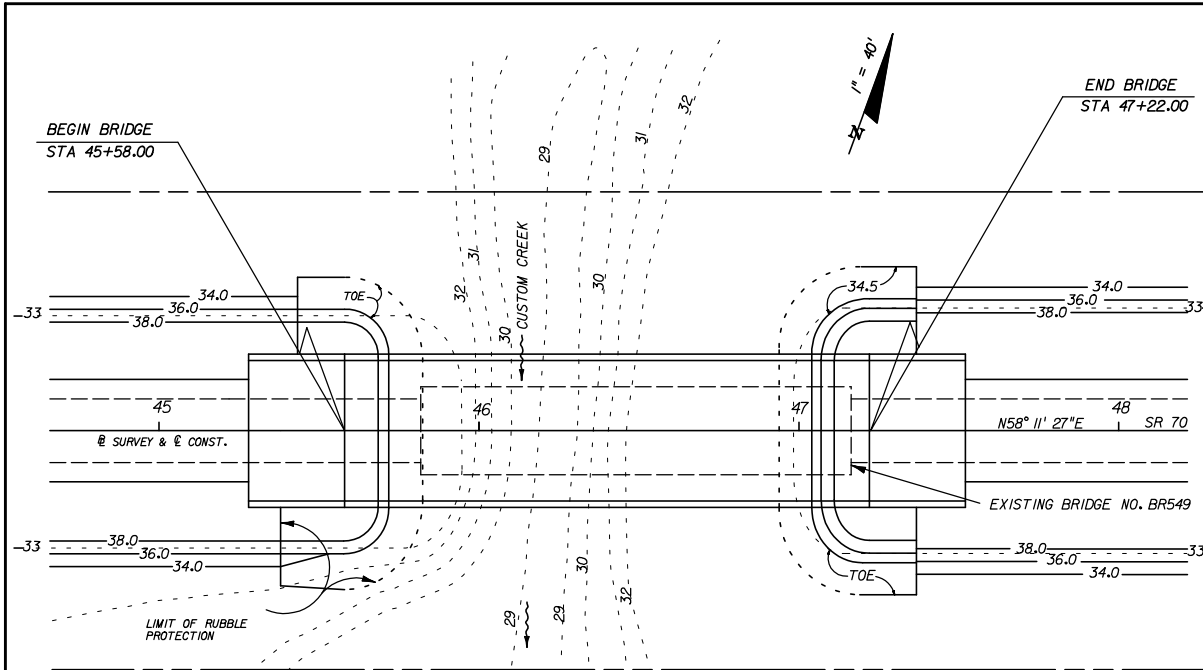

| (REFERENCE)            | (1)         | (2)              | (3) | (4) | PROPOSED STRUCTURE |
|------------------------|-------------|------------------|-----|-----|--------------------|
| FOUNDATION             | Conc. Piles | Timber           |     |     | Conc. Piles        |
| OVERALL LENGTH         | 135         | 200              |     |     | 164 (rem. #4)      |
| SPAN LENGTH            | 5 @ 27      | 20 @ 10          |     |     | 4 @ 41             |
| TYPE CONSTRUCTION      | Concrete    | Timber           |     |     | Concrete           |
| AREA OF OPENING @ D.F. | 1000        | Unknown          |     |     | 1020               |
| BRIDGE WIDTH           | 28'         | Railroad (South) |     |     | 44'                |
| ELEV. LOW MEMBER       | 40.35       | 38.32            |     |     | 41.17              |

**HYDRAULIC DESIGN DATA**

**NOTE:**  
The hydraulic data is shown for informational purposes only to indicate the flood discharges and water surface elevations which may be anticipated in any given year. This data was generated using highly variable factors determined by a study of the watershed. Many judgements and assumptions are required to establish these factors. The resultant hydraulic data is sensitive to changes, particularly antecedent conditions, urbanization, channelization and land use. Users of this data are cautioned against the assumption of precision which cannot be obtained.

**TERMS:**  
**Design Flood:** Utilized to assure a desired level of hydraulic performance.  
**Base Flood:** Has a 1% chance of being exceeded in any given year (100 year frequency)  
**Overtopping Flood:** Causes flow over the highway, over a watershed divide, or thru emergency relief structures.  
**Greatest Flood:** The most severe that can be predicted where overtopping is not practicable.

|  | WATER SURFACE ELEVATIONS: |                | CONTROL (Non-Tidal) |  | M.H.W. (Tidal) |  |
|--|---------------------------|----------------|---------------------|--|----------------|--|
|  | N.H.W. (Non-Tidal)        | M.L.W. (Tidal) |                     |  |                |  |
|  | 31.80                     |                |                     |  |                |  |
|  |                           |                |                     |  |                |  |

| FLOOD DATA:             | MAX. EVENT OF RECORD | DESIGN FLOOD | BASE FLOOD | OVERTOPPING or GREATEST FLOOD |
|-------------------------|----------------------|--------------|------------|-------------------------------|
| STAGE ELEV. NAVD (ft)   | 38.7 (rem. #2)       | 38.91        | 39.27      | 39.57                         |
| DISCHARGE (cfs)         | unknown              | 3280         | 3950       | 4630                          |
| AVERAGE VELOCITY (ft/s) |                      | 3.22         | 3.58       | 4.13                          |
| EXCEEDANCE PROB. (%)    |                      | 2            | 1          | 0.2                           |
| FREQUENCY (yr.)         |                      | 50           | 100        | 500                           |

| SCOUR PREDICTIONS FOR PROPOSED STRUCTURE DESCRIBED ABOVE: |                  | TOTAL SCOUR ELEVATION |                                  |
|---|------------------|-----------------------|----------------------------------|
| NUMBERS   | PIER INFORMATION | LONG TERM SCOUR ELEV. | WORST CASE < 100 yr. FREQ. (yr.) |
| 2 & 3   | ** SIZE AND TYPE | N/A                   | 18.4                             |
| 4 (rem. #3)   | 24" Conc. Piles  | N/A                   | 27.6                             |
|   |                  |                       | 16.4                             |
|   |                  |                       | 25.6                             |

**HYDRAULIC RECOMMENDATIONS**

1. BEGIN BRIDGE STATION 45+58.00 END BRIDGE STATION 47+22.00 SKEW ANGLE 0°  
 2. CLEARANCE PROVIDED: NAV. HORIZ. 39.0 VERT. 8.04 ABOVE EL. 33.14 DRIFT: HORIZ. 39.0 VERT. 2.26 ABOVE EL. 38.91  
 3. MINIMUM CLEARANCE: NAV. HORIZ. 10.0 VERT. 6.0 ABOVE EL. 33.14 DRIFT: HORIZ. N/A VERT. 2.0 ABOVE EL. 38.91  
 4. ABUTMENTS: BEGIN BRIDGE END BRIDGE

\*\*\* RUBBLE GRADE: Bank and Shore  
 SLOPE: 1:2  
 BURIED OR NON-BURIED: Non-Buried  
 TOE HORIZ. DISTANCE: 10  
 LIMIT OF PROTECTION: 15' Lt., 20' Rt.

5. DECK DRAINAGE: Spread is contained in shoulder. Runoff captured by inlets at begin bridge.

**REMARKS:** (1) Bridge lengthened to accommodate predicted channel migration to the west.  
 (2) Based on mark provided by local resident of 43 years.  
 (3) Due to predicted channel migration to the west and lock of meander cutoff, Pier No. 4 will not experience main channel scour depths.

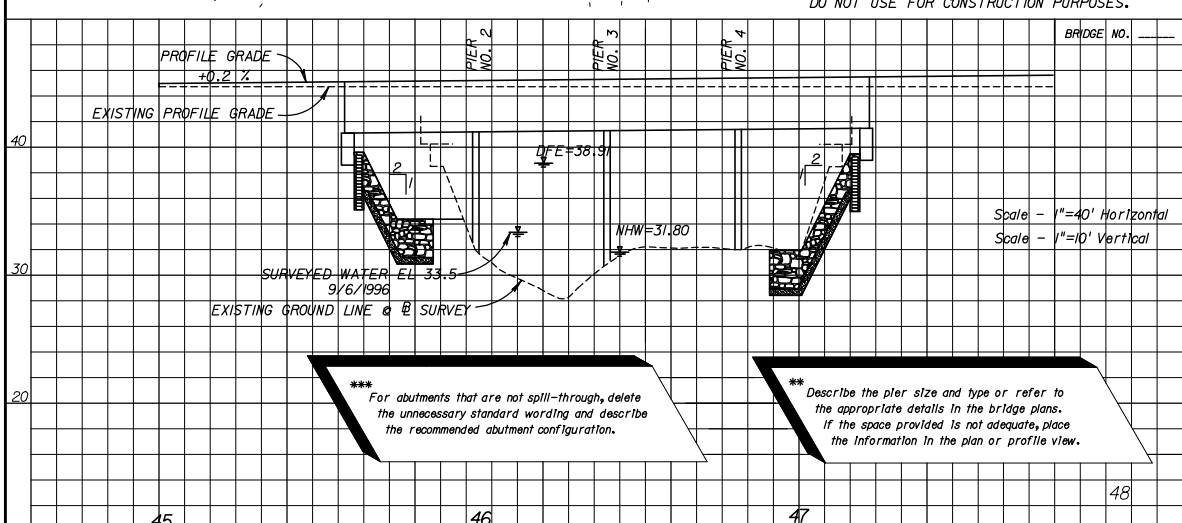

\*\*\* For abutments that are not spill-through, delete the unnecessary standard wording and describe the recommended abutment configuration.

\*\* Describe the pier size and type or refer to the appropriate details in the bridge plans. If the space provided is not adequate, place the information in the plan or profile view.

| REVISIONS |             |      |             |
|-----------|-------------|------|-------------|
| DATE      | DESCRIPTION | DATE | DESCRIPTION |
|           |             |      |             |

|  |        |                      |                                     |              |
|--|--------|----------------------|-------------------------------------|--------------|
| STATE OF FLORIDA<br>DEPARTMENT OF TRANSPORTATION |        |                      | BRIDGE HYDRAULIC<br>RECOMMENDATIONS | SHEET<br>NO. |
| ROAD NO.   | COUNTY | FINANCIAL PROJECT ID |                                     |              |
| 70   | LEON   | 123456-1-52-01       |                                     |              |

NOTICE: THE OFFICIAL RECORD OF THIS SHEET IS THE ELECTRONIC FILE SIGNED AND SEALED UNDER RULE 68G5-23.003, F.A.C.

**EXHIBIT BHD-1**  
Date: 1/1/08



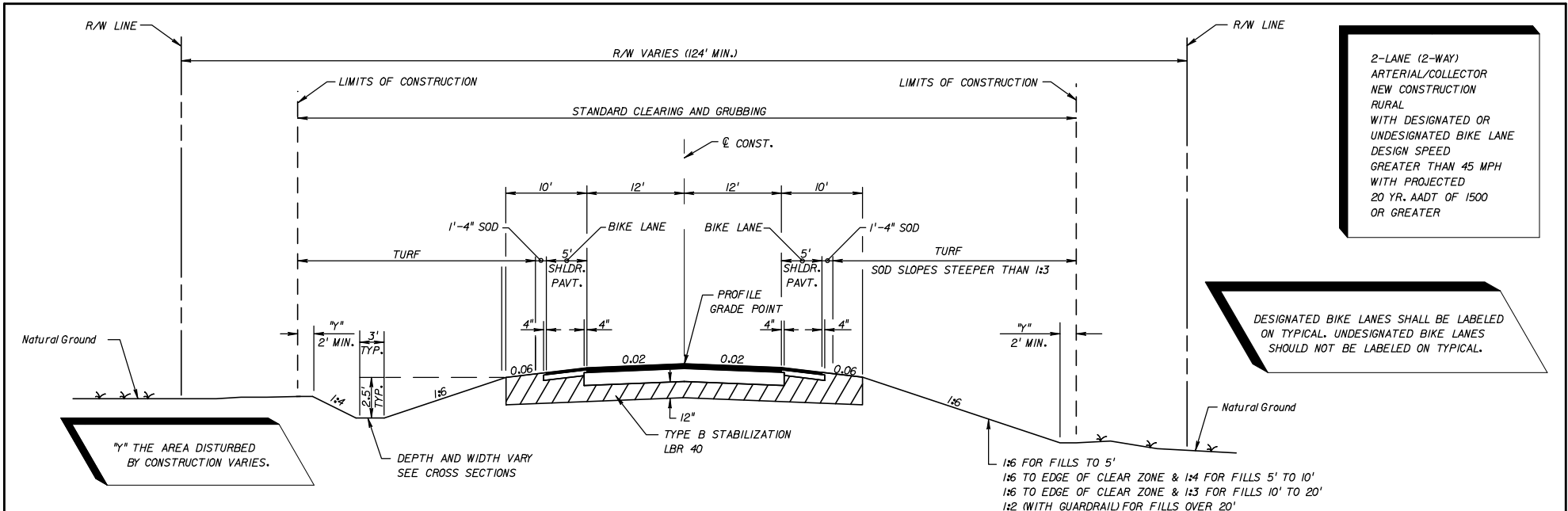

2-LANE (2-WAY)  
 ARTERIAL/COLLECTOR  
 NEW CONSTRUCTION  
 RURAL  
 WITH DESIGNATED OR  
 UNDESIGNATED BIKE LANE  
 DESIGN SPEED  
 GREATER THAN 45 MPH  
 WITH PROJECTED  
 20 YR. AADT OF 1500  
 OR GREATER

DESIGNATED BIKE LANES SHALL BE LABELED  
 ON TYPICAL. UNDESIGNATED BIKE LANES  
 SHOULD NOT BE LABELED ON TYPICAL.

**TYPICAL SECTION**  
**SR 10 (U.S. 90-A)**  
**STA. 10+00.00 TO STA. 267+34.89**

**TRAFFIC DATA**  
 CURRENT YEAR = 1998 AADT = 6800  
 ESTIMATED OPENING YEAR = 2000 AADT = 7600  
 ESTIMATED DESIGN YEAR = 2020 AADT = 12000  
 K = 6% D = 55% T = 2% (24 HOUR)  
 DESIGN HOUR T = 1%  
 DESIGN SPEED = 55 MPH

TRAFFIC DATA IS REQUIRED TO BE NOTED FOR  
 CURRENT YEAR, OPENING YEAR AND DESIGN YEAR.  
 POSTED SPEED (MPH) IS OPTIONAL.

FOR STANDARD TYPICAL SECTION NOTES  
 REFER TO EXHIBIT 6-1, THIS CHAPTER.

**NEW CONSTRUCTION**  
 OPTIONAL BASE GROUP 8 WITH  
 TYPE SP STRUCTURAL COURSE (TRAFFIC C) (2")  
 AND FRICTION COURSE FC-12.5 (TRAFFIC C) (1/2") (RUBBER)

**SHOULDER PAVEMENT**  
 OPTIONAL BASE GROUP 1 WITH  
 FRICTION COURSE FC-12.5 (TRAFFIC C) (1/2") (RUBBER)

**NOTE:**  
 HEIGHT OF FILL IS THE VERTICAL DISTANCE  
 FROM THE EDGE OF THE OUTSIDE TRAVEL LANE  
 TO TOE OF FRONT SLOPE.

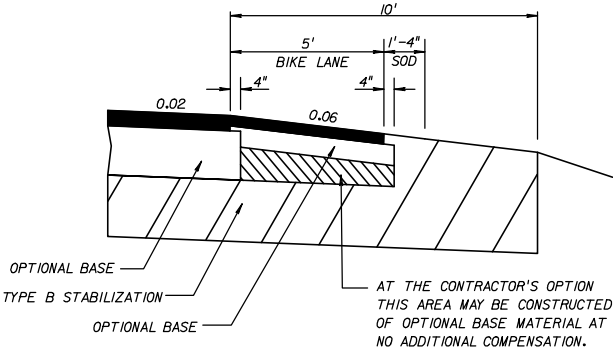

**SHOULDER PAVEMENT DETAIL**

**EXHIBIT TYP-1**  
 Date: 1/1/08

| REVISIONS |             |      |             | STATE OF FLORIDA<br>DEPARTMENT OF TRANSPORTATION |        |                      | TYPICAL SECTION | SHEET NO. |
|-----------|-------------|------|-------------|--|--------|----------------------|-----------------|-----------|
| DATE      | DESCRIPTION | DATE | DESCRIPTION | ROAD NO.   | COUNTY | FINANCIAL PROJECT ID |                 |           |
|           |             |      |             | LEON   |        | 123456-1-52-01       |                 |           |

#USERS #DATES #TIMES #FILES

NOTICE: THE OFFICIAL RECORD OF THIS SHEET IS THE ELECTRONIC FILE SIGNED AND SEALED UNDER RULE 6805-23.003, F.A.C.

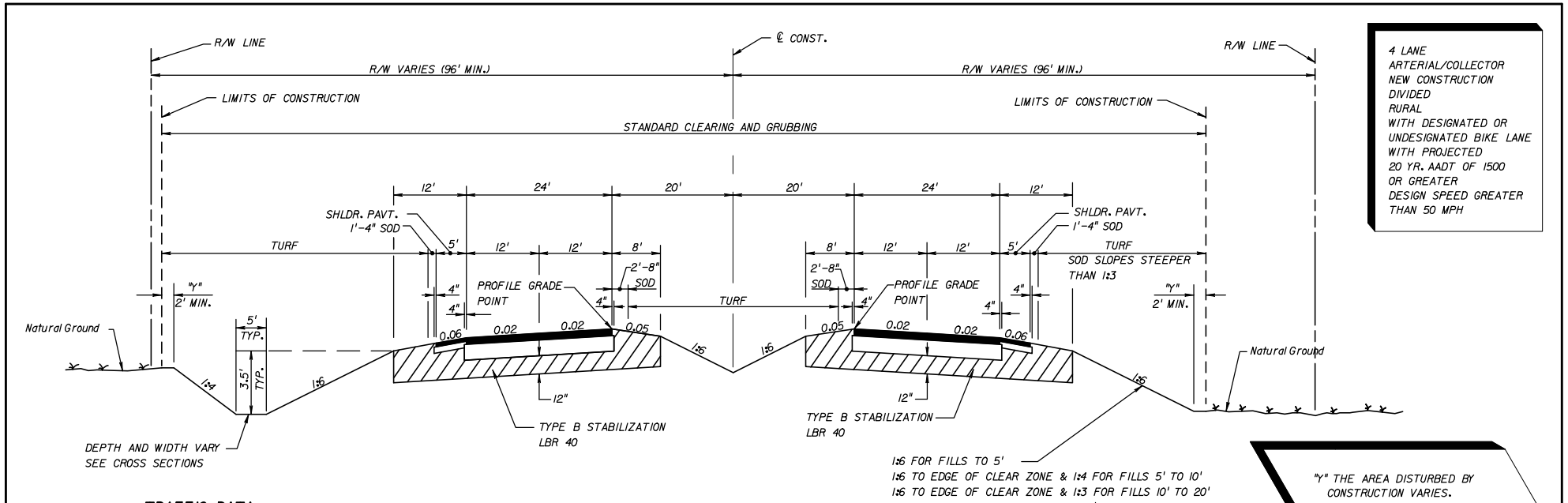

4 LANE  
ARTERIAL/COLLECTOR  
NEW CONSTRUCTION  
DIVIDED  
RURAL  
WITH DESIGNATED OR  
UNDESIGNATED BIKE LANE  
WITH PROJECTED  
20 YR. AADT OF 1500  
OR GREATER  
DESIGN SPEED GREATER  
THAN 50 MPH

**TRAFFIC DATA**

CURRENT YEAR = 1998 AADT = 22300  
ESTIMATED OPENING YEAR = 2000 AADT = 23300  
ESTIMATED DESIGN YEAR = 2020 AADT = 51500  
K = 9% D = 56% T = 10% (24 HOUR)  
DESIGN HOUR T = 5%  
DESIGN SPEED = 70 MPH

**TYPICAL SECTION  
SR 500  
STA. 63+65.42 TO STA. 328+65.14**

**NEW CONSTRUCTION**

OPTIONAL BASE GROUP 9 WITH  
TYPE SP STRUCTURAL COURSE (TRAFFIC D) (2")  
TYPE SP STRUCTURAL COURSE (TRAFFIC D) (1 1/2") (PG 76-22)  
AND FRICTION COURSE FC-5 (3/4") (PG 76-22)

**SHOULDER PAVEMENT**

OPTIONAL BASE GROUP 1 WITH  
TYPE SP STRUCTURAL COURSE (TRAFFIC D) (1 1/2") (PG 76-22)  
AND FRICTION COURSE FC-5 (3/4") (PG 76-22)

NOTE:  
HEIGHT OF FILL IS THE VERTICAL DISTANCE  
FROM THE EDGE OF THE OUTSIDE TRAVEL LANE  
TO TOE OF FRONT SLOPE.

DESIGNATED BIKE LANES SHALL BE LABELED  
ON TYPICAL. UNDESIGNATED BIKE LANES  
SHOULD NOT BE LABELED ON TYPICAL.

TRAFFIC DATA IS REQUIRED TO BE  
NOTED FOR CURRENT YEAR,  
OPENING YEAR, AND DESIGN YEAR.  
POSTED SPEED (MPH) IS OPTIONAL.

FOR STANDARD TYPICAL SECTION NOTES  
REFER TO EXHIBIT 6-1, THIS CHAPTER.

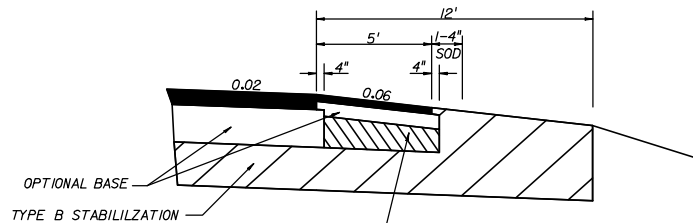

AT THE CONTRACTOR'S OPTION  
THIS AREA MAY BE CONSTRUCTED  
OF OPTIONAL BASE MATERIAL  
AT NO ADDITIONAL COMPENSATION

**SHOULDER PAVEMENT DETAIL**

EXHIBIT TYP-2  
Date: 1/1/08

| REVISIONS |             |      |             | STATE OF FLORIDA<br>DEPARTMENT OF TRANSPORTATION |        |                      | SHEET<br>NO. |
|-----------|-------------|------|-------------|--|--------|----------------------|--------------|
| DATE      | DESCRIPTION | DATE | DESCRIPTION | ROAD NO.   | COUNTY | FINANCIAL PROJECT ID |              |
|           |             |      |             | 10   | LEON   | 123456-1-52-01       |              |

**TYPICAL SECTION**

#USERS #DATES #TIMES #FILES

NOTICE: THE OFFICIAL RECORD OF THIS SHEET IS THE ELECTRONIC FILE SIGNED AND SEALED UNDER RULE 6805-23.003, F.A.C.

DESIGNATED BIKE LANES SHALL BE LABELED ON TYPICAL. UNDESIGNATED BIKE LANES SHOULD NOT BE LABELED ON TYPICAL.

5-LANE SECTIONS ARE TO INCLUDE SECTIONS OF RAISED OR RESTRICTIVE MEDIAN. SEE PPM TABLE 2.2.1.

5-LANE ARTERIAL/COLLECTOR NEW CONSTRUCTION UNDIVIDED URBAN WITH DESIGNATED OR UNDESIGNATED BIKE LANE MINIMUM RIGHT OF WAY DESIGN SPEED 40 MPH OR LESS WITH PROJECTED 20 YR. AADT OF 1500 OR GREATER

\*\* IF LIMITS OF CONSTRUCTION EXCEEDS RIGHT OF WAY, A PROPERTY AGREEMENT IS REQUIRED.

\* TURF OR SOD

FOR STANDARD TYPICAL SECTION NOTES REFER TO EXHIBIT 6-1, THIS CHAPTER.

LIMITS OF CONSTRUCTION

LIMITS OF CONSTRUCTION

STANDARD CLEARING AND GRUBBING

\*\* VARIES

VARIES \*\*

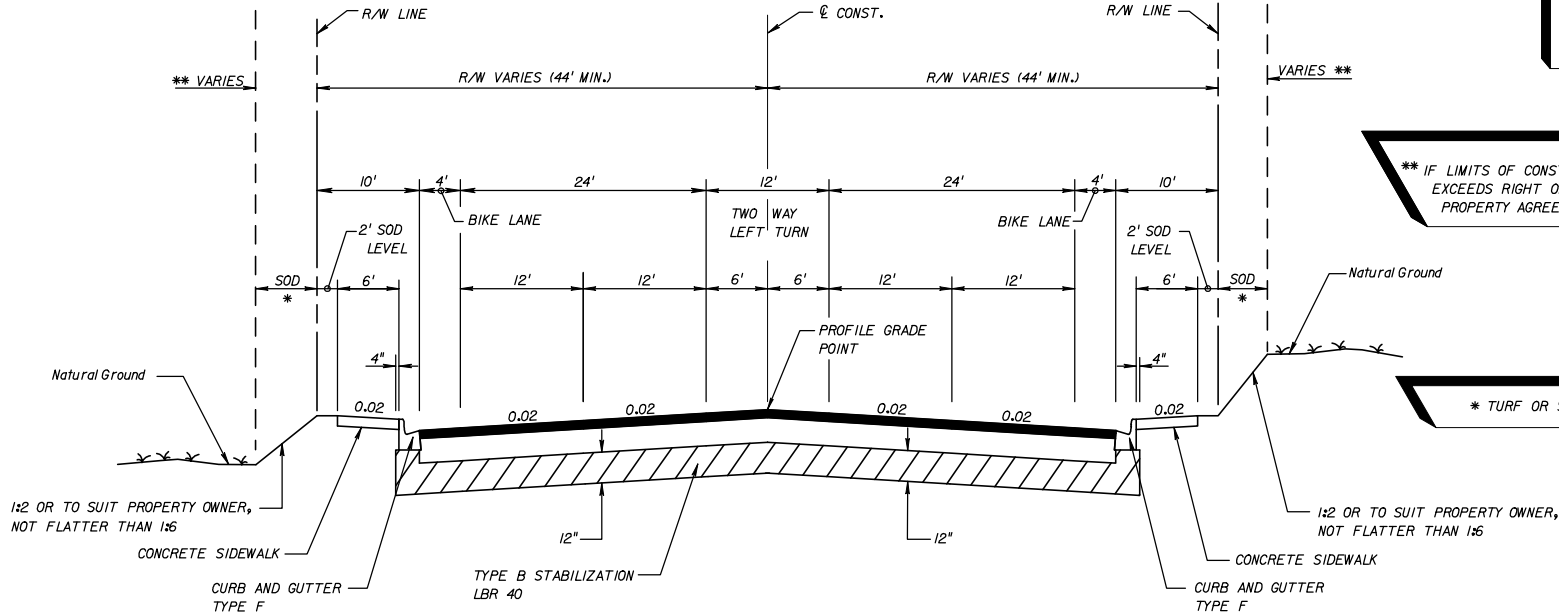

**TRAFFIC DATA**

CURRENT YEAR = 1998 AADT = 9900  
 ESTIMATED OPENING YEAR = 2000 AADT = 10600  
 ESTIMATED DESIGN YEAR = 2020 AADT = 14000  
 K = 6% D = 55% T = 2% (24 HOUR)  
 DESIGN HOUR T = 1%  
 DESIGN SPEED = 40 MPH

**TYPICAL SECTION  
 SR 00 (DUVAL STREET)  
 STA. 252+12.00 TO STA. 323+19.42**

**NEW CONSTRUCTION**

OPTIONAL BASE GROUP 8 WITH  
 TYPE SP STRUCTURAL COURSE (TRAFFIC B) (1 1/2")  
 AND FRICTION COURSE FC-12.5 (TRAFFIC B) (1 1/2") (RUBBER)

TRAFFIC DATA IS REQUIRED TO BE NOTED FOR CURRENT YEAR, OPENING YEAR AND DESIGN YEAR. POSTED SPEED (MPH) IS OPTIONAL.

**EXHIBIT TYP-3**  
 Date: 1/1/08

| REVISIONS |             |      |             | STATE OF FLORIDA<br>DEPARTMENT OF TRANSPORTATION |        |                      | SHEET NO. |
|-----------|-------------|------|-------------|--|--------|----------------------|-----------|
| DATE      | DESCRIPTION | DATE | DESCRIPTION | ROAD NO.   | COUNTY | FINANCIAL PROJECT ID |           |
|           |             |      |             | 10   | LEON   | 123456-1-52-01       |           |

**TYPICAL SECTION**

#USERS #DATES #TIMES #FILES

NOTICE: THE OFFICIAL RECORD OF THIS SHEET IS THE ELECTRONIC FILE SIGNED AND SEALED UNDER RULE 6805-23.003, F.A.C.

DESIGNATED BIKE LANES SHALL BE LABELED ON TYPICAL. UNDESIGNATED BIKE LANES SHOULD NOT BE LABELED ON TYPICAL.

5-LANE SECTIONS ARE TO INCLUDE SECTIONS OF RAISED OR RESTRICTIVE MEDIAN. SEE PPM TABLE 2.2.J.

5-LANE ARTERIAL/COLLECTOR NEW CONSTRUCTION UNDIVIDED URBAN WITH DESIGNATED OR UNDESIGNATED BIKE LANE DESIGN SPEED 40 MPH OR LESS WITH PROJECTED 20 YR. AADT OF 1500 OR GREATER

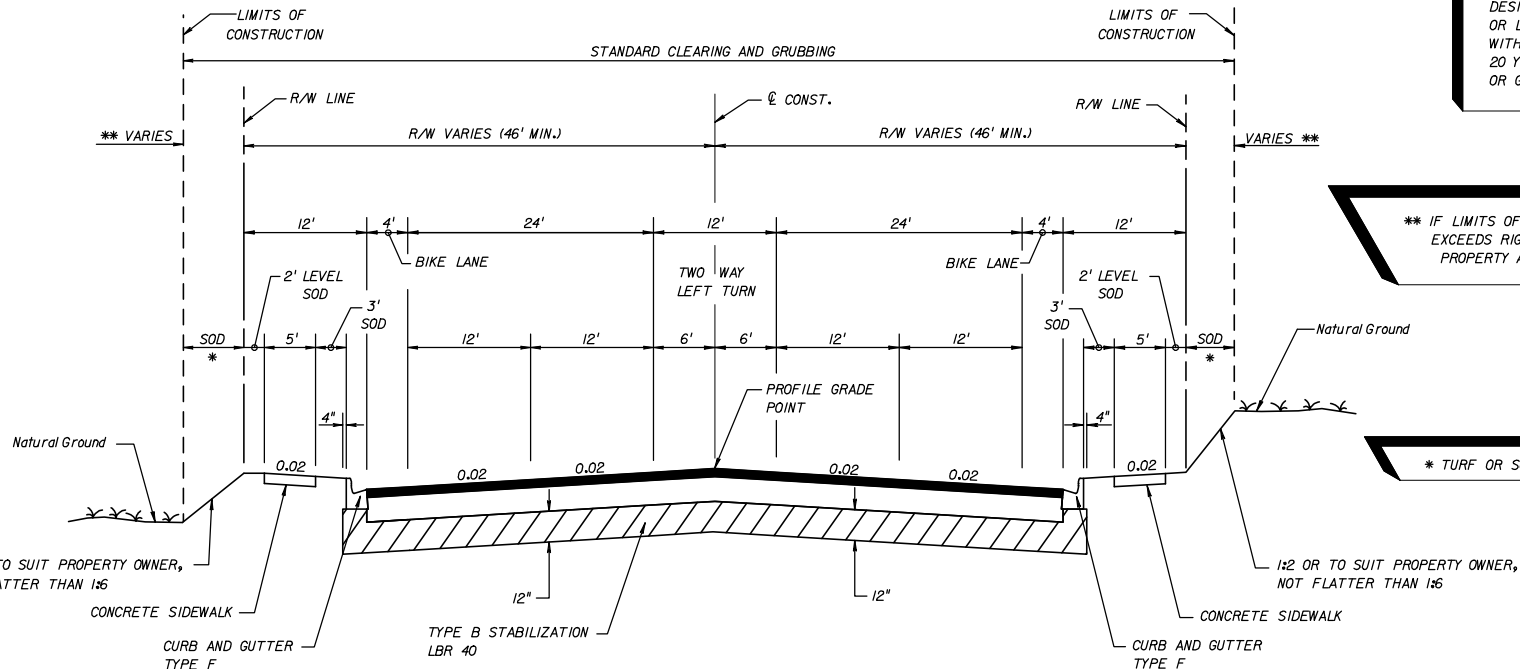

\*\* IF LIMITS OF CONSTRUCTION EXCEEDS RIGHT OF WAY, A PROPERTY AGREEMENT IS REQUIRED.

\* TURF OR SOD

1:2 OR TO SUIT PROPERTY OWNER, NOT FLATTER THAN 1:6

1:2 OR TO SUIT PROPERTY OWNER, NOT FLATTER THAN 1:6

**TRAFFIC DATA**

CURRENT YEAR = 1998 AADT = 20819  
 ESTIMATED OPENING YEAR = 2003 AADT = 24100  
 ESTIMATED DESIGN YEAR = 2023 AADT = 24900  
 K = 9% D = 60% T = 2% (24 HOUR)  
 DESIGN HOUR T = 1%  
 DESIGN SPEED = 40 MPH

TRAFFIC DATA IS REQUIRED TO BE NOTED FOR CURRENT YEAR, OPENING YEAR AND DESIGN YEAR. POSTED SPEED (MPH) IS OPTIONAL.

**TYPICAL SECTION  
 SR 00 (MATTHEWS STREET)  
 STA. 202+42.00 TO STA. 263+29.68**

**NEW CONSTRUCTION**

OPTIONAL BASE GROUP 8 WITH  
 TYPE SP STRUCTURAL COURSE (TRAFFIC B) (1/2")  
 AND FRICTION COURSE FC-12.5 (TRAFFIC B) (1/2") (RUBBER)

FOR STANDARD TYPICAL SECTION NOTES REFER TO EXHIBIT 6-1, THIS CHAPTER.

EXHIBIT TYP-4  
 Date: 1/1/08

| REVISIONS |             | STATE OF FLORIDA<br>DEPARTMENT OF TRANSPORTATION |             |                        | SHEET<br>NO. |
|-----------|-------------|--|-------------|------------------------|--------------|
| DATE      | DESCRIPTION | DATE   | DESCRIPTION | FINANCIAL PROJECT ID   |              |
|           |             |  |             | 10 LEON 123456-1-52-01 |              |

**TYPICAL SECTION**

#USERS #DATES #TIMES #FILES

NOTICE: THE OFFICIAL RECORD OF THIS SHEET IS THE ELECTRONIC FILE SIGNED AND SEALED UNDER RULE 6805-23.003, F.A.C.

DESIGNATED BIKE LANES SHALL BE LABELED ON TYPICAL. UNDESIGNATED BIKE LANES SHOULD NOT BE LABELED ON TYPICAL.

4-LANE ARTERIAL NEW CONSTRUCTION DIVIDED URBAN WITH DESIGNATED OR UNDESIGNATED BIKE LANE DESIGN SPEED 45 MPH OR LESS

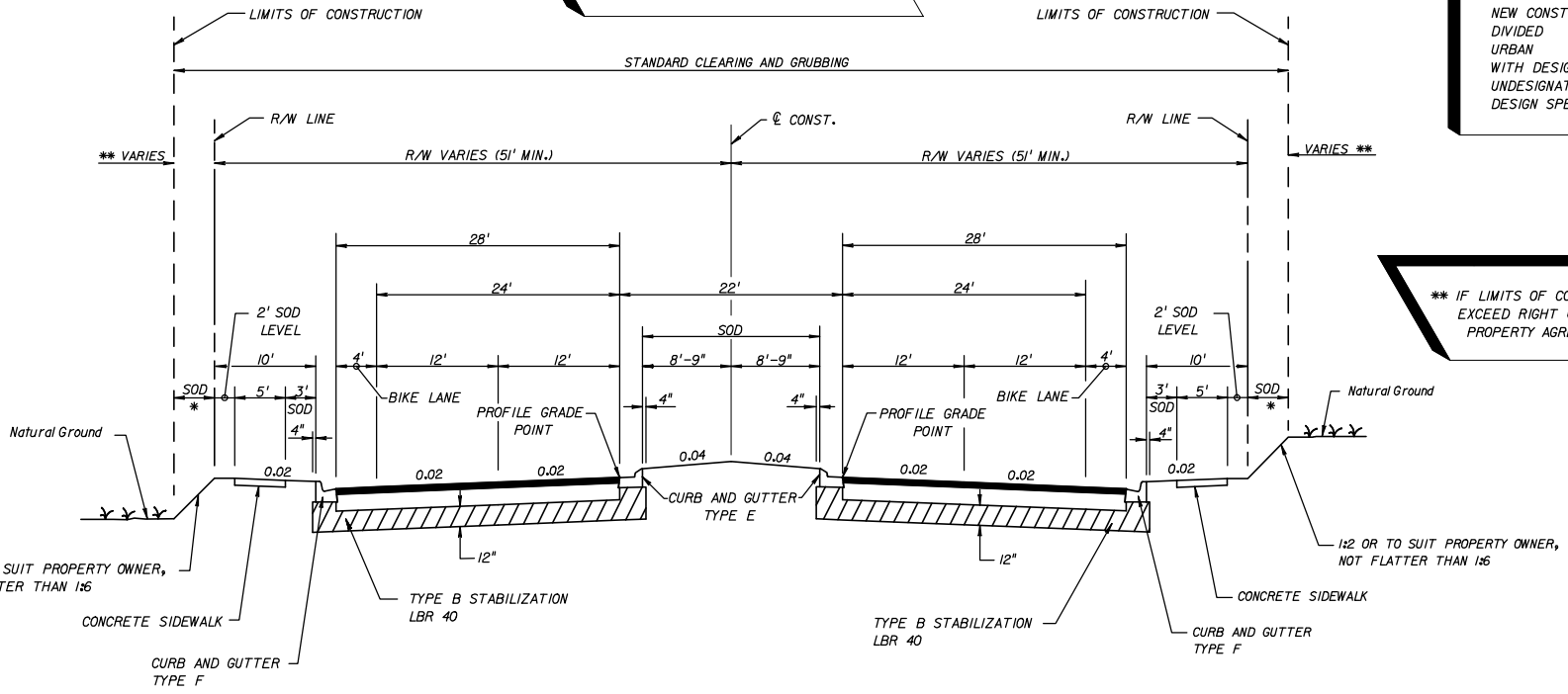

\*\* IF LIMITS OF CONSTRUCTION EXCEED RIGHT OF WAY, A PROPERTY AGREEMENT IS REQUIRED.

**TYPICAL SECTION  
SR 00 (WILSON STREET)  
STA. 98+40.00 TO STA. 202+33.00**

**NEW CONSTRUCTION**

OPTIONAL BASE GROUP 9 WITH  
TYPE SP STRUCTURAL COURSE (TRAFFIC B) (1 1/2")  
AND FRICTION COURSE FC-12.5 (TRAFFIC B) (1 1/2") (RUBBER)

\* TURF OR SOD

FOR STANDARD TYPICAL SECTION NOTES REFER TO EXHIBIT 6-1, THIS CHAPTER.

**EXHIBIT TYP-5**  
Date: 1/1/08

**TRAFFIC DATA**

CURRENT YEAR = 1998 AADT = 22800  
ESTIMATED OPENING YEAR = 2000 AADT = 25800  
ESTIMATED DESIGN YEAR = 2020 AADT = 30600  
K = 6% D = 55% T = 2% (24 HOUR)  
DESIGN HOUR T = 1%  
DESIGN SPEED = 45 MPH

TRAFFIC DATA IS REQUIRED TO BE NOTED FOR CURRENT YEAR, OPENING YEAR AND DESIGN YEAR. POSTED SPEED (MPH) IS OPTIONAL.

**REVISIONS**

| DATE | DESCRIPTION | DATE | DESCRIPTION |
|------|-------------|------|-------------|
|      |             |      |             |

**STATE OF FLORIDA  
DEPARTMENT OF TRANSPORTATION**

| ROAD NO. | COUNTY | FINANCIAL PROJECT ID |
|----------|--------|----------------------|
| 10       | LEON   | 123456-1-52-01       |

**TYPICAL SECTION**

SHEET NO.

NOTICE: THE OFFICIAL RECORD OF THIS SHEET IS THE ELECTRONIC FILE SIGNED AND SEALED UNDER RULE 6805-23.003, F.A.C.

DESIGNATED BIKE LANES SHALL BE LABELED ON TYPICAL. UNDESIGNATED BIKE LANES SHOULD NOT BE LABELED ON TYPICAL.

\*\* IF LIMITS OF CONSTRUCTION EXCEED RIGHT OF WAY, A PROPERTY AGREEMENT IS REQUIRED.

6-LANE ARTERIAL NEW CONSTRUCTION DIVIDED URBAN WITH DESIGNATED OR UNDESIGNATED BIKE LANE DESIGN SPEED 45 MPH OR LESS

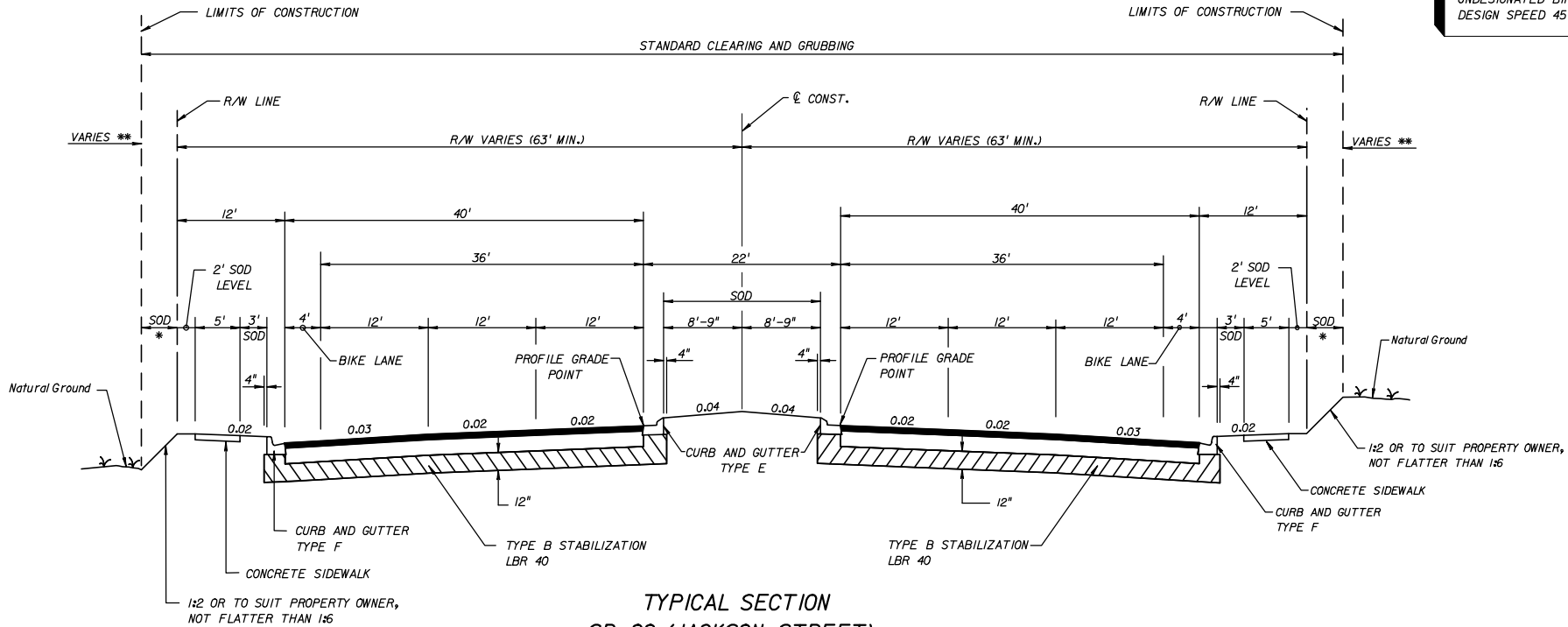

TYPICAL SECTION  
SR 00 (JACKSON STREET)  
STA. 101+21.00 TO STA. 221+44.00

NEW CONSTRUCTION

OPTIONAL BASE GROUP 9 WITH  
TYPE SP STRUCTURAL COURSE (TRAFFIC C) (2")  
AND FRICTION COURSE FC-12.5 (TRAFFIC C) (1 1/2") (RUBBER)

TRAFFIC DATA

CURRENT YEAR = 1998 AADT = 22800  
ESTIMATED OPENING YEAR = 2000 AADT = 25800  
ESTIMATED DESIGN YEAR = 2020 AADT = 30600  
K = 6% D = 55% T = 2% (24 HOUR)  
DESIGN HOUR T = 1%  
DESIGN SPEED = 45 MPH

TRAFFIC DATA IS REQUIRED TO BE NOTED FOR CURRENT YEAR, OPENING YEAR AND DESIGN YEAR.

\* TURF OR SOD

FOR STANDARD TYPICAL SECTION NOTES REFER TO EXHIBIT 6-1, THIS CHAPTER.

EXHIBIT TYP-6  
Date: 1/1/08

| REVISIONS |             | DESCRIPTION |             | STATE OF FLORIDA<br>DEPARTMENT OF TRANSPORTATION |        |                      | SHEET NO. |
|-----------|-------------|-------------|-------------|--|--------|----------------------|-----------|
| DATE      | DESCRIPTION | DATE        | DESCRIPTION | ROAD NO.   | COUNTY | FINANCIAL PROJECT ID |           |
|           |             |             |             | 10   | LEON   | 123456-1-52-01       |           |

TYPICAL SECTION

#USERS #DATES #TIMES #FILES

NOTICE: THE OFFICIAL RECORD OF THIS SHEET IS THE ELECTRONIC FILE SIGNED AND SEALED UNDER RULE 6805-23.003, F.A.C.

DESIGNATED BIKE LANES SHALL BE LABELED ON TYPICAL. UNDESIGNATED BIKE LANES SHOULD NOT BE LABELED ON TYPICAL.

\*\* IF LIMITS OF CONSTRUCTION EXCEED RIGHT OF WAY, A PROPERTY AGREEMENT IS REQUIRED.

6-LANE ARTERIAL NEW CONSTRUCTION DIVIDED URBAN WITH DESIGNATED OR UNDESIGNATED BIKE LANE DESIGN SPEED 45 MPH OR LESS

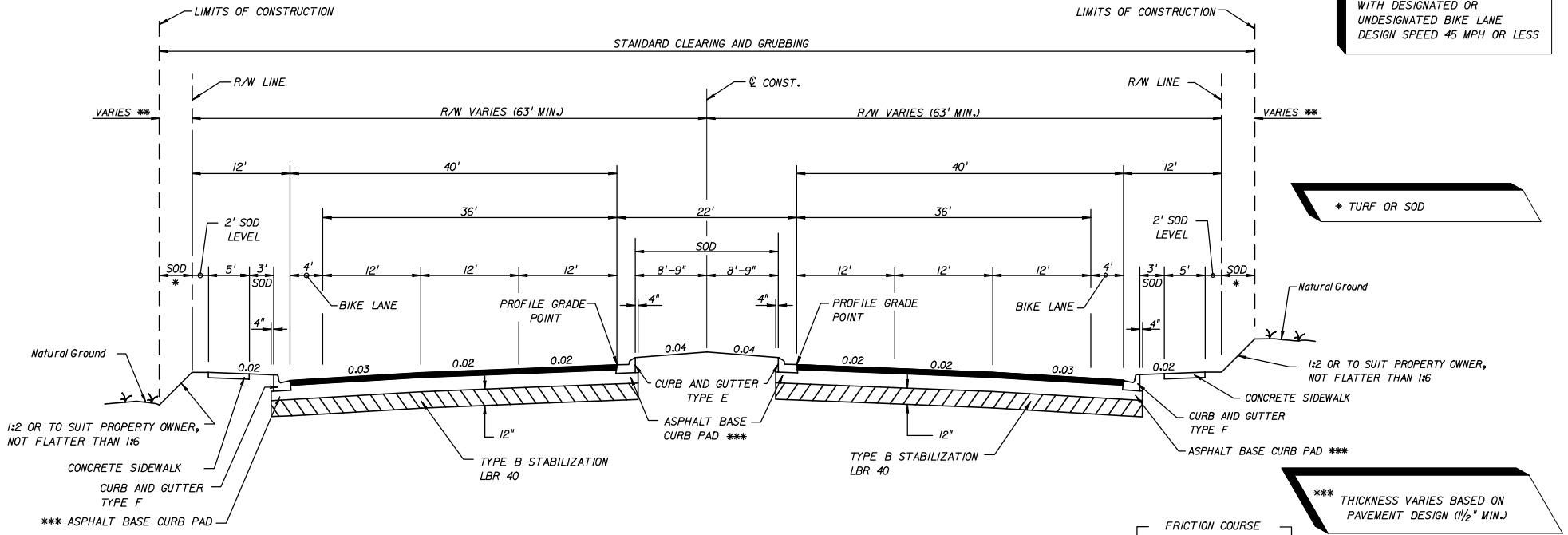

1:2 OR TO SUIT PROPERTY OWNER, NOT FLATTER THAN 1:6  
CONCRETE SIDEWALK  
CURB AND GUTTER TYPE F  
\*\*\* ASPHALT BASE CURB PAD

1:2 OR TO SUIT PROPERTY OWNER, NOT FLATTER THAN 1:6  
CONCRETE SIDEWALK  
CURB AND GUTTER TYPE F  
\*\*\* ASPHALT BASE CURB PAD

**TRAFFIC DATA**

CURRENT YEAR = 1998 AADT = 22800  
ESTIMATED OPENING YEAR = 2000 AADT = 25800  
ESTIMATED DESIGN YEAR = 2020 AADT = 30600  
K = 6% D = 55% T = 2% (24 HOUR)  
DESIGN HOUR T = 1%  
DESIGN SPEED = 45 MPH

**TYPICAL SECTION  
SR 00 (JACKSON STREET)  
STA. 101+21.00 TO STA. 221+44.00**

**NEW CONSTRUCTION**

OPTIONAL BASE GROUP 9 (TYPE B-12.5 ONLY), WITH TYPE SP STRUCTURAL COURSE (TRAFFIC C) (3") AND FRICTION COURSE FC-12.5 (TRAFFIC C) (1/2") (RUBBER)

FOR STANDARD TYPICAL SECTION NOTES REFER TO EXHIBIT 6-1, THIS CHAPTER

TRAFFIC DATA IS REQUIRED TO BE NOTED FOR CURRENT YEAR, OPENING YEAR AND DESIGN YEAR.

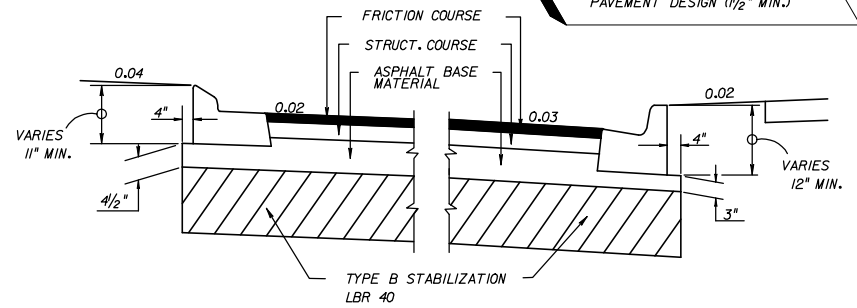

DETAIL OF ASPHALT BASE CURB PAD

**EXHIBIT TYP-6A**  
Date: 1/1/08

| REVISIONS |             | STATE OF FLORIDA<br>DEPARTMENT OF TRANSPORTATION |             |                        | SHEET NO. |
|-----------|-------------|--|-------------|------------------------|-----------|
| DATE      | DESCRIPTION | DATE   | DESCRIPTION | FINANCIAL PROJECT ID   |           |
|           |             |  |             | 10 LEON 123456-1-52-01 |           |

**TYPICAL SECTION**

#USERS #DATES #TIMES #FILES

NOTICE: THE OFFICIAL RECORD OF THIS SHEET IS THE ELECTRONIC FILE SIGNED AND SEALED UNDER RULE 6805-23.003, F.A.C.

DESIGNATED BIKE LANES SHALL BE LABELED ON TYPICAL, UNDESIGNATED BIKE LANES SHOULD NOT BE LABELED ON TYPICAL.

EXISTING 2-LANE (2-WAY) ARTERIAL/COLLECTOR MILLING AND RESURFACING NO CROSS SLOPE CORRECTION REQUIRED UNDIVIDED RURAL (WITH DESIGNATED OR UNDESIGNATED BIKE LANE EXISTING) WITH PROJECTED 20 YR. AADT OF 1500 OR GREATER

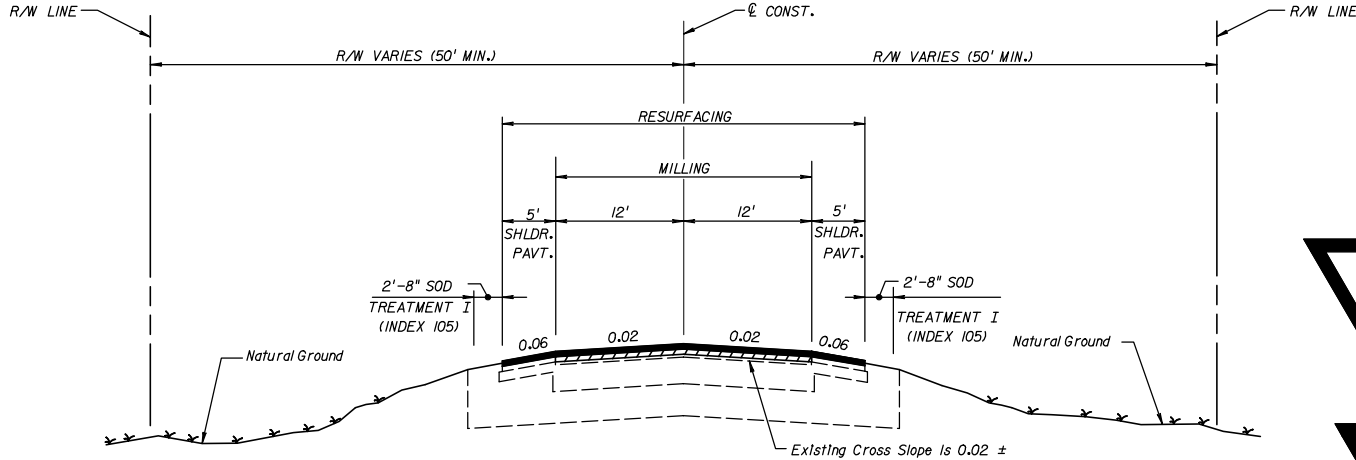

SOME PROJECTS MAY REQUIRE SHOULDER WORK. WHEN REQUIRED THIS SHOULD BE IDENTIFIED ON THE TYPICAL SECTION SHEET.

FOR STANDARD TYPICAL SECTION NOTES REFER TO EXHIBIT 6-1, THIS CHAPTER.

**TRAFFIC DATA**  
**STA. 10+53.00 TO STA. 130+77.00**

CURRENT YEAR = 1998 AADT = 9670  
ESTIMATED OPENING YEAR = 2000 AADT = 11900  
ESTIMATED DESIGN YEAR = 2010 AADT = 20200  
K = 10% D = 60% T = 7% (24 HOUR)  
DESIGN HOUR T = 3%  
DESIGN SPEED = 55 MPH

**TYPICAL SECTION**  
**SR 00**  
**STA. 10+53.00 TO STA. 130+77.00**  
**STA. 206+82.28 TO STA. 368+41.21**

**STA. 206+82.28 TO 368+41.21**

CURRENT YEAR = 1998 AADT = 6835  
ESTIMATED OPENING YEAR = 2000 AADT = 8600  
ESTIMATED DESIGN YEAR = 2010 AADT = 15100  
K = 10% D = 65% T = 7% (24 HOUR)  
DESIGN HOUR T = 3%  
DESIGN SPEED = 55 MPH

**MILLING**

MILL EXISTING ASPHALT PAVEMENT (2" AVG. DEPTH)

**RESURFACING**

TYPE SP STRUCTURAL COURSE (TRAFFIC B) (2")  
AND FRICTION COURSE FC-9.5 (TRAFFIC B) (1") (RUBBER)

**SHOULDER PAVEMENT RESURFACING**

FRICTION COURSE FC-9.5 (TRAFFIC B) (1") (RUBBER)

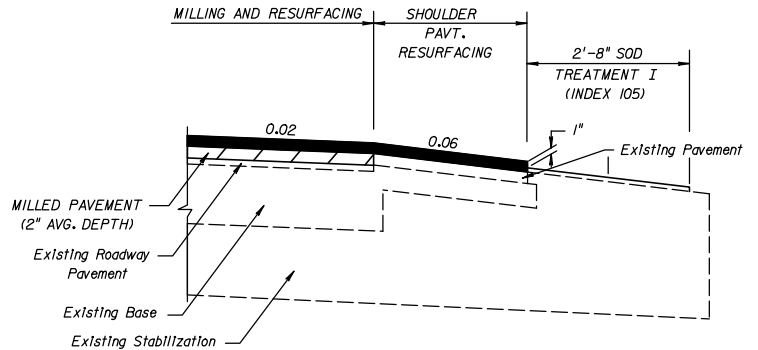

**SHOULDER PAVEMENT DETAIL**

TRAFFIC DATA IS REQUIRED TO BE NOTED FOR CURRENT YEAR, OPENING YEAR AND DESIGN YEAR.

**EXHIBIT TYP-7**  
Date: 1/1/08

| REVISIONS |             |      |             | STATE OF FLORIDA<br>DEPARTMENT OF TRANSPORTATION |        |                      | TYPICAL SECTION | SHEET NO. |
|-----------|-------------|------|-------------|--|--------|----------------------|-----------------|-----------|
| DATE      | DESCRIPTION | DATE | DESCRIPTION | ROAD NO.   | COUNTY | FINANCIAL PROJECT ID |                 |           |
|           |             |      |             | 10   | LEON   | 123456-1-52-01       |                 |           |

#USERS #DATES #TIMES #FILES

NOTICE: THE OFFICIAL RECORD OF THIS SHEET IS THE ELECTRONIC FILE SIGNED AND SEALED UNDER RULE 6805-23.003, F.A.C.

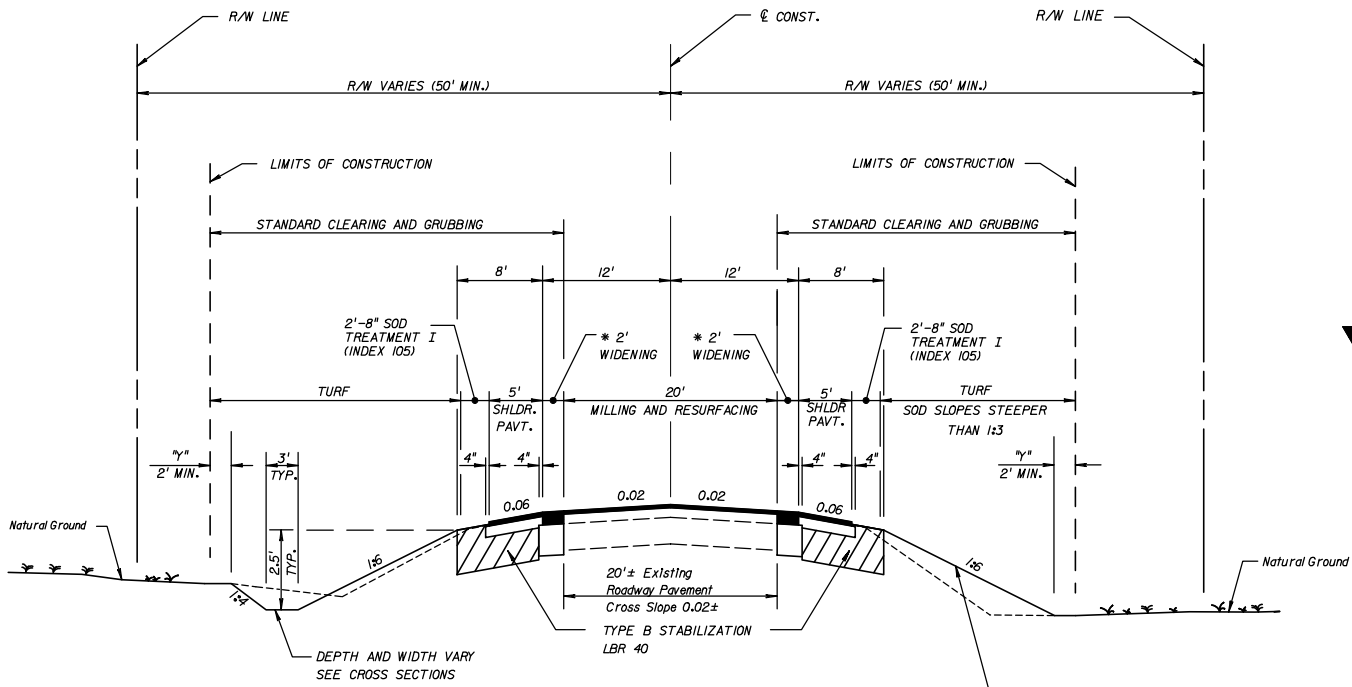

EXISTING  
2-LANE (2-WAY)  
ARTERIAL/COLLECTOR  
WIDENING  
MILLING AND RESURFACING  
UNDIVIDED  
RURAL  
CONST. 5' SHOULDER  
PAVEMENT OR BIKE LANE  
WITH PROJECTED 20 YR.  
AADT OF 1500 OR GREATER  
DESIGN SPEED GREATER  
THAN 50 MPH

DESIGNATED BIKE LANES SHALL BE LABELED  
ON TYPICAL. UNDESIGNATED BIKE LANES  
SHOULD NOT BE LABELED ON TYPICAL.

7" THE AREA DISTURBED BY CONSTRUCTION VARIES.

**TYPICAL SECTION**  
**SR 000**  
**STA. 20+25.00 TO STA. 48+16.56**  
**STA. 57+82.78 TO STA. 93+41.21**

1:6 FOR FILLS TO 5'  
1:6 TO EDGE OF CLEAR ZONE & 1:4 FOR FILLS 5' TO 10'  
1:6 TO EDGE OF CLEAR ZONE & 1:3 FOR FILLS 10' TO 20'  
1:2 (WITH GUARDRAIL) FILLS OVER 20'

NOTE:  
HEIGHT OF FILL IS THE VERTICAL DISTANCE  
FROM THE EDGE OF THE OUTSIDE TRAVEL LANE  
TO TOE OF FRONT SLOPE.

FOR STANDARD TYPICAL SECTION NOTES  
REFER TO EXHIBIT 6-1, THIS CHAPTER.

\* SEE SHEET 2 OF 2 FOR WIDENING  
AND SHOULDER PAVEMENT DETAIL

**EXHIBIT TYP-8**  
Date: 1/1/08  
SHEET 1 OF 2

**TRAFFIC DATA**  
**STA. 20+25.00 TO STA. 48+16.56**  
CURRENT YEAR = 1998 AADT = 8700  
ESTIMATED OPENING YEAR = 2000 AADT = 9200  
ESTIMATED DESIGN YEAR = 2020 AADT = 23600  
K = 10% D = 56% T = 5% (24 HOUR)  
DESIGN HOUR T = 3%  
DESIGN SPEED = 55 MPH

**STA. 57+82.78 TO STA. 93+41.21**  
CURRENT YEAR = 1998 AADT = 6835  
ESTIMATED OPENING YEAR = 2000 AADT = 8600  
ESTIMATED DESIGN YEAR = 2020 AADT = 17200  
K = 10% D = 65% T = 7% (24 HOUR)  
DESIGN HOUR T = 3%  
DESIGN SPEED = 55 MPH

TRAFFIC DATA IS REQUIRED TO BE NOTED FOR  
CURRENT YEAR, OPENING YEAR AND DESIGN YEAR.

- MILLING**  
MILL EXISTING ASPHALT PAVEMENT (2" AVG. DEPTH)
- RESURFACING**  
TYPE SP STRUCTURAL COURSE (TRAFFIC C)(1 1/2")  
AND FRICTION COURSE FC-12.5 (TRAFFIC C)(1 1/2")(RUBBER)
- WIDENING**  
OPTIONAL BASE GROUP II WITH  
TYPE SP STRUCTURAL COURSE (TRAFFIC C)(3")  
AND FRICTION COURSE FC-12.5 (TRAFFIC C)(1 1/2")(RUBBER)

| REVISIONS |             |      |             |
|-----------|-------------|------|-------------|
| DATE      | DESCRIPTION | DATE | DESCRIPTION |
|           |             |      |             |

|  |        |                      |
|--|--------|----------------------|
| <b>STATE OF FLORIDA</b><br><b>DEPARTMENT OF TRANSPORTATION</b> |        |                      |
| ROAD NO.   | COUNTY | FINANCIAL PROJECT ID |
| 10   | LEON   | 123456-1-52-01       |

**TYPICAL SECTION**

SHEET NO.

NOTICE: THE OFFICIAL RECORD OF THIS SHEET IS THE ELECTRONIC FILE SIGNED AND SEALED UNDER RULE 68G05-23.003, F.A.C.

DESIGNATED BIKE LANES SHALL BE LABELED ON TYPICAL. UNDESIGNATED BIKE LANES SHOULD NOT BE LABELED ON TYPICAL.

THE NEED FOR STABILIZATION IN THE SHOULDER AREA ON RRR PROJECTS IS SITE SPECIFIC AND NOT ALWAYS REQUIRED. THE USE OF STABILIZING IN NARROW TRENCH WIDENING STRIPS IS NOT RECOMMENDED GENERALLY. SEE THE FLEXIBLE PAVEMENT DESIGN MANUAL FOR FURTHER CRITERIA.

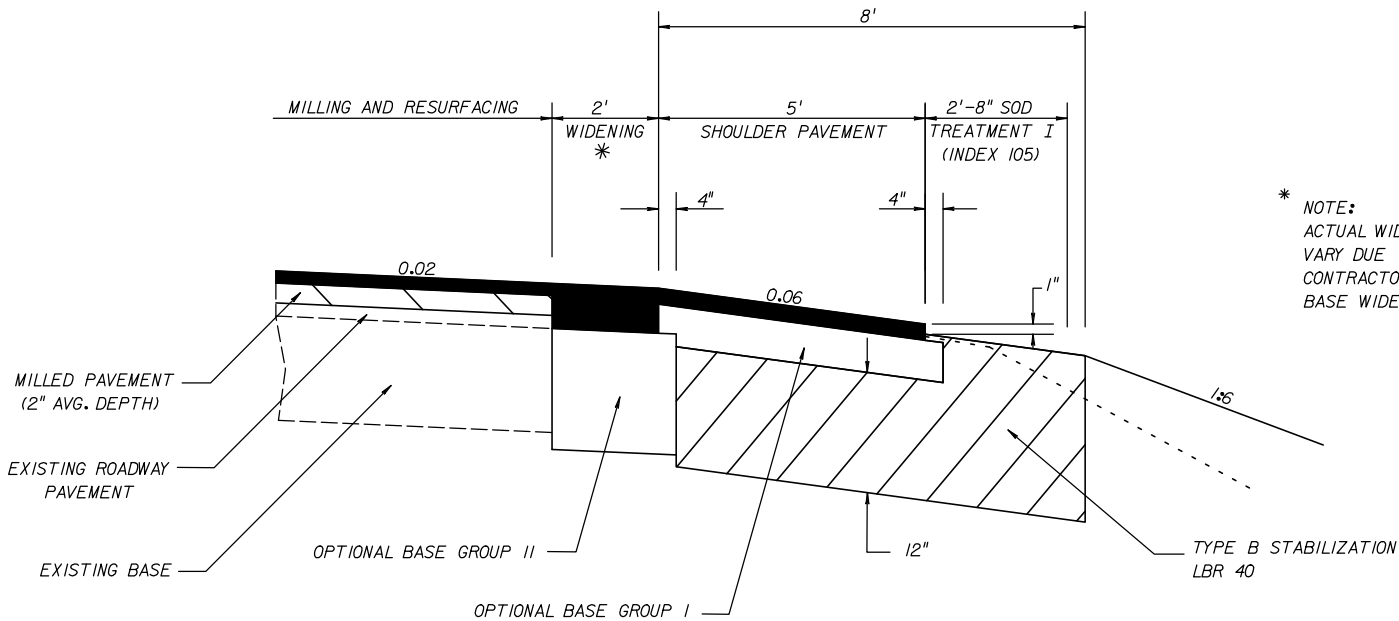

\* NOTE:  
ACTUAL WIDTH OF BASE WIDENING MAY VARY DUE TO ACTUAL PAVEMENT WIDTH. CONTRACTOR MAY ELECT TO PLACE UNIFORM BASE WIDENING AT NO ADDITIONAL COST.

WIDENING &  
SHOULDER PAVEMENT DETAIL

WIDENING

OPTIONAL BASE GROUP II WITH  
TYPE SP STRUCTURAL COURSE (TRAFFIC C) (3")  
FRICTION COURSE FC-12.5 (TRAFFIC C) (1/2") (RUBBER)

SHOULDER PAVEMENT

OPTIONAL BASE GROUP I WITH  
FRICTION COURSE FC-12.5 (TRAFFIC C) (1/2") (RUBBER)

FOR STANDARD TYPICAL SECTION NOTES  
REFER TO EXHIBIT 6-1, THIS CHAPTER

EXHIBIT TYP-8A  
Date: 1/1/08

| REVISIONS |             |      |             | STATE OF FLORIDA<br>DEPARTMENT OF TRANSPORTATION |        |                      | TYPICAL SECTION | SHEET NO. |
|-----------|-------------|------|-------------|--|--------|----------------------|-----------------|-----------|
| DATE      | DESCRIPTION | DATE | DESCRIPTION | ROAD NO.   | COUNTY | FINANCIAL PROJECT ID |                 |           |
|           |             |      |             | 10   | LEON   | 123456-1-52-01       |                 |           |

#USERS #DATES #TIMES #FILES

NOTICE: THE OFFICIAL RECORD OF THIS SHEET IS THE ELECTRONIC FILE SIGNED AND SEALED UNDER RULE 6805-23.003, F.A.C.

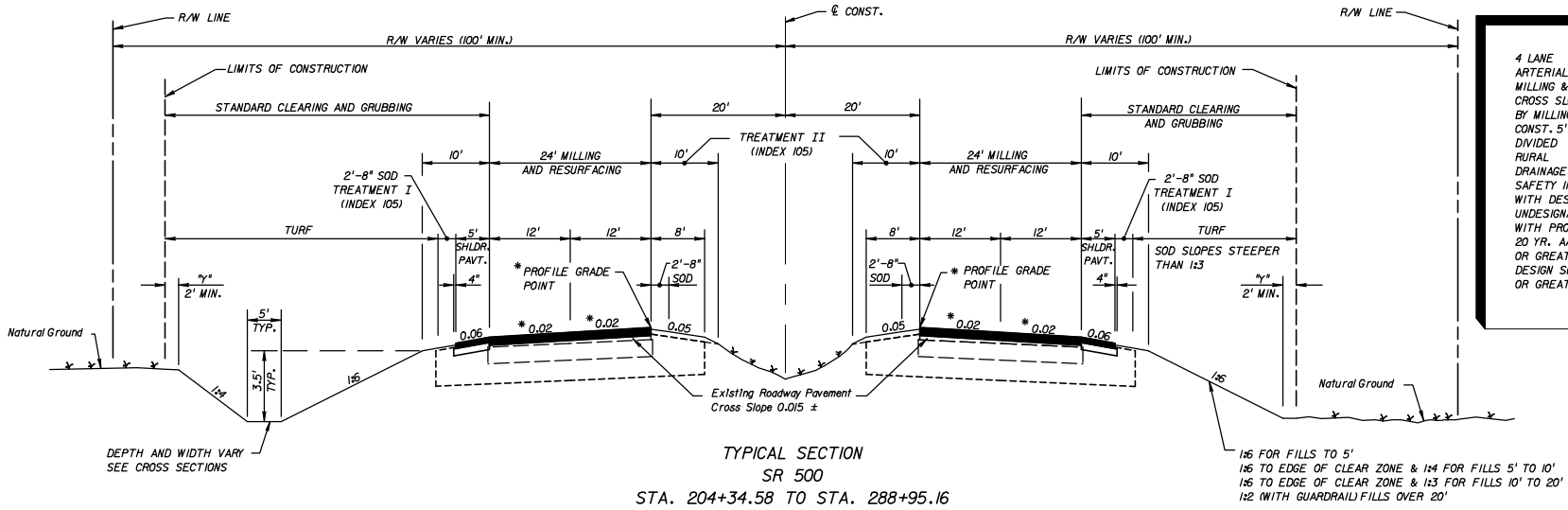

4 LANE  
ARTERIAL/COLLECTOR  
MILLING & RESURFACING  
CROSS SLOPE CORRECTION  
BY MILLING OR OVERBUILD  
CONST. 5' SHLDR. PAV'T  
DIVIDED  
RURAL  
DRAINAGE IMPROVEMENTS  
SAFETY IMPROVEMENTS  
WITH DESIGNATED OR  
UNDESIGNATED BIKE LANE  
WITH PROJECTED  
20 YR. AADT OF 1500  
OR GREATER  
DESIGN SPEED 45 MPH  
OR GREATER

DESIGNATED BIKE LANES SHALL BE LABELED ON TYPICAL. UNDESIGNATED BIKE LANES SHOULD NOT BE LABELED ON TYPICAL.

**TRAFFIC DATA**  
CURRENT YEAR = 1998 AADT = 18100  
ESTIMATED OPENING YEAR = 2000 AADT = 21000  
ESTIMATED DESIGN YEAR = 2012 AADT = 38900  
K = 112 D = 58X T = 22X (24 HOUR)  
DESIGN HOUR T = 11X  
DESIGN SPEED = 60 MPH  
POSTED SPEED = 55 MPH

TRAFFIC DATA IS REQUIRED TO BE NOTED FOR CURRENT YEAR, OPENING YEAR, AND DESIGN YEAR. POSTED SPEED (MPH) IS OPTIONAL.

\* WHEN CROSS SLOPE CORRECTION IS NECESSARY SPECIAL MILLING, OVERBUILD AND LAYERING DETAILS MUST BE PROVIDED TO SUPPLEMENT TYPICAL SECTION. THE NEED FOR AND LOCATION OF PROFILE GRADE POINTS WILL DEPEND ON SITE SPECIFIC CONDITIONS.

**MILLING**  
MILL EXISTING ASPHALT PAVEMENT (1/2" AVG. DEPTH)

**RESURFACING**  
TYPE SP STRUCTURAL COURSE (TRAFFIC D) (1/2")  
TYPE SP STRUCTURAL COURSE (TRAFFIC D) (1/2") (PG 76-22)  
AND FRICTION COURSE FC-5 (3/4") (PG 76-22)

**SHOULDER PAVEMENT**  
OPTIONAL BASE GROUP I WITH  
TYPE SP STRUCTURAL COURSE (TRAFFIC D) (1/2") (PG 76-22)  
AND FRICTION COURSE FC-5 (3/4") (PG 76-22)

STA. 316+53.67 TO STA. 527+82.00  
**MILLING**  
MILL EXISTING ASPHALT PAVEMENT (1/2" AVG. DEPTH)

**OVERBUILD**  
TYPE SP OVERBUILD (TRAFFIC D) THICKNESS VARIES (1" TO 1 1/2")

**RESURFACING**  
TYPE SP STRUCTURAL COURSE (TRAFFIC D) (1/2")  
TYPE SP STRUCTURAL COURSE (TRAFFIC D) (1/2") (PG 76-22)  
AND FRICTION COURSE FC-5 (3/4") (PG 76-22)

**SHOULDER PAVEMENT**  
OPTIONAL BASE GROUP I WITH  
TYPE SP STRUCTURAL COURSE (TRAFFIC D) (1/2") (PG 76-22)  
AND FRICTION COURSE FC-5 (3/4") (PG 76-22)

**NOTE:**  
HEIGHT OF FILL IS THE VERTICAL DISTANCE FROM THE EDGE OF THE OUTSIDE TRAVEL LANE TO TOE OF FRONT SLOPE.

"Y" THE AREA DISTURBED BY CONSTRUCTION VARIES.

FOR STANDARD TYPICAL SECTION NOTES REFER TO EXHIBIT 6-1, THIS CHAPTER.

FOR MILLING AND RESURFACING DETAILS SEE TYPICAL SECTION DETAILS SHEET 2 AND 3

**EXHIBIT TYP-9**  
Date: 1/1/08

SHEET 1 OF 3

| REVISIONS |             |      |             | STATE OF FLORIDA<br>DEPARTMENT OF TRANSPORTATION |        |                      | TYPICAL SECTION | SHEET NO. |
|-----------|-------------|------|-------------|--|--------|----------------------|-----------------|-----------|
| DATE      | DESCRIPTION | DATE | DESCRIPTION | ROAD NO.   | COUNTY | FINANCIAL PROJECT ID |                 |           |
|           |             |      |             | 10   | LEON   | 123456-1-52-01       |                 |           |

#USERS #DATES #TIMES #FILES

NOTICE: THE OFFICIAL RECORD OF THIS SHEET IS THE ELECTRONIC FILE SIGNED AND SEALED UNDER RULE 6805-23.003, F.A.C.

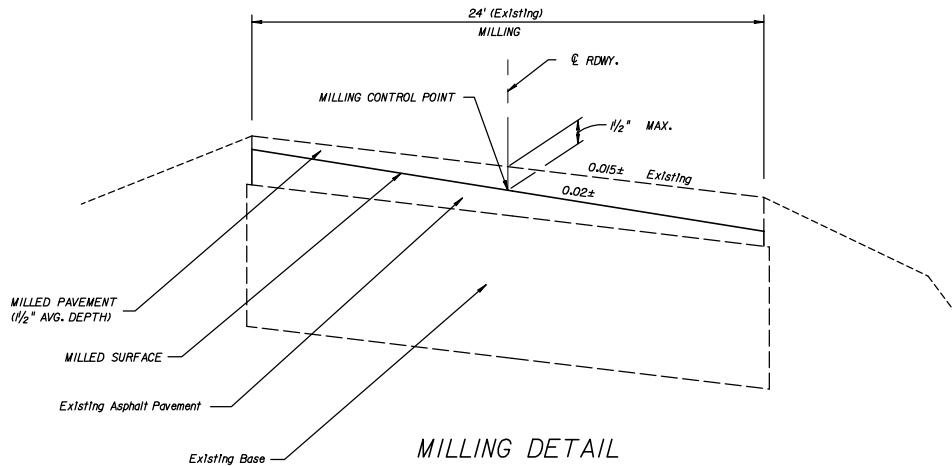

WHEN CROSS SLOPE CORRECTION IS NECESSARY SPECIAL MILLING AND LAYERING DETAILS MUST BE PROVIDED TO SUPPLEMENT TYPICAL SECTION. THE NEED FOR AND LOCATION OF PROFILE GRADE POINTS WILL DEPEND ON SITE SPECIFIC CONDITIONS.

EXAMPLE OF CROSS SLOPE CORRECTION BY MILLING.

FOR STANDARD TYPICAL SECTION NOTES REFER TO EXHIBIT 6-1, THIS CHAPTER.

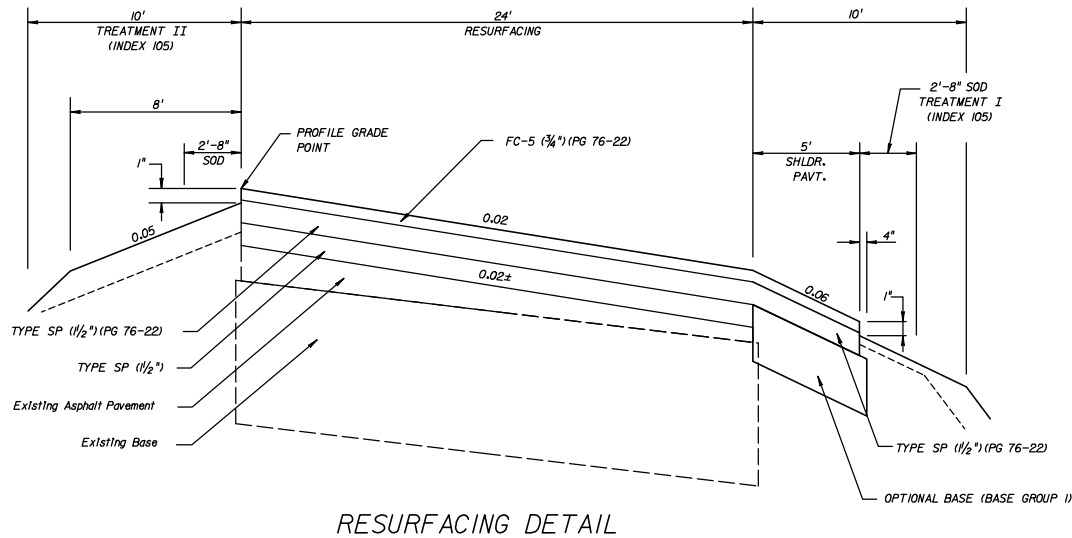

STA. 204+34.58 TO STA. 288+95.16

EXHIBIT TYP-9A  
Date: 1/1/08

SHEET 2 OF 3

| REVISIONS |             |      |             | STATE OF FLORIDA<br>DEPARTMENT OF TRANSPORTATION |        |                      | TYPICAL SECTION DETAILS | SHEET NO. |
|-----------|-------------|------|-------------|--|--------|----------------------|-------------------------|-----------|
| DATE      | DESCRIPTION | DATE | DESCRIPTION | ROAD NO.   | COUNTY | FINANCIAL PROJECT ID |                         |           |
|           |             |      |             | 10   | LEON   | 123456-1-52-01       |                         |           |

#USERS #DATES #TIMES #FILES

NOTICE: THE OFFICIAL RECORD OF THIS SHEET IS THE ELECTRONIC FILE SIGNED AND SEALED UNDER RULE 6805-23.003, F.A.C.

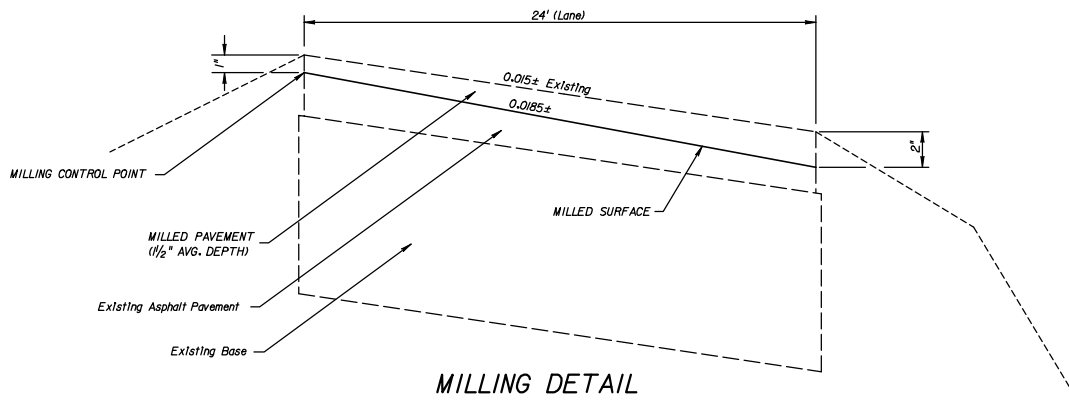

WHEN CROSS SLOPE CORRECTION IS NECESSARY SPECIAL MILLING, OVERBUILD AND LAYERING DETAILS MUST BE PROVIDED TO SUPPLEMENT TYPICAL SECTION. THE NEED FOR AND LOCATION OF PROFILE GRADES POINTS WILL DEPEND ON SITE SPECIFIC CONDITIONS.

EXAMPLE OF CROSS SLOPE CORRECTION BY MILLING AND OVERBUILD.

FOR STANDARD TYPICAL SECTION NOTES REFER TO EXHIBIT 6-1, THIS CHAPTER.

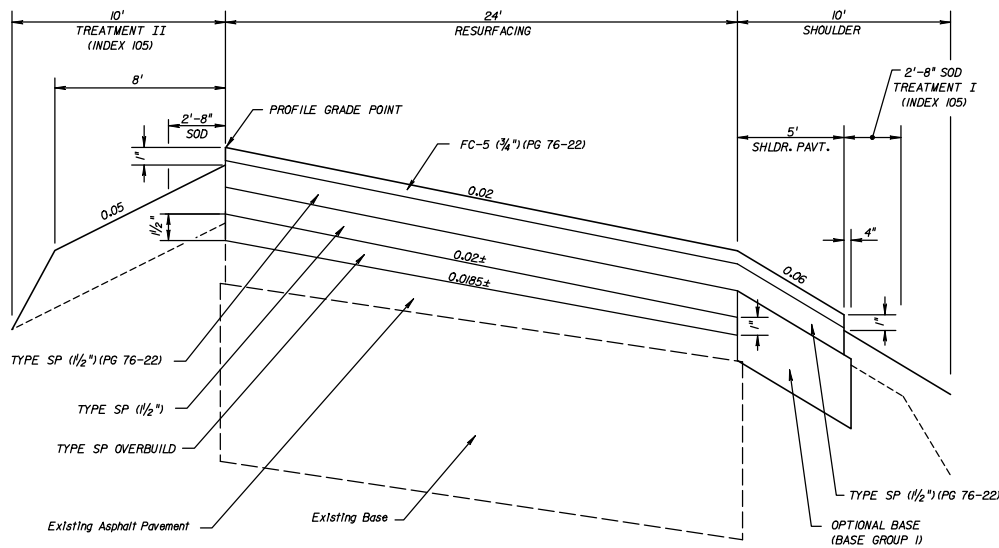

SUGGESTED CONSTRUCTION SEQUENCES SHOWN. OTHER SEQUENCES THAT MEET SPECIFICATIONS, THICKNESS AND CROSS SLOPE REQUIREMENTS MAY BE CONSIDERED BY THE ENGINEER.

STA. 316+53.67 TO STA. 527+82.00

EXHIBIT TYP-9B  
Date: 1/1/08

SHEET 3 OF 3

| REVISIONS |             | STATE OF FLORIDA<br>DEPARTMENT OF TRANSPORTATION |             |                        | SHEET NO.               |
|-----------|-------------|--|-------------|------------------------|-------------------------|
| DATE      | DESCRIPTION | DATE   | DESCRIPTION | FINANCIAL PROJECT ID   |                         |
|           |             |  |             | 10 LEON 123456-1-52-01 | TYPICAL SECTION DETAILS |
|           |             |  |             |                        |                         |

#USERS #DATES #TIMES #FILES

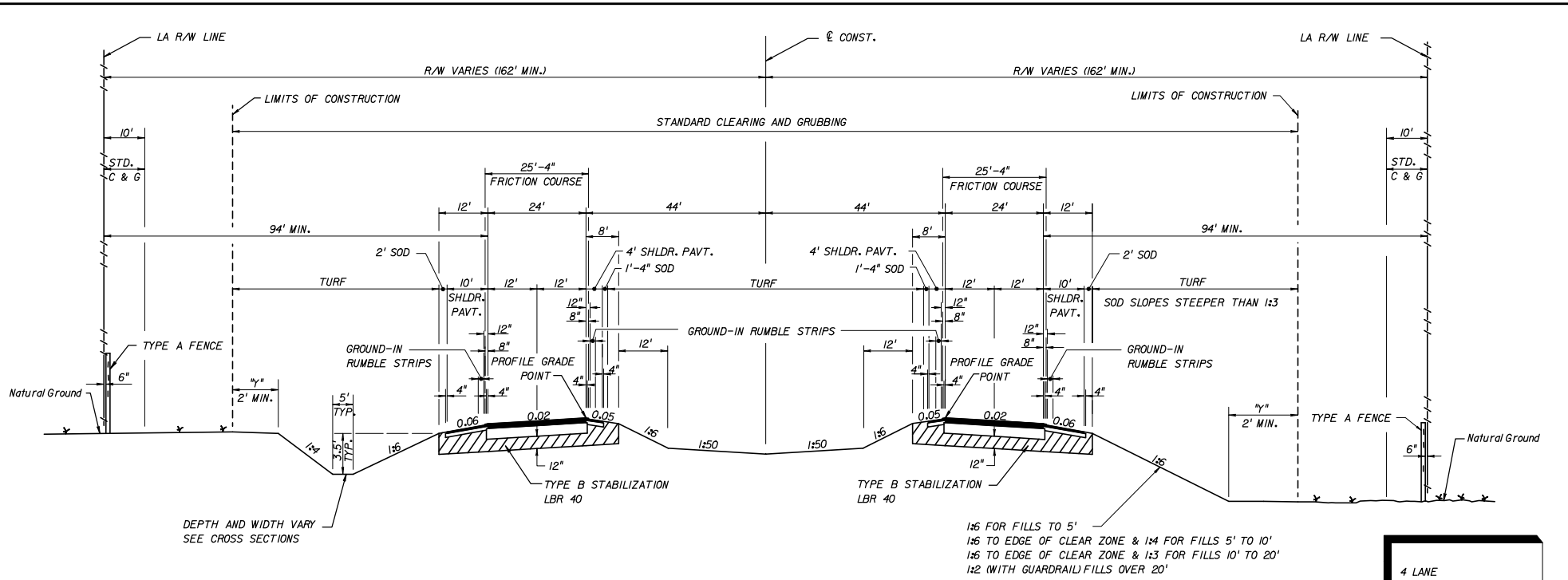

**TRAFFIC DATA**

CURRENT YEAR = 1998 AADT = 22300  
 ESTIMATED OPENING YEAR = 2000 AADT = 23300  
 ESTIMATED DESIGN YEAR = 2020 AADT = 51500  
 K = 9 % D = 56 % T = 10 % (24 HOUR)  
 DESIGN HOUR T = 5 %  
 DESIGN SPEED = 70 MPH

TRAFFIC DATA IS REQUIRED TO BE NOTED FOR CURRENT YEAR, OPENING YEAR, AND DESIGN YEAR. POSTED SPEED (MPH) IS OPTIONAL.

FOR STANDARD TYPICAL SECTION NOTES REFER TO EXHIBIT 6-1, THIS CHAPTER

**TYPICAL SECTION  
 SR 8  
 STA. 567+25.67 TO STA. 1056+84.35**

**NEW CONSTRUCTION**

OPTIONAL BASE GROUP 9 WITH  
 TYPE SP STRUCTURAL COURSE (TRAFFIC D) (2 1/2")  
 TYPE SP STRUCTURAL COURSE (TRAFFIC D) (1 1/2") (PG 76-22) AND  
 FRICTION COURSE FC-5 (3/4") (PG 76-22)

**MEDIAN SHOULDER PAVEMENT**

OPTIONAL BASE GROUP 1 WITH  
 TYPE SP STRUCTURAL COURSE (TRAFFIC D) (1 1/2")  
 TYPE SP STRUCTURAL COURSE (TRAFFIC D) (1 1/2") (PG 76-22) AND  
 FRICTION COURSE FC-5 (3/4") (PG 76-22)

**OUTSIDE SHOULDER PAVEMENT**

OPTIONAL BASE GROUP 1 WITH  
 TYPE SP STRUCTURAL COURSE (TRAFFIC B) (1 1/2") AND  
 FRICTION COURSE FC-5 (3/4") (PG 76-22)

NOTE:  
 HEIGHT OF FILL IS THE VERTICAL DISTANCE FROM THE EDGE OF THE OUTSIDE TRAVEL LANE TO TOE OF FRONT SLOPE.

1:6 FOR FILLS TO 5'  
 1:6 TO EDGE OF CLEAR ZONE & 1:4 FOR FILLS 5' TO 10'  
 1:6 TO EDGE OF CLEAR ZONE & 1:3 FOR FILLS 10' TO 20'  
 1:2 (WITH GUARDRAIL) FILLS OVER 20'

4 LANE INTERSTATE SYSTEM  
 NEW CONSTRUCTION  
 DIVIDED RURAL  
 WITH PROJECTED 20 YR. AADT OF 1500 OR GREATER  
 DESIGN SPEED TO MPH

"y" THE AREA DISTURBED BY CONSTRUCTION VARIES.

EXHIBIT TYP-10  
 Date: 1/1/08

| REVISIONS |             |      |             | STATE OF FLORIDA<br>DEPARTMENT OF TRANSPORTATION |        |                      | TYPICAL SECTION | SHEET NO. |
|-----------|-------------|------|-------------|--|--------|----------------------|-----------------|-----------|
| DATE      | DESCRIPTION | DATE | DESCRIPTION | ROAD NO.   | COUNTY | FINANCIAL PROJECT ID |                 |           |
|           |             |      |             | 10   | LEON   | 123456-1-52-01       |                 |           |

#USERS #DATES #TIMES #FILES

NOTICE: THE OFFICIAL RECORD OF THIS SHEET IS THE ELECTRONIC FILE SIGNED AND SEALED UNDER RULE 68G5-23.003, F.A.C.

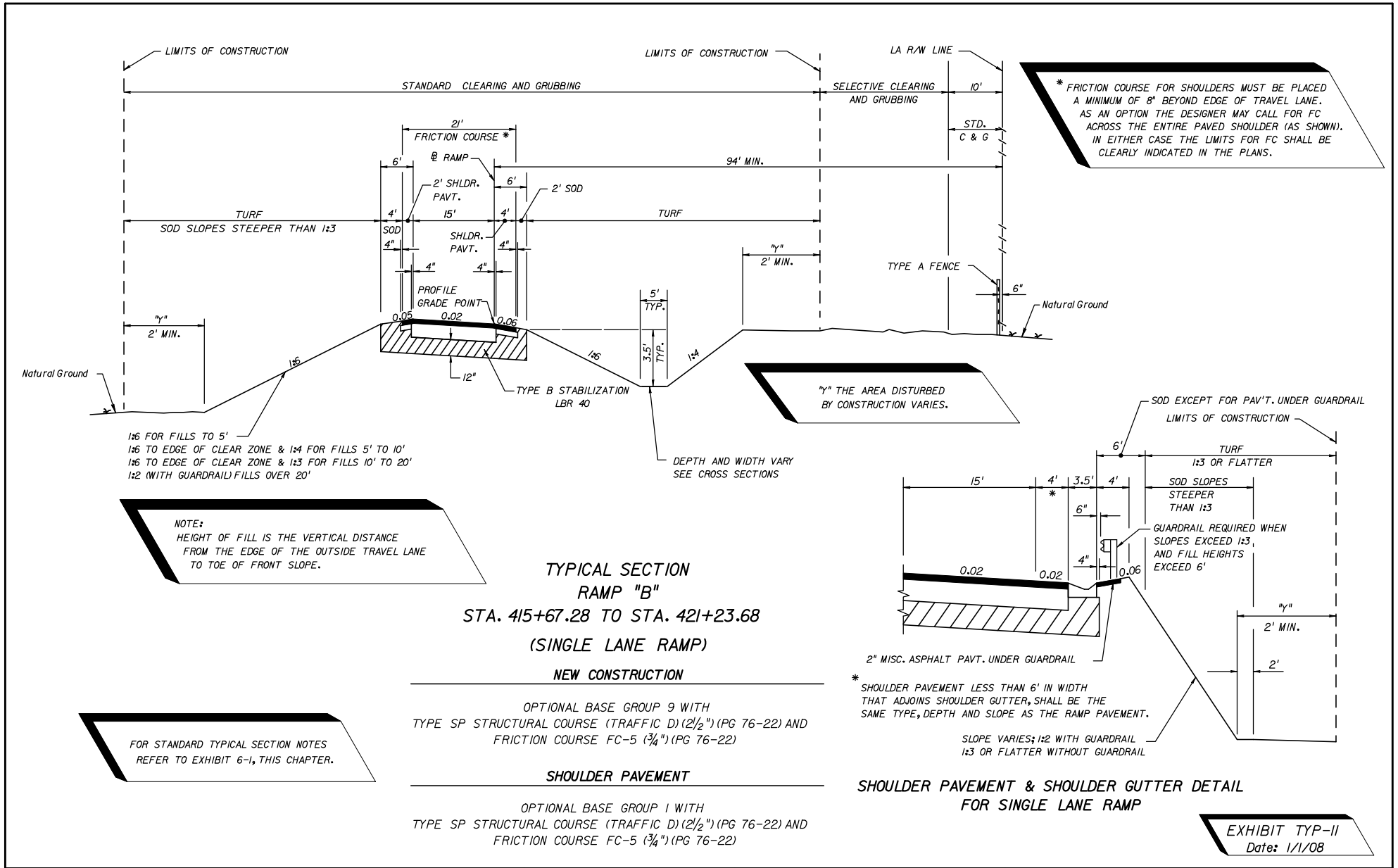

| REVISIONS |             | STATE OF FLORIDA<br>DEPARTMENT OF TRANSPORTATION |             |                        | SHEET NO.            |
|-----------|-------------|--|-------------|------------------------|----------------------|
| DATE      | DESCRIPTION | DATE   | DESCRIPTION | FINANCIAL PROJECT ID   |                      |
|           |             |  |             | 10 LEON 123456-1-52-01 | RAMP TYPICAL SECTION |
|           |             |  |             |                        |                      |

NOTICE: THE OFFICIAL RECORD OF THIS SHEET IS THE ELECTRONIC FILE SIGNED AND SEALED UNDER RULE 6805-23.003, F.A.C.

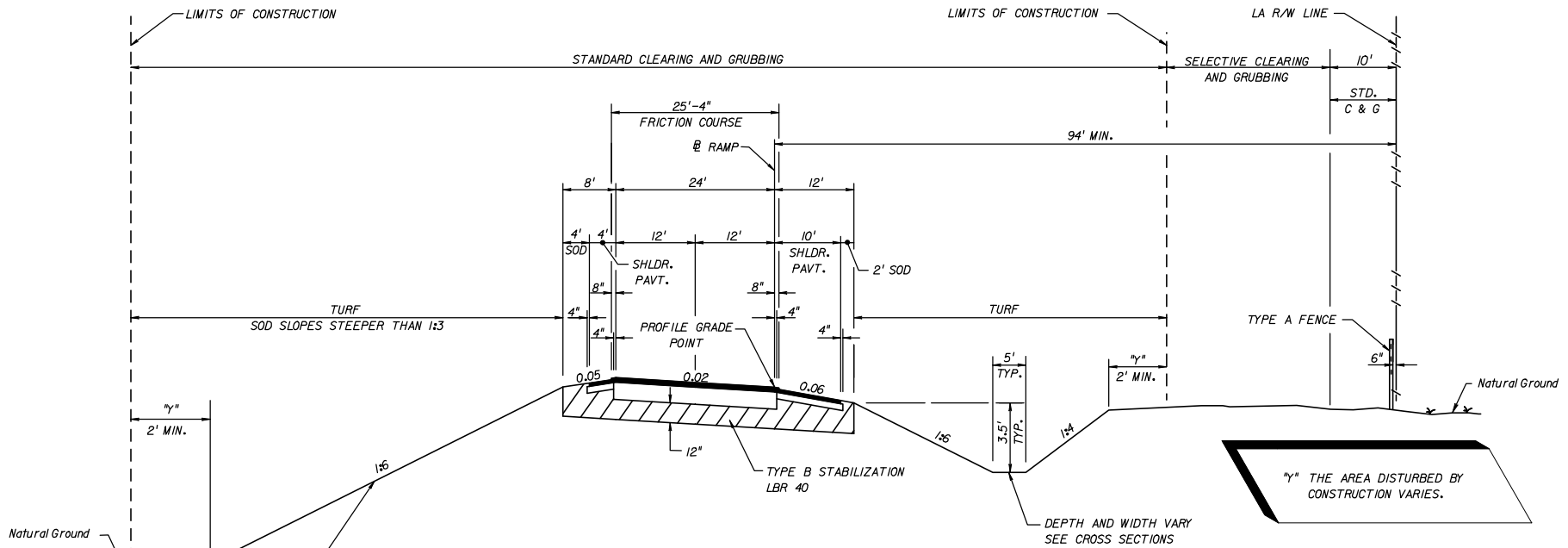

**TYPICAL SECTION  
RAMP "C"  
STA. 623+28.64 TO STA. 629+13.78  
(TWO LANE RAMP)**

**NEW CONSTRUCTION**

OPTIONAL BASE GROUP 9 WITH  
TYPE SP STRUCTURAL COURSE (TRAFFIC D) (2") (PG 76-22) AND  
FRICTION COURSE FC-5 (3/4") (PG 76-22)

**LEFT SHOULDER PAVEMENT**

OPTIONAL BASE GROUP 1 WITH  
TYPE SP STRUCTURAL COURSE (TRAFFIC D) (2") (PG 76-22) AND  
FRICTION COURSE FC-5 (3/4") (PG 76-22)

**RIGHT SHOULDER PAVEMENT**

OPTIONAL BASE GROUP 1 WITH  
TYPE SP STRUCTURAL COURSE (TRAFFIC B) (2") AND  
FRICTION COURSE FC-5 (3/4") (PG 76-22)

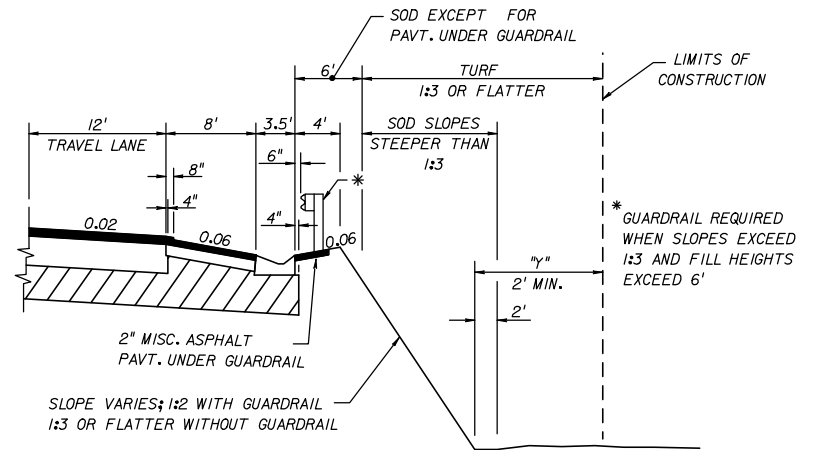

**SHOULDER PAVEMENT & SHOULDER GUTTER DETAIL  
MAINLINE AND MULTILANE RAMPS**

**EXHIBIT TYP-12  
Date: 1/1/08**

1:6 FOR FILLS TO 5'  
1:6 TO EDGE OF CLEAR ZONE & 1:4 FOR FILLS 5' TO 10'  
1:6 TO EDGE OF CLEAR ZONE & 1:3 FOR FILLS 10' TO 20'  
1:2 (WITH GUARDRAIL) FILLS OVER 20'

**NOTE:**  
HEIGHT OF FILL IS THE VERTICAL DISTANCE  
FROM THE EDGE OF THE OUTSIDE TRAVEL LANE  
TO TOE OF FRONT SLOPE.

FOR STANDARD TYPICAL SECTION NOTES  
REFER TO EXHIBIT 6-1, THIS CHAPTER

| REVISIONS |             |      |             | STATE OF FLORIDA<br>DEPARTMENT OF TRANSPORTATION |        |                      | RAMP TYPICAL SECTION | SHEET<br>NO. |
|-----------|-------------|------|-------------|--|--------|----------------------|----------------------|--------------|
| DATE      | DESCRIPTION | DATE | DESCRIPTION | ROAD NO.   | COUNTY | FINANCIAL PROJECT ID |                      |              |
|           |             |      |             | 10   | LEON   | 123456-1-52-01       |                      |              |

#USERS #DATES #TIMES #FILES

DESIGNATED BIKE LANES SHALL BE LABELED ON TYPICAL. UNDESIGNATED BIKE LANES SHOULD NOT BE LABELED ON TYPICAL.

IF LANDSCAPING IS DESIRED, TREES SHALL BE TYPES THAT WILL NOT HAVE AN EXPECTED GROWTH GREATER THAN 4" IN DIAMETER MEASURED 6" ABOVE THE GROUND.

TURF SLOPES 1:3 OR FLATTER  
\* SOD SLOPES STEEPER THAN 1:3

4-LANE  
ARTERIAL  
NEW CONSTRUCTION  
DIVIDED  
SUBURBAN  
WITH DESIGNATED OR  
UNDESIGNATED BIKE LANE  
DESIGN SPEED 55 MPH

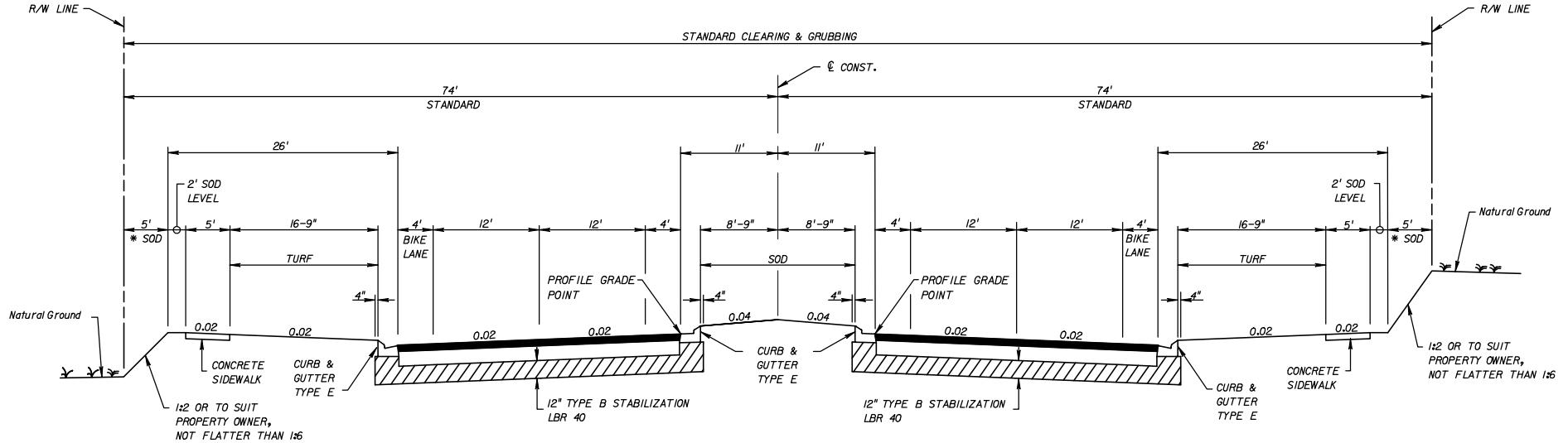

**TRAFFIC DATA**

CURRENT YEAR = 1999 AADT = 22800  
 ESTIMATED OPENING YEAR = 2002 AADT = 25800  
 ESTIMATED DESIGN YEAR = 2022 AADT = 30600  
 K = 6% D = 55% T = 2% (24 HOUR)  
 DESIGN HOUR T = 1%  
 DESIGN SPEED = 55 MPH

**SUBURBAN TYPICAL SECTION  
 SR 00 (SARA AVE.)  
 STA. 50+40.00 TO STA. 125+50.00**

**NEW CONSTRUCTION**

OPTIONAL BASE GROUP 9 WITH  
 TYPE SP STRUCTURAL COURSE (TRAFFIC C) (3 1/2")  
 AND FRICTION COURSE FC-5 (3/4") (RUBBER)

TRAFFIC DATA IS REQUIRED TO BE NOTED FOR CURRENT YEAR, OPENING YEAR AND DESIGN YEAR.  
 POSTED SPEED (MPH) IS OPTIONAL.

FOR STANDARD TYPICAL SECTION NOTES REFER TO EXHIBIT 6-1, THIS CHAPTER.

EXHIBIT TYP-13  
 Date: 1/1/08

| REVISIONS |             | STATE OF FLORIDA<br>DEPARTMENT OF TRANSPORTATION |             |                        | SHEET NO.                |
|-----------|-------------|--|-------------|------------------------|--------------------------|
| DATE      | DESCRIPTION | DATE   | DESCRIPTION | FINANCIAL PROJECT ID   |                          |
|           |             |  |             | 10 LEON 123456-1-52-01 | SUBURBAN TYPICAL SECTION |
|           |             |  |             |                        |                          |

#USERS #DATES #TIMES #FILES

NOTICE: THE OFFICIAL RECORD OF THIS SHEET IS THE ELECTRONIC FILE SIGNED AND SEALED UNDER RULE 68G05-23.003, F.A.C.

DESIGNATED BIKE LANES SHALL BE LABELED ON TYPICAL. UNDESIGNATED BIKE LANES SHOULD NOT BE LABELED ON TYPICAL.

4-LANE  
ARTERIAL  
NEW CONSTRUCTION  
DIVIDED  
SUBURBAN  
WITH DESIGNATED OR  
UNDESIGNATED BIKE LANE  
DESIGN SPEED 55 MPH OR LESS

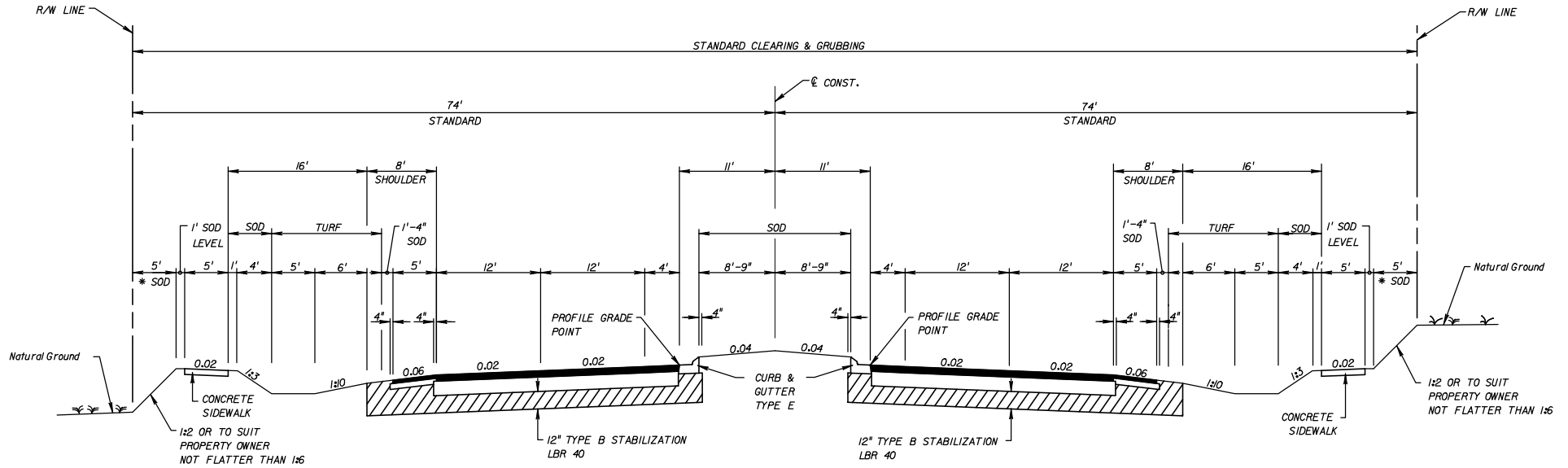

**TRAFFIC DATA**

CURRENT YEAR = 1999 AADT = 22800  
 ESTIMATED OPENING YEAR = 2002 AADT = 25800  
 ESTIMATED DESIGN YEAR = 2022 AADT = 30600  
 K = 6% D = 55% T = 2% (24 HOUR)  
 DESIGN HOUR T = 1%  
 DESIGN SPEED = 55 MPH

TRAFFIC DATA IS REQUIRED TO BE NOTED FOR CURRENT YEAR, OPENING YEAR AND DESIGN YEAR. POSTED SPEED (MPH) IS OPTIONAL.

FOR STANDARD TYPICAL SECTION NOTES REFER TO EXHIBIT 6-1, THIS CHAPTER.

**SUBURBAN TYPICAL SECTION  
 SR 00 (CODY ROAD)  
 STA. 100+40.00 TO STA. 225+50.00**

**NEW CONSTRUCTION**

OPTIONAL BASE GROUP 9 WITH  
 TYPE SP STRUCTURAL COURSE (TRAFFIC C) (3 1/2")  
 AND FRICTION COURSE FC-5 (3/4") (RUBBER)

**SHOULDER PAVEMENT**

OPTIONAL BASE GROUP 1 WITH  
 TYPE SP STRUCTURAL COURSE (TRAFFIC C) (1 1/2")  
 AND FRICTION COURSE FC-5 (3/4") (RUBBER)

TURF SLOPES 1:3 OR FLATTER  
 \* SOD SLOPES STEEPER THAN 1:3

IF LANDSCAPING IS DESIRED, TREES SHALL BE TYPES THAT WILL NOT HAVE AN EXPECTED GROWTH GREATER THAN 4" IN DIAMETER MEASURED 6" ABOVE THE GROUND.

**EXHIBIT TYP-14**  
 Date: 1/1/08

| REVISIONS |             |      |             | STATE OF FLORIDA<br>DEPARTMENT OF TRANSPORTATION |        |                      | SUBURBAN TYPICAL SECTION | SHEET NO. |
|-----------|-------------|------|-------------|--|--------|----------------------|--------------------------|-----------|
| DATE      | DESCRIPTION | DATE | DESCRIPTION | ROAD NO.   | COUNTY | FINANCIAL PROJECT ID |                          |           |
|           |             |      |             | 10   | LEON   | 123456-1-52-01       |                          |           |

#USERS #DATES #TIMES #FILES

NOTICE: THE OFFICIAL RECORD OF THIS SHEET IS THE ELECTRONIC FILE SIGNED AND SEALED UNDER RULE 6805-23.003, F.A.C.

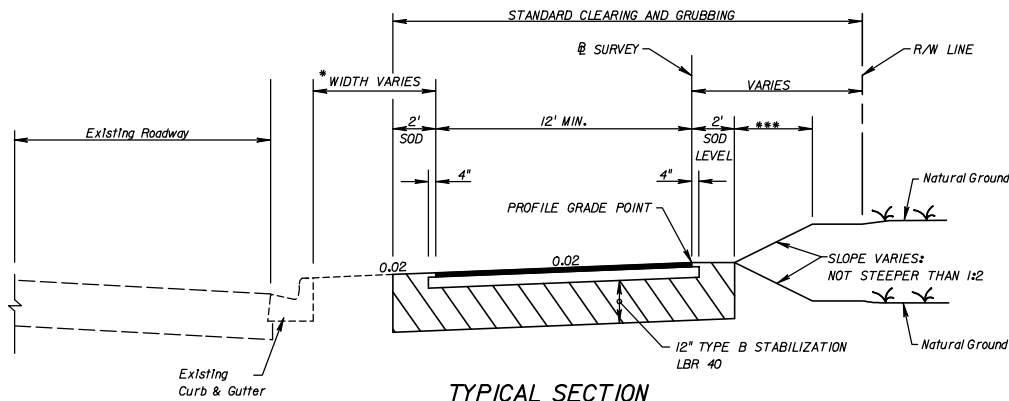

**TYPICAL SECTION  
SHARED USE PATH  
SR 00 (WILLOW WAY)  
STA. 122+00.000 TO STA. 210+65.000  
PATH**

OPTIONAL BASE GROUP 1 WITH  
TYPE SP STRUCTURAL COURSE (TRAFFIC A) (1")

\* FOR ROADWAYS WITH CURBS, A MINIMUM SEPARATION OF 4 FEET MEASURED FROM THE BACK OF CURB SHOULD BE PROVIDED.

\*\*\* TURF OR SOD

NOTE:  
THE DESIGN SPEED FOR SHARED USE PATHS IS 20 MPH.

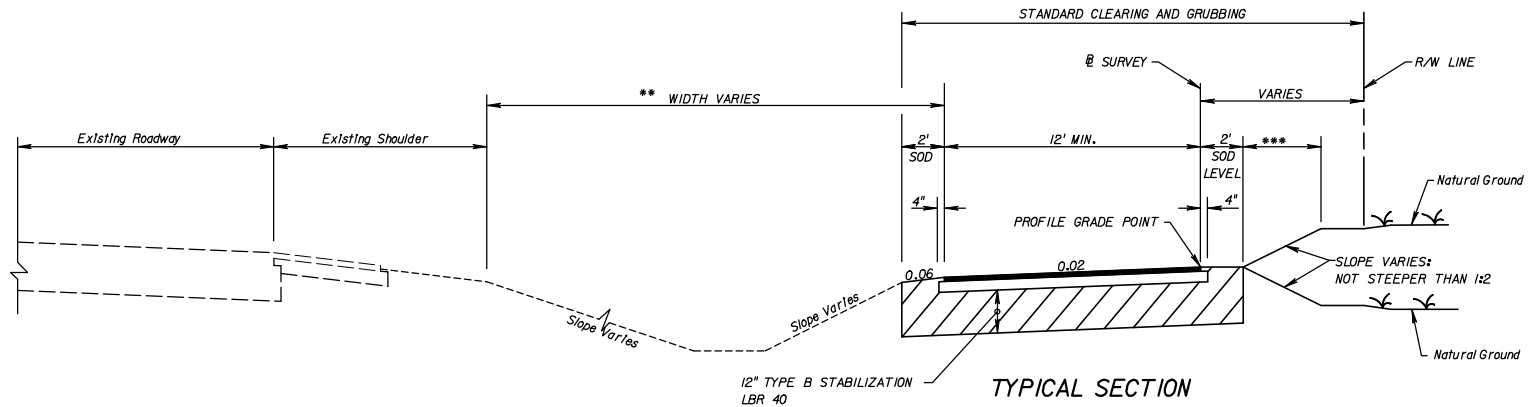

**TYPICAL SECTION  
SHARED USE PATH  
SR 00 (DEXTON HEIGHTS)  
STA. 22+00.000 TO STA. 51+65.000  
PATH**

OPTIONAL BASE GROUP 1 WITH  
TYPE SP STRUCTURAL COURSE (TRAFFIC A) (1")

\*\* FOR ROADWAYS WITH FLUSH SHOULDERS, A MINIMUM SEPARATION OF 5 FEET MEASURED FROM THE OUTSIDE EDGE OF SHOULDER TO THE INSIDE EDGE OF THE SHARED USE PATH SHOULD BE PROVIDED.

EXHIBIT TYP-15  
Date: 1/1/08

| REVISIONS |             |      |             |
|-----------|-------------|------|-------------|
| DATE      | DESCRIPTION | DATE | DESCRIPTION |
|           |             |      |             |

|  |        |                      |
|--|--------|----------------------|
| STATE OF FLORIDA<br>DEPARTMENT OF TRANSPORTATION |        |                      |
| ROAD NO.   | COUNTY | FINANCIAL PROJECT ID |
| 10   | LEON   | 123456-1-52-01       |

**SHARED USE PATH**

SHEET NO.

#USERS #DATES #TIMES #FILES

NOTICE: THE OFFICIAL RECORD OF THIS SHEET IS THE ELECTRONIC FILE SIGNED AND SEALED UNDER RULE 6805-23.003, F.A.C.

\*\*\*\* IF LIMITS OF CONSTRUCTION EXCEED RIGHT OF WAY, A PROPERTY AGREEMENT IS REQUIRED.

6-LANE ARTERIAL  
NEW CONSTRUCTION  
DIVIDED  
URBAN  
DESIGN SPEED 50 MPH

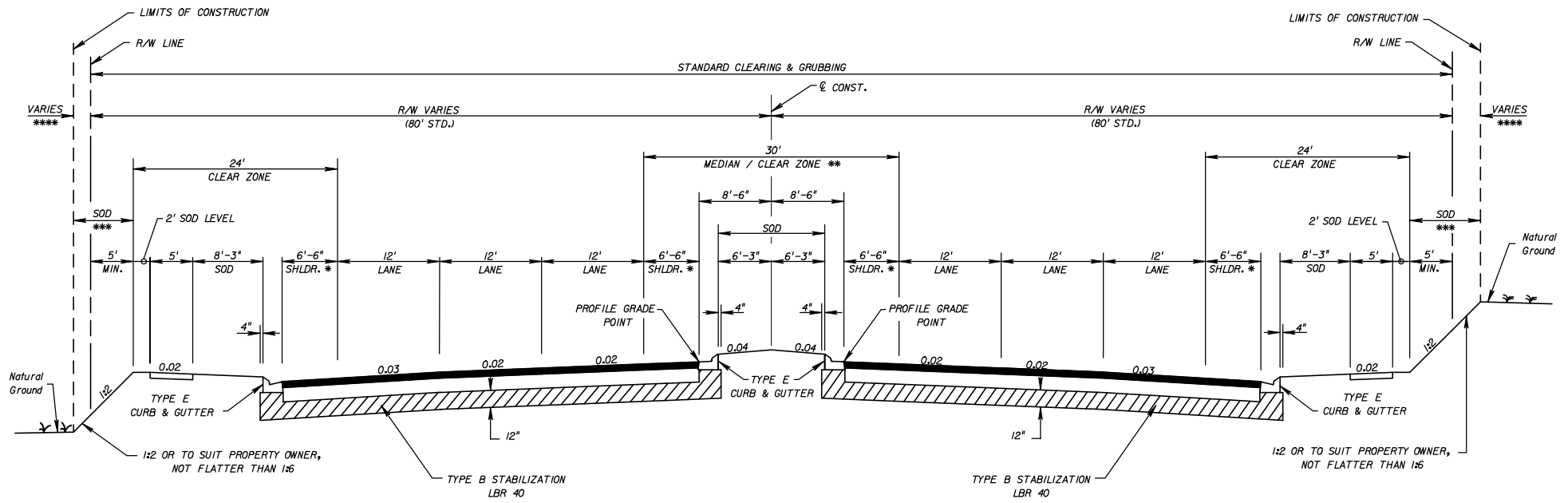

**TYPICAL SECTION**  
**SR 00 (SOUTH INDEPENDENCE STREET)**  
**STA. 401+30.00 TO STA. 788+66.00**

**TRAFFIC DATA**

CURRENT YEAR = 1998 AADT = 22800  
ESTIMATED OPENING YEAR = 2000 AADT = 25800  
ESTIMATED DESIGN YEAR = 2020 AADT = 30600  
K = 6% D = 55% T = 2% (24 HOUR)  
DESIGN HOUR T = 1%  
DESIGN SPEED = 50 MPH

TRAFFIC DATA IS REQUIRED TO BE NOTED FOR CURRENT YEAR, OPENING YEAR AND DESIGN YEAR.

FOR STANDARD TYPICAL SECTION NOTES REFER TO EXHIBIT 6-1, THIS CHAPTER.

**NEW CONSTRUCTION**

OPTIONAL BASE GROUP 9 WITH  
TYPE SP STRUCTURAL COURSE (TRAFFIC C) (3/2")  
AND FRICTION COURSE FC-5 (3/4") (RUBBER)

\* PROVIDES FOR 8' OF USABLE SHOULDER

\*\* THE 30' MEDIAN AREA PROVIDES SUFFICIENT WIDTH FOR:  
- 24' CLEAR ZONE  
- DUAL LEFT TURN LANES (11' lanes, 4' separator in median shoulder)  
- DIRECTIONAL MEDIAN OPENING (4' separators in median shoulder)

\*\*\* TURF OR SOD

EXHIBIT TYP-16  
Date: 1/1/08

| REVISIONS |             | STATE OF FLORIDA<br>DEPARTMENT OF TRANSPORTATION |             |                        | SHEET NO.       |
|-----------|-------------|--|-------------|------------------------|-----------------|
| DATE      | DESCRIPTION | DATE   | DESCRIPTION | FINANCIAL PROJECT ID   |                 |
|           |             |  |             | 10 LEON 123456-1-52-01 | TYPICAL SECTION |
|           |             |  |             |                        |                 |

#USERS #DATES #TIMES #FILES

NOTICE: THE OFFICIAL RECORD OF THIS SHEET IS THE ELECTRONIC FILE SIGNED AND SEALED UNDER RULE 6805-23.003, F.A.C.

## Chapter 7

### Summary of Quantities

|             |  |     |
|-------------|--|-----|
| 7.1         | General .....  | 7-1 |
| 7.2         | Item Quantity "Boxes" and Format .....               | 7-2 |
| 7.3         | Box Culvert Data Table .....                         | 7-3 |
| Exhibits    |  |     |
| Exhibit 7-1 | Standard Notes for Summary of Quantities Sheet ..... | 7-5 |

**THIS PAGE LEFT BLANK INTENTIONALLY**

## Chapter 7

### Summary of Quantities

#### 7.1 General

The summary of quantities sheet shows individual summaries of guardrail, crash cushions, fence, turnouts, sodding, ditch pavement, side drains, mitered end sections, underdrains, and earthwork when applicable. The tabulation shall show location and quantities in the plan quantity column (P). The final quantity column (F) is reserved for construction and final estimates. As noted in **Chapter 4**, the necessary pay items and the quantities shall be shown on the summary of pay items sheet.

For examples of summary of quantities sheets see **Exhibits SQ-1 thru 4**.

## 7.2 Item Quantity "Boxes" and Format

The various "boxes" used for each type of summary are contained in the FDOT Engineering/CADD Systems Software. Each box is identified by the appropriate Form Number required for the Computation Book. The arrangement of these "boxes" on the sheet is dependent on the number used and the size each one must be to contain all of the necessary information.

On contracts with multiple Financial Project ID's or federal aid and non-federal aid quantities, provisions shall be made to tabulate and summarize their respective quantities.

Standard notes (see **Exhibit 7-1**) shall be shown under the appropriate box.

Applicable pay item notes, listed in **Exhibit 7-1**, shall also be included on this sheet.

## 7.3 Box Culvert Data Table

The structural design of box culverts may be done by computer program as described in **Chapter 33**.

The program is the **LRFD Box Culvert Program** and designs the culvert based on the details shown on **Index 289** of the **Design Standards**. When this program is used the Box Culvert Data Table (from the Structures Sitemenu CADD cells) and the Reinforcing Bar List shall be completed and placed on normally formatted plan sheets. These sheets should generally be placed, behind the drainage structure sheets in the contract plans.

**THIS PAGE LEFT BLANK INTENTIONALLY**

### **Exhibit 7-1 Standard Notes for Summary of Quantities Sheet Sheet 1 of 2**

Below are standard notes that should be used on the summary of quantities sheet, as applicable:

(Under Summary of Earthwork):

Earthwork has been calculated using the \_\_\_\_\_ base option. If another option is constructed, there shall be no revision to the earthwork quantities for which payment is made by plan quantity.

#### **Pay Item Notes**

1. 102- 1- Includes approximately \_\_\_\_\_ SY of Temporary Pavement.
2. 104- 13- 1 Based on replacement every 12 months.
3. 110- 86- All salvageable material designated to be delivered by the contractor shall be delivered to:

(Provide address of nearest FDOT Maintenance Yard.)

(On applicable Utility JPA plans, also include the following note):

All utility infrastructure designated in the utility plans to be salvaged and delivered by the contractor shall be delivered to:

(Provide applicable Utility/Agency Owner address.)

4. 334- 1 Includes \_\_\_\_\_ TN for turnouts, connections to existing drives, streets, etc., as directed by the Engineer.
5. 400- 1- 15 Includes \_\_\_\_\_ CY for miscellaneous construction, as directed by the Engineer.

6. (For new construction projects with Asphalt Base, Type B-12.5 Only):

520-1-7 or 520-1-10

Cost of asphalt curb pad and additional curb thickness required to be included in the cost of curb and gutter.

7. 536- 73- (To be used for the removal of existing guardrail when FDOT Maintenance wants materials).

Existing guardrail to be dismantled and stockpiled within the right of way in areas designated by the Engineer for removal by FDOT maintenance forces.

**Exhibit 7-1 Standard Notes for Summary of Quantities Sheet  
Sheet 2 of 2**

8. 538- 1- This is to include replacement of \_\_\_\_\_ panels, \_\_\_\_\_ regular posts and \_\_\_\_\_ special posts which have been determined to be non-salvageable. Additional posts and panels determined to be non-salvageable during resetting shall be paid for under 538-5 of the Specifications.
9. Temporary Turf: When required by the project design, these items shall be included in the cost of the Performance Turf items (Note: When 570-1-A items are used in the plans, 104-4 (Mowing) shall not be used). A pay item note should show the approximate quantities. For example:
  - 570- 1- 1 Includes approximately \_\_\_\_\_ SY Turf for temporary erosion control.
  - 570- 1- 2 Includes approximately \_\_\_\_\_ SY Sod for temporary erosion control.
10. 639- 2- 1 Payment shall be based on the linear feet of a single conductor.
11. The following pay item note should be shown in the Roadway Plans:
  - 710- The totals shown on the Summary of Roadway Pay Items are for painted pavement markings used for Maintenance of Traffic.

**SUMMARY OF PERFORMANCE TURF, SOD**

| LOCATION<br>STA. TO STA.   | SIDE | P    |      |      | F |   |    | FIELD BOOK<br>REFERENCE |
|----------------------------|------|------|------|------|---|---|----|-------------------------|
|                            |      | L    | W    | SY   | L | W | SY |                         |
| <i>NB I-00</i>             |      |      |      |      |   |   |    |                         |
| 570+00 - 580+62            | Med. | 1062 | 1.33 | 157  |   |   |    |                         |
| 570+00 - 574+57            | Rt.  | 457  | 1.33 | 68   |   |   |    |                         |
| 575+45 - 576+80            | Rt.  | 135  | 1.33 | 20   |   |   |    |                         |
| 576+80 - 579+95            | Rt.  | 315  | 56   | 1960 |   |   |    |                         |
| 579+95 - 580+62            | Rt.  | 67   | 32   | 238  |   |   |    |                         |
| 580+62 - 586+37            | Med. | 575  | 1.33 | 85   |   |   |    |                         |
| 580+62 - 586+37            | Rt.  | 575  | 1.33 | 85   |   |   |    |                         |
| <i>SB I-00</i>             |      |      |      |      |   |   |    |                         |
| 570+00 - 580+62            | Med. | 1062 | 1.33 | 157  |   |   |    |                         |
| 570+00 - 574+57            | Lt.  | 457  | 1.33 | 68   |   |   |    |                         |
| 575+45 - 577+25            | Lt.  | 180  | 1.33 | 27   |   |   |    |                         |
| 577+25 - 580+34            | Lt.  | 309  | 48   | 1648 |   |   |    |                         |
| 580+34 - 580+62            | Lt.  | 28   | 37   | 115  |   |   |    |                         |
| 580+62 - 586+37            | Med. | 575  | 1.33 | 85   |   |   |    |                         |
| 580+62 - 586+37            | Lt.  | 575  | 1.33 | 85   |   |   |    |                         |
| <i>RAMP A</i>              |      |      |      |      |   |   |    |                         |
| 182+99 - 187+24            | Lt.  | 425  | 1.33 | 63   |   |   |    |                         |
| 180+87 - 187+74            | Rt.  | 687  | 1.33 | 102  |   |   |    |                         |
| <i>RAMP B</i>              |      |      |      |      |   |   |    |                         |
| 276+62 - 281+75            | Lt.  | 513  | 1.33 | 76   |   |   |    |                         |
| 274+47 - 280+29            | Rt.  | 582  | 1.33 | 86   |   |   |    |                         |
| <i>RAMP C</i>              |      |      |      |      |   |   |    |                         |
| 382+45 - 386+88            | Rt.  | 443  | 1.33 | 65   |   |   |    |                         |
| 381+95 - 388+30            | Lt.  | 635  | 1.33 | 94   |   |   |    |                         |
| <i>RAMP D</i>              |      |      |      |      |   |   |    |                         |
| 481+05 - 485+63            | Lt.  | 458  | 1.33 | 68   |   |   |    |                         |
| 480+64 - 487+31            | Rt.  | 667  | 1.33 | 99   |   |   |    |                         |
| <i>DRAINAGE STRUCTURES</i> |      |      |      | 807  |   |   |    |                         |
| <i>PAVED DITCHES</i>       |      |      |      | 278  |   |   |    |                         |
| <i>TOTAL</i>               |      |      |      | 6536 |   |   |    |                         |

**SUMMARY OF SIDE DRAIN & MITERED END SECTIONS**

| STA. TO STA.      | SIDE | PIPE LENGTH (LF) |     |     |            |     | MES (EA) |     |     |     |     |
|-------------------|------|------------------|-----|-----|------------|-----|----------|-----|-----|-----|-----|
|                   |      | UP TO 24"        |     |     | 25" TO 36" |     | 15"      | 18" | 24" | 30" | 36" |
|                   |      | 15"              | 18" | 24" | 30"        | 36" |          |     |     |     |     |
| P 150+10 - 150+50 | Rt.  | 40               |     |     |            |     | 2        |     |     |     |     |
| F 160+85 - 161+21 | Lt.  |                  | 36  |     |            |     |          | 2   |     |     |     |
| P 176+36 - 176+78 | Lt.  |                  |     |     | 42         |     |          |     |     | 2   |     |
| F 181+46 - 181+98 | Rt.  |                  |     | 52  |            |     |          |     | 2   |     |     |
| P 192+46 - 192+82 | Lt.  | 36               |     |     |            |     | 2        |     |     |     |     |
| F 194+50 - 195+14 | Rt.  |                  |     |     |            | 64  |          |     |     | 2   |     |
| P                 |      |                  |     |     |            |     |          |     |     |     |     |
| F                 |      |                  |     |     |            |     |          |     |     |     |     |
| P                 |      |                  |     |     |            |     |          |     |     |     |     |
| F                 |      |                  |     |     |            |     |          |     |     |     |     |
| P                 |      |                  |     |     |            |     |          |     |     |     |     |
| UNIT QUANTITY     |      | 76               | 36  | 52  | 42         | 64  | 4        | 2   | 2   | 2   | 2   |
| PLAN QUANTITY     |      | 164              |     |     | 106        |     | 4        | 2   | 2   | 2   | 2   |
| FINAL QUANTITY    |      | 164              |     |     | 106        |     | 4        | 2   | 2   | 2   | 2   |

EXHIBIT SQ-1  
Date: 1/1/08

| REVISIONS |             |      |             | STATE OF FLORIDA<br>DEPARTMENT OF TRANSPORTATION |        |                      | SUMMARY OF QUANTITIES | SHEET NO. |
|-----------|-------------|------|-------------|--|--------|----------------------|-----------------------|-----------|
| DATE      | DESCRIPTION | DATE | DESCRIPTION | ROAD NO.   | COUNTY | FINANCIAL PROJECT ID |                       |           |
|           |             |      |             | 10   | LEON   | 123456-1-52-01       |                       |           |

#USERS #DATES #TIMES #FILES

NOTICE: THE OFFICIAL RECORD OF THIS SHEET IS THE ELECTRONIC FILE SIGNED AND SEALED UNDER RULE 68G5-23.003, F.A.C.

**SUMMARY OF GUARDRAIL**

| LOCATION     |      | GUARDRAIL (LF) |       |             |   |                             |   |                             |             |           |             | END ANCHORAGE ASSEMBLIES (EA) |    |          |   |         |   |          |   | REMARKS | FIELD BOOK REFERENCE |   |  |  |  |  |  |
|--------------|------|----------------|-------|-------------|---|-----------------------------|---|-----------------------------|-------------|-----------|-------------|-------------------------------|----|----------|---|---------|---|----------|---|---------|----------------------|---|--|--|--|--|--|
| STATION      | SIDE | ROADWAY        |       |             |   |                             |   | PEDESTRIAN SAFETY TREATMENT |             | RUB RAIL  |             | FLARED                        |    | PARALLEL |   | TYPE II |   | TYPE CRT |   |         |                      |   |  |  |  |  |  |
|              |      | ROADWAY        |       | DOUBLE FACE |   | MOD. THRIE BEAM DOUBLE FACE |   | P                           | F           | P         | F           | P                             | F  | P        | F | P       | F | P        | F |         |                      |   |  |  |  |  |  |
|              |      | P              | F     | P           | F | P                           | F |                             |             |           |             |                               |    |          |   |         |   |          |   |         |                      |   |  |  |  |  |  |
| FROM 600+50  | Rt.  | 87.5           |       |             |   |                             |   |                             | FROM        |           | FROM 600+70 |                               |    |          |   |         |   |          |   |         |                      |   |  |  |  |  |  |
| TO 601+37    |      |                |       |             |   |                             |   |                             |             | TO        |             | TO 601+20                     |    |          |   |         |   |          |   |         |                      |   |  |  |  |  |  |
| FROM 600+10  | Lt.  | 125.0          |       |             |   |                             |   |                             | FROM        |           | FROM        |                               |    |          |   |         |   |          |   |         |                      |   |  |  |  |  |  |
| TO 601+35    |      |                |       |             |   |                             |   |                             |             | TO        |             | TO                            |    |          |   |         |   |          |   |         |                      |   |  |  |  |  |  |
| FROM 602+25  | Rt.  | 100.0          |       |             |   |                             |   |                             | FROM 602+30 |           | FROM        |                               |    |          |   |         |   |          |   |         |                      |   |  |  |  |  |  |
| TO 603+25    |      |                |       |             |   |                             |   |                             |             | TO 603+00 |             | TO                            |    |          |   |         |   |          |   |         |                      |   |  |  |  |  |  |
| FROM 600+50  | Med. |                | 275.0 |             |   |                             |   |                             | FROM        |           | FROM        |                               |    |          |   |         |   |          |   |         |                      |   |  |  |  |  |  |
| TO 603+25    |      |                |       |             |   |                             |   |                             |             |           | TO          |                               | TO |          |   |         |   |          |   |         |                      |   |  |  |  |  |  |
| FROM 604+25  | Rt.  | 62.5           |       |             |   |                             |   |                             | FROM        |           | FROM        |                               |    |          |   |         |   |          |   |         |                      |   |  |  |  |  |  |
| TO 604+87    |      |                |       |             |   |                             |   |                             |             | TO        |             | TO                            |    |          |   |         |   |          |   |         |                      |   |  |  |  |  |  |
| FROM 602+45  | Lt.  | 75.0           |       |             |   |                             |   |                             | FROM        |           | FROM        |                               |    |          |   |         |   |          |   |         |                      |   |  |  |  |  |  |
| TO 603+20    |      |                |       |             |   |                             |   |                             |             | TO        |             | TO                            |    |          |   |         |   |          |   |         |                      |   |  |  |  |  |  |
| FROM 604+50  | Med. |                |       |             |   |                             |   | 150.0                       | FROM        |           | FROM        |                               |    |          |   |         |   |          |   |         |                      |   |  |  |  |  |  |
| TO 606+00    |      |                |       |             |   |                             |   |                             |             |           | TO          |                               | TO |          |   |         |   |          |   |         |                      |   |  |  |  |  |  |
| <b>TOTAL</b> |      |                | 450   |             |   | 275                         |   | 150                         |             |           |             |                               |    |          |   |         |   | 3        |   | 1       |                      | 7 |  |  |  |  |  |

**SUMMARY OF DITCH PAVEMENT AND PERFORMANCE TURF, SOD**

| LOCATION      | SIDE  | RIPRAP (SAND CEMENT) |      | RIPRAP (RUBBLE) |   | CONCRETE |   | PERF. TURF (SOD) |   | REMARKS | FIELD BOOK REFERENCE |
|---------------|-------|----------------------|------|-----------------|---|----------|---|------------------|---|---------|----------------------|
|               |       | CY                   |      | TN              |   | SY       |   | SY               |   |         |                      |
|               |       | P                    | F    | P               | F | P        | F | P                | F |         |                      |
| 128+17        | Lt    |                      | 21.6 |                 |   |          |   |                  |   |         |                      |
| 128+52        | Rt    |                      | 24.2 |                 |   |          |   |                  |   |         |                      |
| 137+12 (S-2)  | Lt    |                      |      |                 |   | 26       |   | 8                |   |         |                      |
| 156+14 (S-6)  | Lt    |                      |      |                 |   | 30       |   | 9                |   |         |                      |
| 158+00 (S-7)  | Lt/Rt |                      |      |                 |   | 96       |   | 42               |   |         |                      |
| 161+20 (S-9)  | Lt    |                      |      |                 |   | 40       |   | 10               |   |         |                      |
| 168+40 (S-12) | Rt    |                      |      |                 |   | 108      |   | 12               |   |         |                      |
| 172+87 (S-15) | Rt    |                      |      |                 |   | 56       |   | 10               |   |         |                      |
| 180+12 (S-17) | Lt    |                      |      |                 |   | 20       |   | 8                |   |         |                      |
| 182+57 (S-20) | Rt    |                      |      |                 |   | 20       |   | 7                |   |         |                      |
| <b>TOTAL</b>  |       |                      | 45.8 |                 |   | 396      |   | 106              |   |         |                      |

WHEN A PEDESTRIAN SAFETY TREATMENT, AND/OR RUB RAIL TREATMENT, IS TO BE PROVIDED FOR A RUN OF GUARDRAIL, THE BEGINNING AND END STATION IS TO BE NOTED AS SHOWN IN THE SUMMARY OF GUARDRAIL ABOVE. OTHERWISE, THESE COLUMNS MAY BE DELETED.

EXHIBIT SQ-2  
Date: 1/1/08

| REVISIONS |             |      |             | STATE OF FLORIDA<br>DEPARTMENT OF TRANSPORTATION |        |                      | SUMMARY OF QUANTITIES | SHEET NO. |
|-----------|-------------|------|-------------|--|--------|----------------------|-----------------------|-----------|
| DATE      | DESCRIPTION | DATE | DESCRIPTION | ROAD NO.   | COUNTY | FINANCIAL PROJECT ID |                       |           |
|           |             |      |             | 10   | LEON   | 123456-1-52-01       |                       |           |

NOTICE: THE OFFICIAL RECORD OF THIS SHEET IS THE ELECTRONIC FILE SIGNED AND SEALED UNDER RULE 6805-23.003, F.A.C.

| SUMMARY OF EARTHWORK                    |        |    |
|---|--------|----|
| DESCRIPTION                             | P      | F  |
|   | CY     | CY |
| ROADWAY EXCAVATION, MAINLINE            | 10,000 |    |
| ROADWAY EXCAVATION, ADAMS ST.           | 800    |    |
| REGULAR EXCAVATION, POND #1             | 1,005  |    |
| REGULAR EXCAVATION FROM LATERAL DITCHES | 5,000  |    |
| TOTAL REGULAR EXCAVATION                | 16,805 |    |
|   |        |    |
| EMBANKMENT, MAINLINE                    | 20,000 |    |
| EMBANKMENT, ADAMS ST.                   | 7,000  |    |
| TOTAL EMBANKMENT                        | 27,000 |    |
|   |        |    |
| SUBSOIL EXCAVATION, MAINLINE            | 2,080  |    |
| SUBSOIL EXCAVATION, ADAMS ST.           | 1,100  |    |
| TOTAL SUBSOIL EXCAVATION                | 3,180  |    |
|   |        |    |
|   |        |    |

| SUMMARY OF EARTHWORK               |      |    |
|------------------------------------|------|----|
| DESCRIPTION                        | P    | F  |
|                                    | CY   | CY |
| FILL, MAINLINE                     | 253  |    |
| FILL, GUARDRAIL LOCATIONS          | 70   |    |
| FILL, CROSS DRAINS                 | 100  |    |
| SUB-TOTAL FILL                     | 423  |    |
|                                    |      |    |
| FILL ADJUSTMENT (20%)(423 x 0.20)  | +85  |    |
| SUB-TOTAL WITH FILL ADJUSTMENT     | 508  |    |
|                                    |      |    |
| TRUCK ADJUSTMENT (25%)(571 x 0.25) | +127 |    |
| TOTAL BORROW EXCAVATION            | 635  |    |
|                                    |      |    |
|                                    |      |    |

Earthwork has been calculated using the \_\_\_\_\_ base option.  
 If another option is constructed, there shall be no revision to the  
 earthwork quantities for which payment is made by Plan Quantity.

FOR PROJECTS WITH CROSS SECTIONS

FOR PROJECTS WITHOUT CROSS SECTIONS  
 Adjustment percentages shown are for example only.  
 Contact District Materials Office or Construction  
 for actual percentages to be used for each project.

EXHIBIT SQ-3  
 Date: 1/1/08

| REVISIONS |             |      |             | STATE OF FLORIDA<br>DEPARTMENT OF TRANSPORTATION |        |                      | SUMMARY OF QUANTITIES | SHEET<br>NO. |
|-----------|-------------|------|-------------|--|--------|----------------------|-----------------------|--------------|
| DATE      | DESCRIPTION | DATE | DESCRIPTION | ROAD NO.   | COUNTY | FINANCIAL PROJECT ID |                       |              |
|           |             |      |             | 10   | LEON   | 123456-1-52-01       |                       |              |

#USERS #DATES #TIMES #FILES

**SUMMARY OF PERMANENT CRASH CUSHIONS**

| STATION      | SIDE | DESIGN SPEED | OPTIONS ALLOWED | TRANSITION REQUIRED Y/N | PAY ITEMS |   |           |   |          |   |           |   |  |
|--------------|------|--------------|-----------------|-------------------------|-----------|---|-----------|---|----------|---|-----------|---|--|
|              |      |              |                 |                         | 544-75-40 |   | 544-75-22 |   | 544-75-9 |   | 544-75-14 |   |  |
|              |      |              |                 |                         | P         | F | P         | F | P        | F | P         | F |  |
| 100+50       | Rt   | 60           | QuadGuard       | Y                       | 1         |   |           |   |          |   |           |   |  |
|              |      |              | TAU II          | Y                       |           |   |           |   |          |   |           |   |  |
|              |      |              | TRACC           | Y                       |           |   |           |   |          |   |           |   |  |
| 103+10       | Med  | 60           | WideTRACC       | Y                       |           |   | 1         |   |          |   |           |   |  |
| 110+65       | Med  | 60           | BRAKEMASTER     | N                       |           |   |           |   | 1        |   |           |   |  |
| 125+23       | Rt   | 70           | QuadGuard HS    | Y                       | 1         |   |           |   |          |   |           |   |  |
|              |      |              | TAU II          | Y                       |           |   |           |   |          |   |           |   |  |
|              |      |              | TRACC           | Y                       |           |   |           |   |          |   |           |   |  |
| 1175+15      | Rt   | 35           | QuadGuard       | Y                       |           |   |           |   |          |   |           | 1 |  |
| 1321+37      | Lt   | 50           | QuadGuard       | Y                       | 1         |   |           |   |          |   |           |   |  |
|              |      |              | TAU II          | Y                       |           |   |           |   |          |   |           |   |  |
| <b>Total</b> |      |              |                 |                         | <b>3</b>  |   | <b>1</b>  |   | <b>1</b> |   | <b>1</b>  |   |  |

EXHIBIT SQ-4  
Date: 1/1/08

| REVISIONS |             |      |             | STATE OF FLORIDA<br>DEPARTMENT OF TRANSPORTATION |        |                      | SUMMARY OF QUANTITIES | SHEET NO. |
|-----------|-------------|------|-------------|--|--------|----------------------|-----------------------|-----------|
| DATE      | DESCRIPTION | DATE | DESCRIPTION | ROAD NO.   | COUNTY | FINANCIAL PROJECT ID |                       |           |
|           |             |      |             | 10   | LEON   | 123456-1-52-01       |                       |           |

#USERS# #DATES# #TIMES# #FILES#

NOTICE: THE OFFICIAL RECORD OF THIS SHEET IS THE ELECTRONIC FILE SIGNED AND SEALED UNDER RULE 68G5-23.003, F.A.C.

## Chapter 8

### Summary of Drainage Structures and Optional Materials Tabulation

|       |                                     |     |
|-------|-------------------------------------|-----|
| 8.1   | Summary of Drainage Structures..... | 8-1 |
| 8.1.1 | Sheet Setup and Data.....           | 8-2 |
| 8.2   | Optional Materials Tabulation ..... | 8-4 |

**THIS PAGE LEFT BLANK INTENTIONALLY**

## Chapter 8

# Summary of Drainage Structures and Optional Materials Tabulation

### 8.1 Summary of Drainage Structures

The summary of drainage structures sheet shows the location, size, length, number and type of drainage structures used in a project. The sheet format is available in the FDOT Engineering/CADD Systems Software. Specific levels and fonts which shall be used are given in the FDOT ***CADD Production Criteria Handbook***.

For an illustration of the summary of drainage structures sheet, see ***Exhibit SDS-1a***.

## 8.1.1 Sheet Setup and Data

A summary of drainage structures shall be prepared and included in the plans. The structures shall be listed by structure number in numerical order. The location of each structure shall be identified by station along the construction centerline (**Exhibit SDS-1a**).

For storm and cross drains, the summary of drainage structures shall be tabulated by structure number, providing the station, size, length and incidental quantities appropriate for the material detailed in the plans. Optional culvert material will be provided and a tabulation form shall be prepared and included (see **Section 8.2**).

Various drainage elements shall be shown in columns. This information shall be obtained from drainage structure sheets and plan-profile sheets. The order in which the elements are listed should be as follows:

1. Pipe Sizes for
  - a. Storm and Cross Drains
  - b. Gutter Drain
2. Curb Inlets
3. Manholes
4. Junction Boxes
5. Ditch Bottom Inlets
6. Gutter Inlets
7. Flared End Sections
8. Mitered End Sections
9. Performance Turf, Sod
10. Class of Concrete
11. Reinforcing Steel
12. Riprap

The "Description" column shall be used to specify the type of structure, the outgoing pipe and the end treatment of that pipe, if applicable.

The remarks column shall contain all special notes pertaining to the structure. The "Final Quantity" line is for construction to use and shall be left blank.

On smaller projects the summary of quantities and the summary of drainage structures may be combined on one sheet.

It is recommended that structure numbers be established using the convention shown in the exhibits and described as follows:

1. For simple cross drains, one structure number is appropriate for the inlet and outlet treatments and the pipe.

Example #1 (cross drain w/o median inlet)

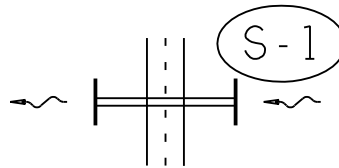

2. For complex cross drains, it is suggested that the first and all intermediate structure numbers identify the hydraulically upper end treatment and pipe. The last structure number should identify the hydraulically upper end treatment, pipe and hydraulically lower end treatment.

Example #2 (Double pipe cross drain and median inlet)

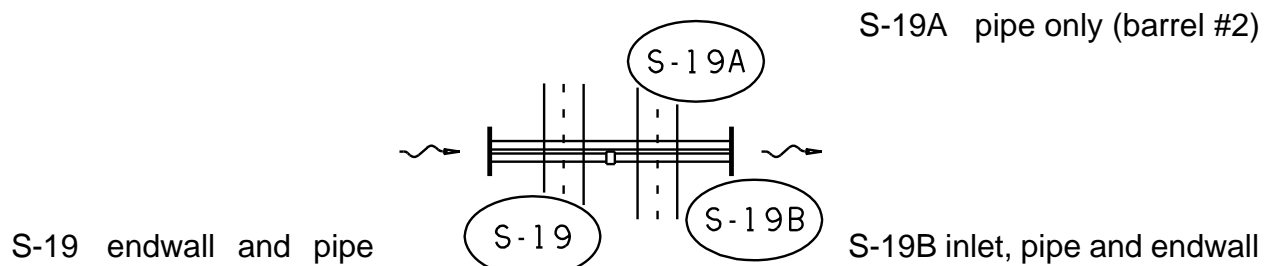

## 8.2 Optional Materials Tabulation

An optional materials tabulation shall be prepared and included in the plans (see **Exhibits SDS-2a** and **SDS-3a**). The sheet format is available in the FDOT Engineering Systems Software.

As a minimum, the optional pipe material tabulation should include size, thickness or class, corrugation requirements, if necessary, and protective coating, if any. Additional information such as structure number, design service life (DSL), length, and flow line information may be included.

The general notes shown on the exhibits are also required.



GENERAL NOTES

- The Contractor may use any of the optional pipe materials tabulated for a given structure. Only the material options tabulated for a given structure can be used.
- Adjustment to the bid quantities, prices and payment will not be allowed due to increase or decrease in structure size, shape, length, width, depth or accessory construction necessary to accommodate the use of an optional pipe material other than the "plotted" option; likewise there will be no added or reduced compensation for structure alterations required to relieve utility conflicts which arise from the use of an optional material other than the "plotted" option.
- Adjustment to the bid quantities, prices and payment will not be allowed due to increased or decreased excavation, bedding, borrow, backfilling, compaction, special installation requirements or disposal of excess materials due to use of any of the pipe optional materials. Likewise, adjustment in the quantities, prices and payment will not be allowed due to differences in end treatment size or types, pipe length, alternate jointing and connecting materials, saddles, cradles, filter fabrics, shoring or similar features due to the use of an optional material other than the "plotted" option.
- If adjustments are required due to plan errors or omissions or authorized field changes, the "plotted" material and not the material elected by the Contractor would be used to establish new pay quantities.
- The Contractor shall notify the Department in writing as to which optional pipe materials he chooses to use at the preconstruction conference. Once identified the Contractor may not change pipe material selected without the approval of the Engineer.
- Pipe shapes other than round (Elliptical/Arch) are summarized and paid for using equivalent round pipe diameter.

THIS EXAMPLE SHOULD BE USED WHEN PIPE FLOW LINES, AND/OR SIZES FOR INDIVIDUAL OPTIONS ARE NOT THE SAME (SEE STRUCTURE NO. 14) OR WHEN NUMEROUS EXCEPTIONS OCCUR.

| STR. NO. | DSL YEARS | SIZE (Inches)  | PLOTTED | MATERIAL & THICKNESS  | FL   | FL   | AS BUILT | REMARKS |
|----------|-----------|----------------|---------|---|------|------|----------|---------|
| 1        | 100       | 18             | X       | NRCP CLASS II<br>FRCP CLASS II  |      |      |          |         |
| 2        | 100       | 18             | X       | SRCP CLASS II<br>NRCP CLASS II<br>FRCP CLASS II   |      |      |          |         |
| 3        | 100       | 15             | X       | SRCP CLASS II<br>NRCP CLASS II<br>FRCP CLASS II<br>SRAP, 14 GA.   | 7.0  |      |          |         |
| 4        | 100       | 36             | X       | SRCP CLASS II<br>NRCP CLASS II<br>FRCP CLASS II   | 6.5  | 6.5  |          |         |
| 5        | 100       | 42             | X       | SRCP CLASS II<br>SRAP, 12 GA.<br>SRSP, 16 GA.   | 7.9  | 7.7  |          |         |
| 6        | 100       | 30             | X       | SRCP CLASS II<br>NRCP CLASS II<br>FRCP CLASS II<br>SRAP, 16 GA.<br>SRSP, 16 GA.                           | 6.8  | 6.5  |          |         |
| 7        | 100       | 18             | X       | SRCP CLASS II<br>NRCP CLASS II<br>FRCP CLASS II<br>SRAP, 16 GA.<br>SRSP, 14 GA.<br>SRASP, 16 GA.          | 7.6  | 7.2  |          |         |
| 8        | 100       | 18             | X       | SRCP CLASS II<br>NRCP CLASS II<br>FRCP CLASS II<br>SRAP, 16 GA.<br>SRSP, 14 GA.<br>SRASP, 16 GA.          | 8.0  | 7.6  |          |         |
| 9        | 100       | 24             | X       | SRCP CLASS III<br>NRCP CLASS III<br>FRCP CLASS III  |      |      |          | ENDWALL |
| 10       | 100       | 24x38<br>35x24 | X       | ERCP CLASS II<br>SRCP CLASS III<br>NRCP CLASS III   | 10.4 | 10.3 |          |         |
| 11       | 50        | 30             | X       | FRCP CLASS III<br>SRASP, 14 GA.<br>SRAP, 14 GA.<br>PEP-1<br>PVC<br>CAP, 16 GA.<br>CSP, 16 GA. BIT. COATED | 6.0  | 5.9  |          |         |
| 11-A     | 50        | 19x30<br>28x20 | X       | ERCP CLASS III<br>ASPA 14 GA.   | 5.9  | 5.8  |          |         |

EXHIBIT SDS-2a  
Date: 1/1/08

| REVISIONS |             |      |             | STATE OF FLORIDA<br>DEPARTMENT OF TRANSPORTATION |        |                      | OPTIONAL MATERIALS<br>TABULATION | SHEET NO. |
|-----------|-------------|------|-------------|--|--------|----------------------|----------------------------------|-----------|
| DATE      | DESCRIPTION | DATE | DESCRIPTION | ROAD NO.   | COUNTY | FINANCIAL PROJECT ID |                                  |           |
|           |             |      |             | 10   | LEON   | 123456-1-52-01       |                                  |           |

#USERS #DATES #TIMES #FILES

GENERAL NOTES

1. The Contractor may use any of the optional pipe materials tabulated for a given structure. Only the material options tabulated for a given structure can be used.
2. Adjustment to the bid quantities, prices and payment will not be allowed due to increase or decrease in structure size, shape, length, width, depth or accessory construction necessary to accommodate the use of an optional pipe material other than the "plotted" option; likewise there will be no added or reduced compensation for structure alterations required to relieve utility conflicts which arise from the use of an optional material other than the "plotted" option.
3. Adjustment to the bid quantities, prices and payment will not be allowed due to increased or decreased excavation, bedding, borrow, backfilling, compaction, special installation requirements or disposal of excess materials due to use of any of the pipe optional materials. Likewise, adjustment in the quantities, prices and payment will not be allowed due to differences in end treatment size or types, pipe length, alternate jointing and connecting materials, saddles, cradles, filter fabrics, shoring or similar features due to the use of an optional material other than the "plotted" option.
4. If adjustments are required due to plan errors or omissions or authorized field changes, the "plotted" material and not the material elected by the Contractor would be used to establish new pay quantities.
5. The Contractor shall notify the Department in writing as to which optional pipe materials he chooses to use at the preconstruction conference. Once identified the Contractor may not change pipe material selected without the approval of the Engineer.
6. Pipe shapes other than round (Elliptical/Arch) are summarized and paid for using equivalent round pipe diameter.

THIS EXAMPLE SHOULD BE USED WHEN MATERIAL OPTIONS ARE THE SAME FOR THE DIFFERENT PIPE SIZES AND WHEN LIMITED EXCEPTIONS ARE NOTED.

| STRUCTURE      | SIZE (Inches) | MATERIAL        | PLOTTED | AS BUILT | REMARKS |
|----------------|---------------|-----------------|---------|----------|---------|
|                | 15            | SRCP CLASS II   | X       |          |         |
|                |               | NRCP CLASS II   |         |          |         |
|                |               | FRCP CLASS II   |         |          |         |
|                |               | SRAP, 14 GA.    |         |          |         |
| EXCEPTION      | 18            | SRCP CLASS II   | X       |          |         |
| S-1            |               | NRCP CLASS II   |         |          |         |
| NRCP CLASS II  |               | FRCP CLASS II   |         |          |         |
| FRCP CLASS II  |               | SRAP, 16 GA.    |         |          |         |
| ONLY           |               | SRASP, 14 GA.   |         |          |         |
|                |               | SRASP, 16 GA.   |         |          |         |
| S-2            |               |                 |         |          |         |
| SRCP CLASS II  |               |                 |         |          |         |
| NRCP CLASS II  |               |                 |         |          |         |
| FRCP CLASS II  |               |                 |         |          |         |
| ONLY           |               |                 |         |          |         |
| EXCEPTION      | 24            | SRCP CLASS III  | X       |          |         |
| S-12           |               | NRCP CLASS III  |         |          |         |
| SRCP CLASS III |               | FRCP CLASS III  |         |          |         |
| ONLY           |               | SRAP, 16 GA.    |         |          |         |
|                |               | SRASP, 16 GA.   |         |          |         |
|                | 30            | SRCP CLASS III  | X       |          |         |
|                |               | NRCP CLASS III  |         |          |         |
|                |               | FRCP CLASS III  |         |          |         |
|                |               | SRAP, 14 GA.    |         |          |         |
|                |               | SRASP, 14 GA.   |         |          |         |
| EXCEPTION      | 36            | SRCP CLASS II   | X       |          |         |
| S-7            |               | NRCP CLASS II   |         |          |         |
| SRCP CLASS II  |               | FRCP CLASS II   |         |          |         |
| NRCP CLASS II  |               | SRAP, 14 GA.    |         |          |         |
| FRCP CLASS II  |               | SRASP, 12 GA.   |         |          |         |
| ONLY           |               | SRASP, 16 GA.   |         |          |         |
| EXCEPTION      | 24x38         | ERCP, CLASS II  | X       |          |         |
| S-13           | 35x24         | ASPA, 14 GA.    |         |          |         |
| EXCEPTION      | 19x30         | ERCP, CLASS III | X       |          |         |
| S-14-A         | 28x20         | ASPA, 14 GA.    |         |          |         |

EXHIBIT SDS-3a  
Date: 1/1/08

| REVISIONS |             |      |             | STATE OF FLORIDA<br>DEPARTMENT OF TRANSPORTATION |        |                      | OPTIONAL MATERIALS<br>TABULATION | SHEET<br>NO. |
|-----------|-------------|------|-------------|--|--------|----------------------|----------------------------------|--------------|
| DATE      | DESCRIPTION | DATE | DESCRIPTION | ROAD NO.   | COUNTY | FINANCIAL PROJECT ID |                                  |              |
|           |             |      |             | 10   | LEON   | 123451-1-52-01       |                                  |              |

#USERS

#DATES

#TIMES

#FILES



### **9.3 Survey Reference Points**

Generally, survey reference points should be shown on the project layout sheet just beneath the alignment sheet sequence plan or where other space allows. Baseline survey and reference points, with all ties, shall be clearly indicated. Complete length of survey baseline between two consecutive reference points need not be shown. Each reference point shall be clearly labeled, beginning at the first reference point within the limits of the project, and progressing in the direction of stationing. Usually, reference points need not be drawn to any particular scale, but distances and angles shown shall be proportionate. Care should be taken to ensure that clarity and legibility are maintained.

## 9.4 General Notes

When the layout sheet is included in the plans set, applicable general notes should be included on the layout sheet instead of the first plan-profile sheet to help simplify the plan-profile sheets. If the general notes for the project are numerous enough that putting them on the layout sheet (or the first plan sheet) becomes prohibitive, then a separate General Notes Sheet may be used (See **Exhibit GN-1**).

Refer to **Section 10.4** and **Exhibit 10-1** in **Chapter 10** of this volume for general note requirements and a list of standard general notes.



CURVE DATA CLCONST2  
 P1 STA. = 128+57.10  
 DELTA = 5° 55' 58" (LT)  
 D = 0° 45' 00"  
 T = 395.87  
 L = 791.02  
 R = 7,639.44  
 PRC STA. = 124+61.24  
 PT STA. = 132+52.26

STA. 131+77.73 @ CONST. =  
 STA. 50+30.36 @ N LAUREN PL.  
 EQUATION  
 PT STA. 132+52.26 @ CONST. BK. =  
 STA. 32+50.03 @ SURVEY AHD. =  
 STA. 132+50.03 @ CONST. AHD. =

STA. 133+60.02 @ CONST.  
 GULF RAILWAY  
 CROSSING NO. 620179

STA. 33+60.30 @ SURVEY  
 GULF RAILWAY  
 CROSSING NO. 620179

STA. 135+11.97 @ CONST. =  
 STA. 30+30.00 @ S GABRIEL CT.

STA. 137+59.82 @ CONST. =  
 STA. 30+03.39 @ JULIA AVE. RELOCATION

END PROJECT 123456-1-52-01  
 STA. 154+85.00  
 BEGIN PROJECT 123457-1-52-01

STA. 153+89.25 @ CONST. =  
 STA. 30+30.00 @ N LILA AVE.

STA. 144+93.41 @ CONST. =  
 STA. 30+30.00 @ N RAEA AVE.

STA. 44+93.82 @ SURVEY =  
 STA. 30+00.00 @ N RAEA AVE.

STA. 44+46.95 @ SURVEY =  
 STA. 30+00.00 @ S RAEA AVE.

STA. 53+89.36 @ SURVEY =  
 STA. 30+00.00 @ N LILA AVE.

STA. 31+75.74 @ SURVEY =  
 STA. 50+00.00 @ N LAUREN PL.

STA. 144+47.77 @ CONST. =  
 STA. 30+30.01 @ S RAEA AVE.

STA. 37+66.86 @ CONST. =  
 STA. 29+72.69 @ JULIA AVE.

STA. 36+29.44 @ SURVEY =  
 STA. 20+00.00 @ SURVEY LATERAL DITCH

CURVE DATA CLCONST  
 P1 STA. = 122+51.62  
 DELTA = 6° 17' 42" (RT)  
 D = 1° 30' 00"  
 T = 210.04  
 L = 419.65  
 R = 3,819.50  
 PC STA. = 120+41.58  
 PT STA. = 124+61.23

BEGIN PROJECT 123456-1-52-01  
 STA. 120+26.44  
 END PROJECT 123455-1-52-01

STA. 131+77.36 @ CONST.  
 STA. 50+30.36 @ S LAUREN PL.

STA. 125+63.48 @ CONST. =  
 STA. 30+61.04 @ DIANE ST.

STA. 119+99.23 @ CONST. =  
 STA. 451+67.01 @ CR 70

N 89° 38' 15" E

N 90° 00' 00" E

EVAN FRANCIS BLVD.

STA. 20+00.05 @ SURVEY =  
 STA. 450+75.98 @ CR 70

STA. 25+62.77 @ SURVEY =  
 STA. 30+00.00 @ DIANE ST.

STA. 31+75.39 @ SURVEY  
 STA. 50+00.00 @ S LAUREN PL.

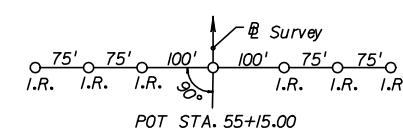
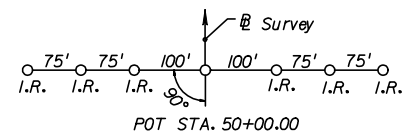
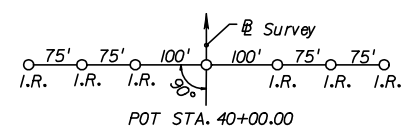
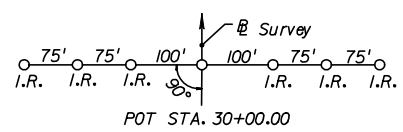
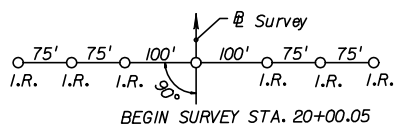

EXHIBIT: EX-PL-1  
 DATE: 1/1/08

| REVISIONS |             |      |             | STATE OF FLORIDA<br>DEPARTMENT OF TRANSPORTATION |        |                      | PROJECT LAYOUT | SHEET NO. |
|-----------|-------------|------|-------------|--|--------|----------------------|----------------|-----------|
| DATE      | DESCRIPTION | DATE | DESCRIPTION | ROAD NO.   | COUNTY | FINANCIAL PROJECT ID |                |           |
|           |             |      |             |  | LEON   | 123456-1-52-01       |                |           |

#USERS #DATES #TIMES #FILES

NOTICE: THE OFFICIAL RECORD OF THIS SHEET IS THE ELECTRONIC FILE SIGNED AND SEALED UNDER RULE 6805-23.003, F.A.C.

GENERAL NOTES

1. BENCHMARK ELEVATIONS SHOWN ON THE PLANS ARE NORTH AMERICAN VERTICAL DATUM OF 1988 (NAVD 88)
2. BUILDINGS TO BE REMOVED BY OTHERS, UNLESS OTHERWISE NOTED.
3. EXISTING DRAINAGE STRUCTURES WITHIN CONSTRUCTION LIMITS SHALL REMAIN UNLESS OTHERWISE NOTED.
4. THE LOCATION(S) OF THE UTILITIES SHOWN IN THE PLANS (INCLUDING THOSE DESIGNATED Vv, Vh, AND Vvh) ARE BASED ON LIMITED INVESTIGATION TECHNIQUES AND SHOULD BE CONSIDERED APPROXIMATE ONLY. THE VERIFIED LOCATIONS/ELEVATIONS APPLY ONLY AT THE POINTS SHOWN. INTERPOLATIONS BETWEEN THESE POINTS HAVE NOT BEEN VERIFIED.
5. EXISTING UTILITIES ARE TO REMAIN IN PLACE UNLESS OTHERWISE NOTED.
6. UTILITY/AGENCY OWNERS:
 

| COMPANY                       | CONTACT        | TELEPHONE NUMBERS |
|-------------------------------|----------------|-------------------|
| SPRINT/FLORIDA, INC.          | CHERYL FLORES  | (850) 555-1234    |
| QWEST                         | JIM WEST       | (850) 555-2345    |
| MC I WORLDCOM                 | ANDY WORLEY    | (407) 555-3456    |
| SPRINT COMMUNICATIONS         | ROB SPRINTER   | (404) 555-4567    |
| CITY OF TALLAHASSEE UTILITIES | CHESTER DIGGER | (850) 555-5678    |
7. SPECIAL ATTENTION IS DIRECTED TO THE FACT THAT PORTIONS OF SOME DRAINAGE STRUCTURES EXTEND INTO THE STABILIZED PORTION OF THE ROADBED AND EXTREME CAUTION WILL BE NECESSARY IN STABILIZATION OPERATIONS AT THESE LOCATIONS.
8. ALL DRAINAGE STRUCTURES HAVE OPTIONAL MATERIALS. THE OPTIONAL MATERIALS TABULATION SHEET(S) SHOWS ALL MATERIALS ALLOWED AS WELL AS INDICATING WHICH MATERIAL IS PLOTTED ON THESE SHEETS AND USED AS THE BASIS FOR PAY QUANTITIES.
9. ANY PUBLIC LAND CORNER WITHIN THE LIMITS OF CONSTRUCTION IS TO BE PROTECTED. IF A CORNER MONUMENT IS IN DANGER OF BEING DESTROYED AND HAS NOT BEEN PROPERLY REFERENCED, THE ENGINEER SHOULD NOTIFY THE DISTRICT LOCATION SURVEYOR, WITHOUT DELAY, BY TELEPHONE.
10. EXISTING DRIVEWAYS WITHIN THE LIMITS OF THIS PROJECT ARE TO BE REPLACED AT THE SAME LOCATION AND WIDTH, UNLESS OTHERWISE SHOWN IN THE PLANS.

LIST ANY ABBREVIATIONS USED IN THE PLAN SET BUT NOT FOUND IN DESIGN STANDARDS, INDEX 001.

LIST OTHER SPECIAL PROJECT NOTES HERE (NOTES VARY PER DISTRICT)

NOTE: PLAN NOTES ARE INTENDED TO BE USED TO CLARIFY DESIGN DETAIL, CONSTRUCTION PRACTICES OR METHOD FOR PAYMENT. IN GENERAL, PLAN NOTES SHOULD BE KEPT TO A MINIMUM, ONLY THOSE NOTES THAT ARE JOB SPECIFIC SHOULD BE USED. PLAN NOTES SHOULD ONLY BE USED TO DETAIL UNIQUENESS AND NOT TO BROADEN OR CURTAIL REQUIREMENTS IN THE SPECIFICATIONS. NOTES THAT RESTATE THE STANDARD SPECIFICATIONS OR STANDARD INDEXES SHALL NOT BE USED. THIS WILL HELP TO PLACE PROPER EMPHASIS ON THOSE NOTES THAT ARE JOB SPECIFIC AND AVOID DISCREPANCY OF DOCUMENTS.

EXHIBIT GN-1  
DATE: 1/1/08

| REVISIONS |             |      |             | STATE OF FLORIDA<br>DEPARTMENT OF TRANSPORTATION |        |                      | <b>GENERAL NOTES</b> | SHEET<br>NO. |
|-----------|-------------|------|-------------|--|--------|----------------------|----------------------|--------------|
| DATE      | DESCRIPTION | DATE | DESCRIPTION | ROAD NO.   | COUNTY | FINANCIAL PROJECT ID |                      |              |
|           |             |      |             | 10   | LEON   | 123456-1-52-01       |                      |              |

## 10.2.6 Drainage Structures and Bridges

Proposed cross drain pipes and box and three-sided culverts shall be indicated in the plan by a symbol and identified by a drainage structure number. Cross drain pipe sizes and lengths shall be shown. (Box and three-sided culvert lengths shall be shown on the drainage structure sheets).

Box and three-sided culverts (single or multiple) of 20 feet total span or more between inside faces of end supports, measured along the center of the roadway, shall be designated as bridge culverts and shall be identified by both a bridge number and a drainage structure number. The beginning and ending stations (outside wall to outside wall) shall be flagged.

Proposed bridges and approach slabs shall be shown by simple outline. Bridges shall be identified by bridge number and their beginning and ending stations noted by station flags. The beginning and ending stations of approach slabs shall be noted.

A short section of lateral ditch/outfall centerline shall be shown, when appropriate, on the roadway plan-profile sheet, together with a note referring to lateral ditch/outfall sheets for details.

The proposed drainage system is indicated by showing storm drain pipes with a single line, and the outline of inlets, manholes and junction boxes. The outline of structure bottoms may be shown at the designer's discretion. The pipe size and length between structures shall be given. Structure numbers shall be provided for inlets, manholes, junction boxes and special structures.

## 10.2.7 Plan Layout

1. Right of way lines shall be shown. Right of way shall be dimensioned only if the applicable typical section shows a varying dimension from the baseline or centerline. Dimensions of the R/W line shall be from the centerline or baseline, if survey and construction lines are parallel; otherwise it shall be dimensioned from the construction centerline.
2. The showing of detailed information regarding median openings or intersections should be avoided when they are of a type that can be detailed and grouped on a separate sheet. When this is the case, median openings and intersections shall be identified by station location.

3. At locations along the alignment where traveled way dimensions change, or begin to change, the station and dimensions of the traveled way shall be shown.
4. Curb, curb and gutter, traffic separators, sidewalks, curb ramps, retaining walls, etc. shall be shown. Driveways shall be shown as required by **Volume I, Section 1.8**.
5. Stations of return points shall be shown in tabular form or shown on the plan, unless shown on an intersection detail sheet. Offsets shall also be shown, if not governed by a typical.
6. Station of radius points of traffic separator or median curb at median openings shall be shown in the plan. Elevation of these points shall also be shown if not shown in the intersection details sheet or unobtainable in plans.
7. Control radii for traffic turns that set median nose locations shall be indicated, unless shown on the intersection detail sheet.
8. Station of end of curb and gutter at side street intersections (when end is not at a return point) shall be shown with proposed gutter grade elevation of these points.
9. Limits of pavement and grading at side street intersections shall be indicated.
10. When incidental construction extends beyond the right of way lines, construction easements or license agreements may be required and should be shown on the plan sheets.
11. Limits of wetlands shall be shown based on permit or regulatory requirements.
12. All utilities shall be shown in the plan. All major utilities that have been field verified (see *Quality Level "A" locates*, **Volume I, Chapter 5**) shall be labeled in accordance with the following symbol:

$V_{vh}$  = Verified Vertical Elevation and Horizontal Location

Projects with minor utility work or impacts may include these features on the roadway plan or plan-profile sheets.

13. All traffic monitoring sites on or within one-half mile of the project shall be identified with the following notation:

Traffic Monitoring Site Number (XXXX)

Roadway Identifying Number (RCI Section #) Milepost (XX.XXX)

Site includes vehicle detectors in roadway and pedestal, pole or base mounted cabinet, buried cable, and solar power unit on right of way.

Inquiries about monitoring sites should be addressed to the Traffic Data Section Manager of the Transportation Statistics Section, Office of Planning.

### **10.3.5 Other Profile Features**

For rural construction projects, special ditches shall be indicated in the profile and labeled. Percent of ditch grade and a beginning or ending ditch PI with elevation and station plus shall be shown. For multi-lane divided projects, three special ditch grades (right and left roadway ditches and median ditch) sometimes occur at the same location. In such cases it may be advantageous to show the median ditch at a convenient location on the sheet with a separate elevation datum.

Uniform ditches of non-standard depth should be indicated by a dimension line in the lower portion of the grid and noted as a special ditch with location and depth, or they should be indicated by flagging the DPI's at each end with station elevation and side. Standard depth ditches are not shown.

Special gutter grades shall be shown in profile for cases where the gutter grades are not controlled by the typical section and no "special profiles" are included in the plans set.

Prolongations of gutter profile grades across street intersections shall be included on plan-profile sheets if an inlet is not provided before the intersection.

Storm drain pipes, inlets and manholes along the main line shall be shown. Pipes shall be noted by size. Proposed structures may be shown by structure number only. Flow line elevations shall be shown for all pipes entering and leaving the structure.

Proposed cross drain pipes and culverts shall be plotted. The section shall be shown at the correct location and elevation of the proposed structure crossing the centerline of construction. Cross drains shall be identified by structure number only.

Where the project overpasses a road or railroad, the cross section template of the road/railroad under the bridge shall be shown at the appropriate location in profile.

Except for transverse utilities, no underground utilities shall be shown in profile.

**THIS PAGE LEFT BLANK INTENTIONALLY**

## 10.4 General Notes for Roadway Plan and Roadway Plan-Profile Sheets

General notes are intended to be used to clarify design detail, construction practices or method for payment. General notes should be kept to a minimum. Only those notes that are job specific should be used. General notes should only be used to detail uniqueness and not to broaden or curtail requirements in the specifications. Notes that restate the standard specifications or standard indexes shall not be used. This will help to place proper emphasis on those notes that are job specific and avoid discrepancy of documents.

General notes for the project shall be placed on the left portion of the first plan-profile sheet if a project layout sheet is not included in the plans set, otherwise, they shall be included on the layout sheet. If the general notes for the project are numerous enough that putting them on the layout sheet (or the first plan sheet) becomes prohibitive, then a separate General Notes Sheet may be used (See **Exhibit GN-1**).

See **Exhibit 10-1** for a list of standard General Notes required.

### **Exhibit 10-1 General Notes for Roadway Plan and Roadway Plan-Profile Sheets**

1. (The bench mark datum used for the plans (NAVD 88 or other) shall be noted in the first General Note.)
2. Buildings to be removed by others, unless otherwise noted.
3. Existing drainage structures within construction limits shall (be removed/remain) unless otherwise noted.
4. (When there are no utility adjustment sheets in the plans, the notes shown in **Exhibit 20-1** shall be included here as part of the general notes).
5. (If there are no drainage structure sheets in the plans, the following notes shall be included in the general notes, if applicable):
  - a. Special attention is directed to the fact that portions of some drainage structures extend into the stabilized portion of the roadbed and extreme caution will be necessary in stabilization operations at these locations.
  - b. All drainage structures have optional materials. The Optional Materials Tabulation Sheet(s) shows all materials allowed as well as indicating which material is plotted on these sheets and used as the basis for pay quantities.
6. Any public land corner within the limits of construction is to be protected. If a corner monument is in danger of being destroyed and has not been properly referenced, the Engineer should notify the District Location Surveyor, without delay, by telephone.
7. Existing driveways within the limits of this project are to be replaced at the same location and width, unless otherwise shown in the plans.
8. (Any abbreviations used in the plans, that are not in **Index 001** of the **Design Standards**, shall be defined here as part of the general notes).

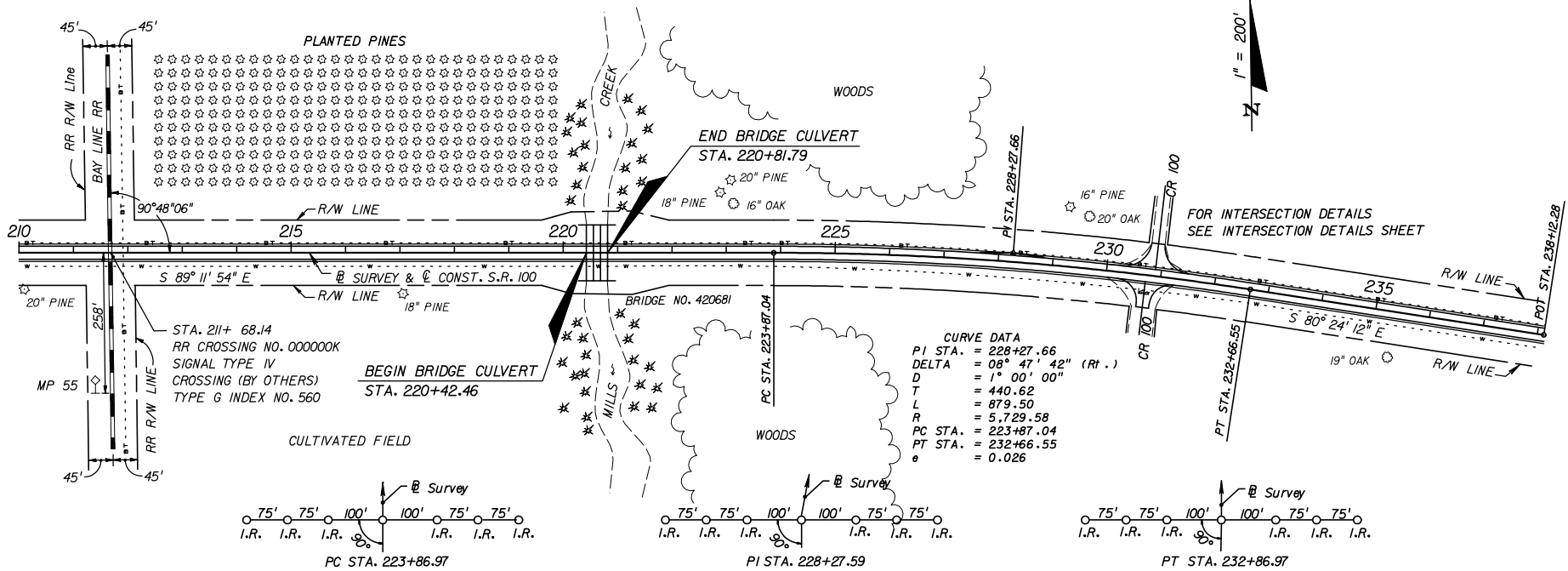

FOR INTERSECTION DETAILS  
 SEE INTERSECTION DETAILS SHEET

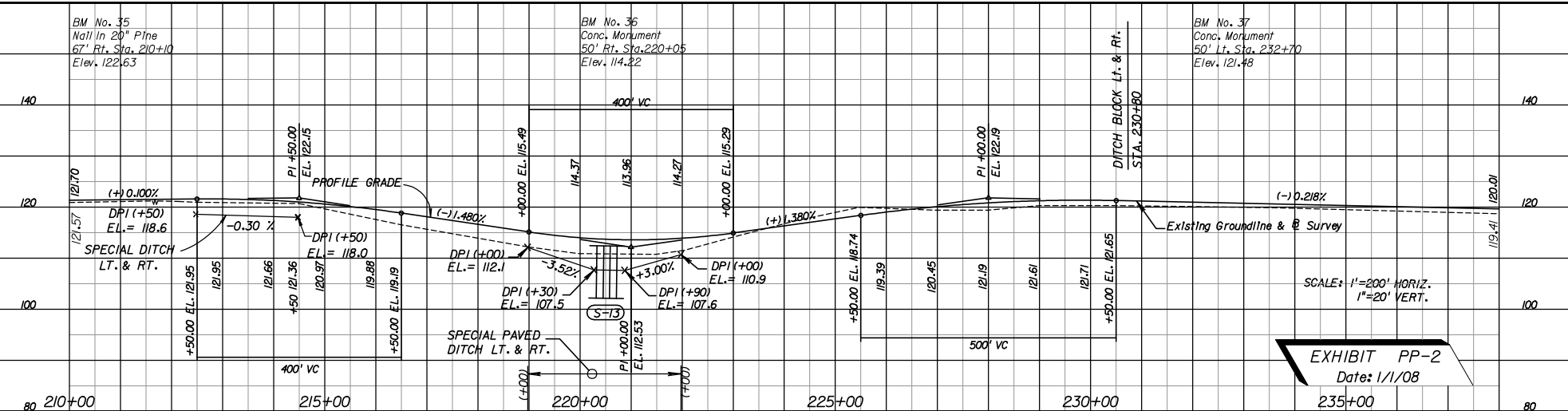

| REVISIONS |             |      |             |
|-----------|-------------|------|-------------|
| DATE      | DESCRIPTION | DATE | DESCRIPTION |
|           |             |      |             |

| STATE OF FLORIDA<br>DEPARTMENT OF TRANSPORTATION |        |                      |  |
|--|--------|----------------------|--|
| ROAD NO.   | COUNTY | FINANCIAL PROJECT ID |  |
| 10   | LEON   | 123456-1-52-01       |  |

**PLAN-PROFILE**

EXHIBIT PP-2  
Date: 1/1/08

NOTICE: THE OFFICIAL RECORD OF THIS SHEET IS THE ELECTRONIC FILE SIGNED AND SEALED UNDER RULE 6805-23.003, F.A.C.



# Chapter 14

## Drainage Structures

### 14.1 General

Drainage structure sheets show the drainage structures, their location, cross section, flow line elevations of all weirs or slots, top of grates, culverts and top of manhole elevations, and similar data. Drainage structure sheets also show the vertical relationships of the entire drainage system. During the process of design/placement of the drainage structures, potential conflicts with existing or proposed utilities shall be identified and resolved early, thereby avoiding costly time delays during the construction phases.

All projects require the plotting of drainage structures. When only cross drains are to be constructed or modified, drainage structures may be plotted on the cross section sheets. Otherwise drainage structures should be plotted on separate drainage structure sheets, utilizing the cross section sheet cell available in the FDOT Engineering/CADD Systems Software (see *Exhibit DS-2*). See *Chapter 22* for additional requirements for box and three-sided culverts utilized as drainage structures.

### 14.2 Required Information

The existing ground line for rural projects shall be shown at the location of the structure, with the existing elevation placed immediately below the ground line at the survey baseline. No existing structures shall be shown except those to be incorporated into the proposed drainage system or otherwise modified. These shall be shown and their flow line elevations noted. Where storm drains run laterally or diagonally across the project, the drawing should show the pipe cover.

The roadway template and proposed structures shall be shown, with the proposed profile grade elevation placed above the grade point. The structure shall be located by station and offset to the centerline of construction. Flow line information shall be provided at each structure and at each culvert end. Structures are to be plotted in detail according to the applicable index of the *Design Standards*, with walls, grates, tops, pipes, etc. shown.

Cross drain sections shall include the size and length for each proposed structure.

Sections for skewed cross drains shall be depicted along the centerline of the structure. Clear zone distances are to be measured at right angles to the traffic lane for all structures.

All structure locations should be checked and R/W shown where the R/W may have potential impact on construction of a structure.

For each drainage structure, all necessary information shall be shown by note, including, as appropriate: size, end treatment and flow lines, as well as structure, index and station number. The note shall be placed as close to the structure as possible, preferably below the plotted structure. Elevations shall be given for manhole tops, and ditch bottom inlet grates and slots. Grate elevations for gutter inlets and edge of pavement elevations for curb and gutter inlets shall be shown.

Alternate "G" or other special grate treatment shall be included with the inlet note. Additional details, such as special bedding, 36" manhole rings, etc., shall be indicated. Flow direction arrows shall be shown.

Material options shall be shown on the Optional Materials Tabulation Sheet. (See **Exhibits SDS-2a** and **SDS-3a** at the back of **Chapter 8** of this volume).

If existing structures are to be filled and/or plugged and are to remain in place, they should be shown in the plans with an appropriate note.

Applicable notes to be shown on the first drainage structure sheet are given in **Exhibit 14-1**.

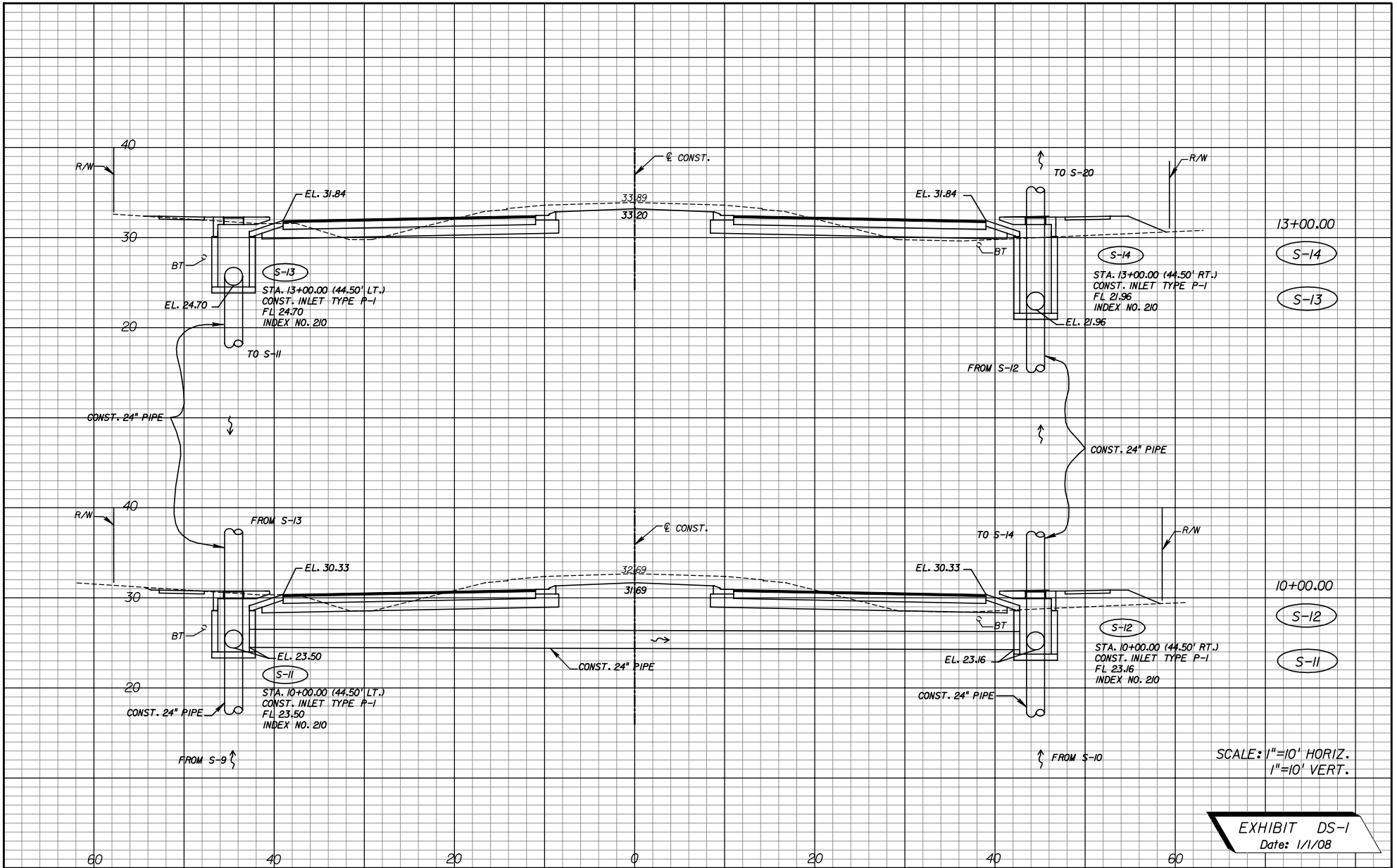

EXHIBIT DS-1  
Date: 1/1/08

| REVISIONS |             | STATE OF FLORIDA<br>DEPARTMENT OF TRANSPORTATION |             | SHEET NO. |
|-----------|-------------|--|-------------|-----------|
| DATE      | DESCRIPTION | DATE   | DESCRIPTION |           |
|           |             |  |             |           |

| ROAD NO. | COUNTY | FINANCIAL PROJECT ID | DRAINAGE STRUCTURES |
|----------|--------|----------------------|---------------------|
| 10       | LEON   | 123456-1-52-01       |                     |

NOTICE: THE OFFICIAL RECORD OF THIS SHEET IS THE ELECTRONIC FILE SIGNED AND SEALED UNDER RULE 68G5-23.003, F.A.C.

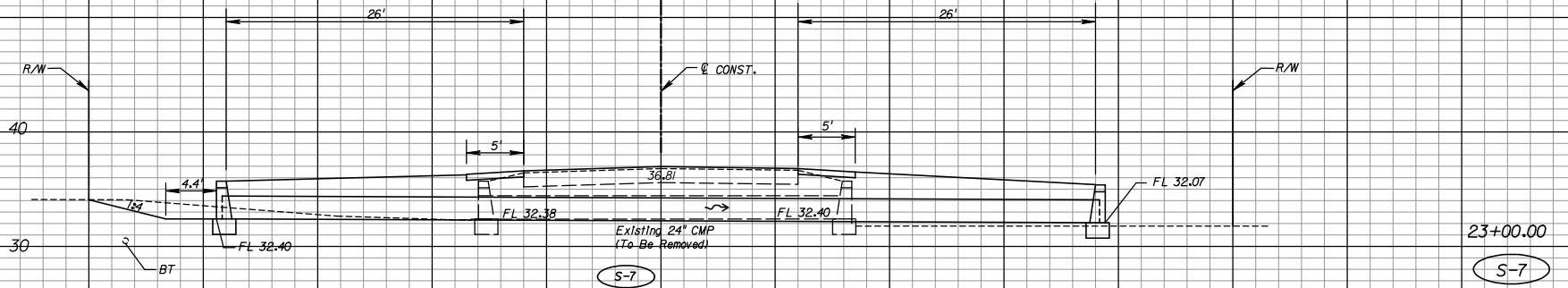

S-7  
 CONST. 77' OF 24" PIPE  
 W/STRAIGHT CONCRETE  
 ENDWALLS INDEX NO. 250

23+00.00  
 S-7

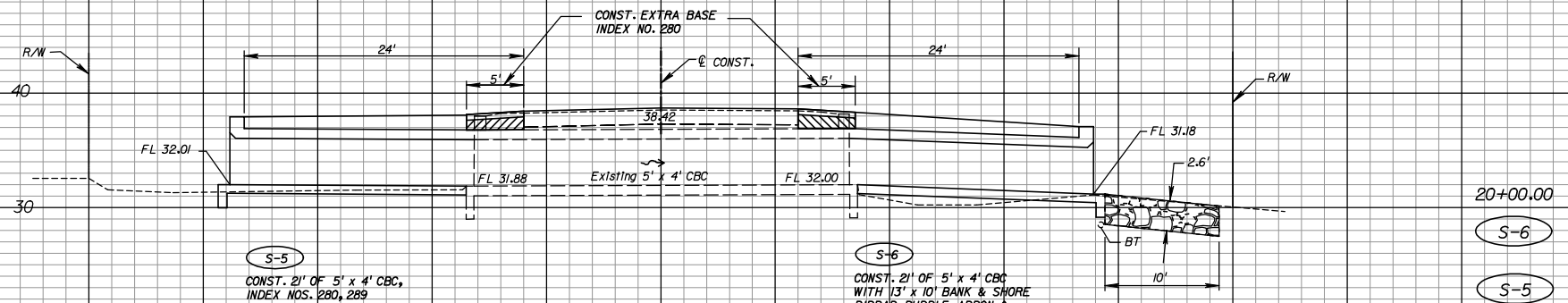

S-5  
 CONST. 21' OF 5' x 4' CBC,  
 INDEX NOS. 280, 289

S-6  
 CONST. 21' OF 5' x 4' CBC  
 WITH 13' x 10' BANK & SHORE  
 RIPRAP RUBBLE, APRON &  
 FILTER FABRIC  
 INDEX NOS. 280, 281, & 289

20+00.00  
 S-6  
 S-5

SCALE: 1"=10' HORIZ.  
 1"=10' VERT.

EXHIBIT DS-2  
 Date: 1/1/08

| DATE |  | DESCRIPTION |  | REVISIONS |  | DATE |  | DESCRIPTION |  |
|------|--|-------------|--|-----------|--|------|--|-------------|--|
|      |  |             |  |           |  |      |  |             |  |

|  |        |                      |
|--|--------|----------------------|
| STATE OF FLORIDA<br>DEPARTMENT OF TRANSPORTATION |        |                      |
| ROAD NO.   | COUNTY | FINANCIAL PROJECT ID |
| 10   | LEON   | 123456-1-52-01       |

|                     |           |
|---------------------|-----------|
| DRAINAGE STRUCTURES |           |
|                     | SHEET NO. |

NOTICE: THE OFFICIAL RECORD OF THIS SHEET IS THE ELECTRONIC FILE SIGNED AND SEALED UNDER RULE 6805-23.003, F.A.C.





## **Chapter 20**

### **Utility Adjustments**

#### **20.1 General**

The purpose of utility adjustment sheets is to provide coordination between the contractor and the affected utility companies. These sheets show the contractor the approximate locations of existing, proposed and relocated utilities, and thus aid the contractor in avoiding possible conflicts or damage to the utilities involved. Projects with minor utility work or impacts may include these features on the roadway plan or plan-profile sheets or appropriate component plan sheets.

## 20.2 Required Information

Locations of all existing and proposed utilities within the project limits shall be shown on the plans.

All proposed and relocated utilities shall be clearly shown on the plan using lines and standard utility symbols, and shall be labeled (see ***Index No. 002*** of the ***Design Standards*** and the ***FDOT CADD Production Criteria Handbook***). Disposition of all existing utilities that are not to remain in place and in service shall be clearly indicated: for example "To Be Removed", "To Be Adjusted", "To Be Relocated", etc. The disposition of existing utilities that are to remain in place and in service need not be labeled. All proposed utilities shall be appropriately labeled.

Applicable general notes shall also be shown on the first utility adjustment sheet (see ***Exhibit 20-1***).

**SELECTIVE CLEARING AND GRUBBING – GENERAL NOTES**

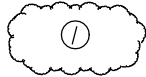

DESIGNATES AREAS TO REMAIN NATURAL. NO CLEARING OR GRUBBING IN THESE AREAS. NO EQUIPMENT SHALL ENTER THESE AREAS. NO STAGING, STORAGE OR DUMPING IN THIS AREA.



DESIGNATES AREAS WHERE TREES AND STUMPS OVER 3" IN DIAMETER SHALL BE CUT FLUSH WITH THE GROUND OR REMOVED, AND ALL UNDERGROWTH IS TO REMAIN NATURAL. NO EQUIPMENT SHALL ENTER THESE AREAS THAT WOULD IN ANY WAY DAMAGE THE PLANT MATERIAL TO REMAIN. NO STAGING, STORAGE, OR DUMPING IN THIS AREA.



DESIGNATES AREAS WHERE TREES OF 3" IN DIAMETER OR GREATER ARE TO REMAIN AND ALL UNDERGROWTH IS TO BE REMOVED. ONLY RUBBER TIRE EQUIPMENT SHALL ENTER THESE AREAS, AND REMAINING TREES SHALL BE PROTECTED FROM ROOT AND TRUNK DAMAGE. NO STAGING, STORAGE, OR DUMPING IN THIS AREA.



DESIGNATES AREAS WHERE THE TYPE AND EXTENT OF CLEARING AND GRUBBING SHALL BE DETERMINED BY THE ENGINEER ACCORDING TO FIELD CONDITIONS.



DESIGNATES AREAS THAT SHALL REMAIN NATURAL WHEN, IN THE OPINION OF THE ENGINEER, ADEQUATE AND DESIRABLE NATURAL VEGETATION OR GRASS EXIST. WHERE THIS TYPE VEGETATION DOES NOT EXIST, ONLY HARROWING, DISKING, LEVELING, AND/OR CLEAN-UP SHALL BE UNDERTAKEN, TO A DEGREE SUFFICIENT TO PREPARE THE AREA FOR GRASSING OPERATIONS.

AREAS WHERE EQUIPMENT IS NOT ALLOWED AND OTHER LOCATIONS, AS DIRECTED BY THE ENGINEER, THAT MUST BE PROTECTED BY TREE GUARDS. THE LOCATION FOR TREE GUARDS SHALL BE SHOWN IN THE PLANS.

ALL OTHER AREAS NOT INCLUDED IN ONE OF THE ABOVE CATEGORIES, OR THOSE DESIGNATED BY THE TYPICAL SECTIONS, SHALL BE STANDARD CLEARING AND GRUBBING.

WHERE UNFORESEEN SITE CONDITIONS EXIST, ADJUSTMENTS OR EXCEPTIONS MAY BE MADE TO THE ABOVE PROCEDURE AT THE DIRECTION OF THE ENGINEER.

**FINISH SOIL LAYER – GENERAL NOTES**

STOCKPILING OF FINISH SOIL LAYER MATERIAL IS TO BE DONE ONLY IN AREAS REQUIRING STANDARD CLEARING AND GRUBBING AND/OR AREAS DESIGNATED AS TYPE 5 (SEE SELECTIVE CLEARING AND GRUBBING – GENERAL NOTES).

TYPE 4 AREAS MAY BE USED FOR STOCKPILING OF FINISH SOIL LAYER MATERIAL ONLY WHERE SUCH AREAS HAVE BEEN CLEARED, AT THE DIRECTION OF THE ENGINEER DURING CONSTRUCTION OPERATIONS.

SUFFICIENT AREA HAS BEEN DESIGNATED SO THAT ALL STOCKPILING MAY BE DONE IN ACCORDANCE WITH THE REQUIREMENTS LISTED ABOVE.

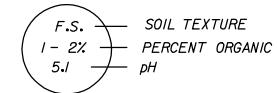

**SOIL INFORMATION DETAIL**

EXPLANATION OF SYMBOLS & SOIL TEXTURE ABBREVIATIONS

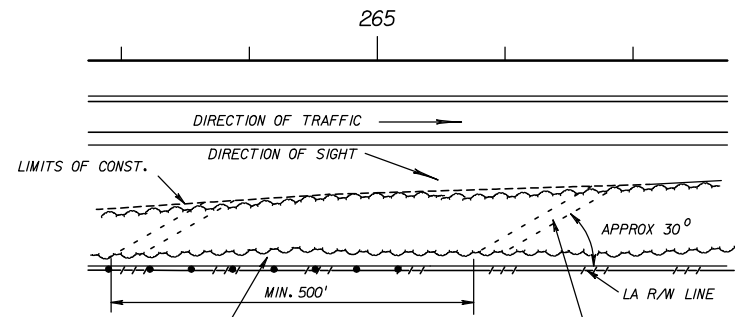

10' STRIP WHICH MAY BE CLEARED FOR FENCE CONSTRUCTION WITH SELECTED DESIRABLE TREES ALLOWED TO REMAIN, AS DIRECTED BY THE ENGINEER.

AT THE DIRECTION OF THE ENGINEER, DIAGONAL PATH MAY BE CUT IN AREAS TO REMAIN NATURAL, AS SHOWN ABOVE, FOR THE REMOVAL OF TIMBER AND STUMPS FROM THE AREA CLEARED FOR FENCE CONSTRUCTION.

**ACCESS FOR FENCE CONSTRUCTION**

(APPLIES TO ALL TYPES OF SELECTIVE CLEARING AND GRUBBING)

**EXHIBIT SCG-1**  
Date: 1/1/08

| REVISIONS |             |      |             | STATE OF FLORIDA<br>DEPARTMENT OF TRANSPORTATION |        |                      | SELECTIVE CLEARING AND<br>GRUBBING | SHEET<br>NO. |
|-----------|-------------|------|-------------|--|--------|----------------------|------------------------------------|--------------|
| DATE      | DESCRIPTION | DATE | DESCRIPTION | ROAD NO.   | COUNTY | FINANCIAL PROJECT ID |                                    |              |
|           |             |      |             | 10   | LEON   | 123456-1-52-01       |                                    |              |

#USERS #DATES #TIMES #FILES

NOTICE: THE OFFICIAL RECORD OF THIS SHEET IS THE ELECTRONIC FILE SIGNED AND SEALED UNDER RULE 6805-23.003, F.A.C.

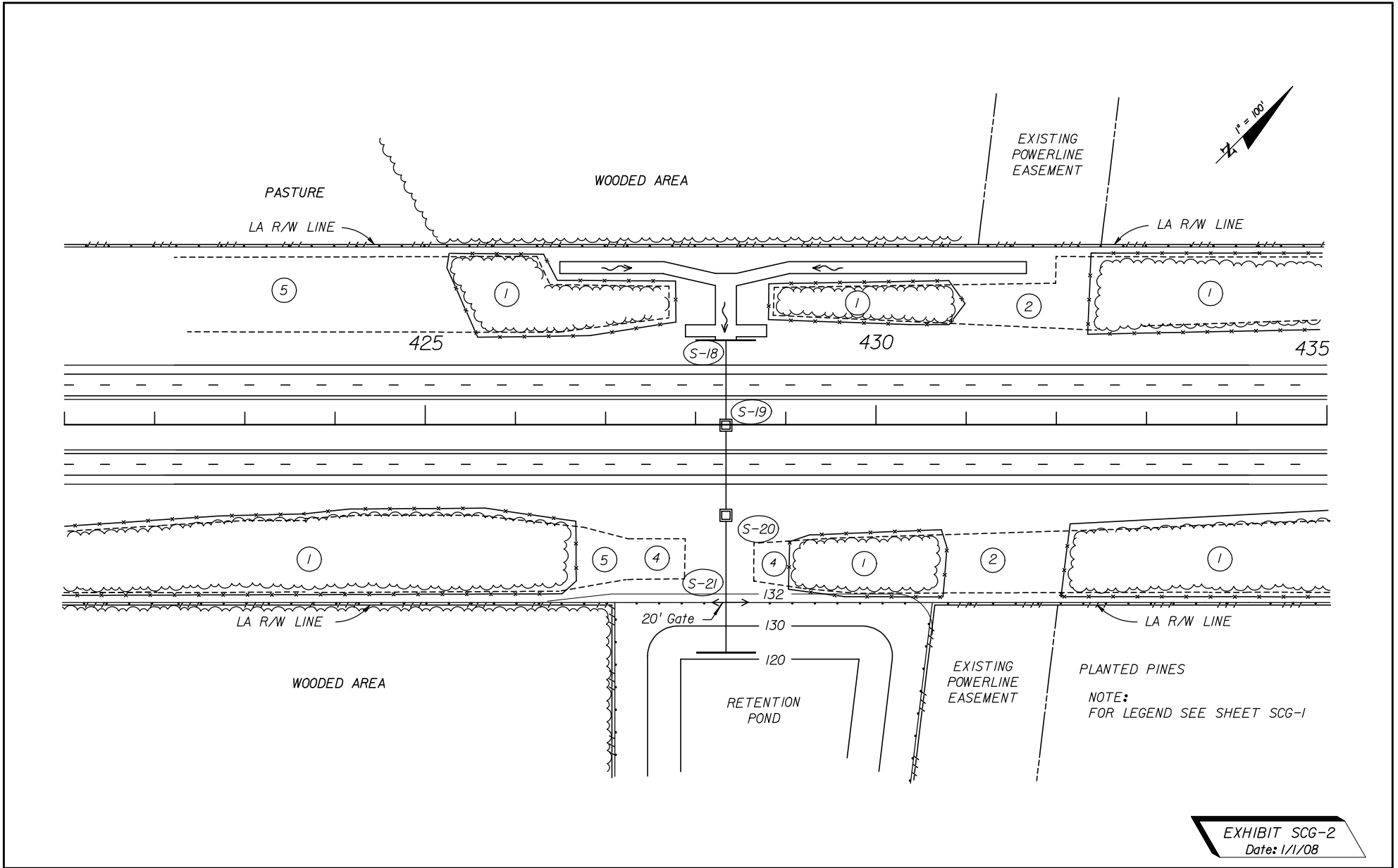

**EXHIBIT SCG-2**  
Date: 1/1/08

| REVISIONS |             |      |             | STATE OF FLORIDA<br>DEPARTMENT OF TRANSPORTATION | ROAD NO. | COUNTY | FINANCIAL PROJECT ID | SHEET NO. |
|-----------|-------------|------|-------------|--|----------|--------|----------------------|-----------|
| DATE      | DESCRIPTION | DATE | DESCRIPTION |  |          |        |                      |           |
|           |             |      |             |  |          |        |                      |           |

**SELECTIVE CLEARING AND GRUBBING**

NOTICE: THE OFFICIAL RECORD OF THIS SHEET IS THE ELECTRONIC FILE SIGNED AND SEALED UNDER RULE 6805-23.003, F.A.C.

## Chapter 22

### Miscellaneous Structures Plans

#### 22.1 General

Miscellaneous structures not included in the bridge plans shall be included in the appropriate component plans. This includes box or three-sided culvert details, high mast lighting supports, traffic mast arm supports, signal strain poles, overhead sign supports, rest area structures or buildings, barrier walls (traffic or sound), retaining walls and toll facilities. Box and three-sided culvert details should generally be placed immediately following the Drainage Structures sheets.

For guidelines on structural detailing, refer to the ***Structures Detailing Manual (Topic No. 625-020-200)***.

## **22.2 Approach Slabs**

As of the July, 1999 letting, approach slab details sheets are included in the structures plans. However, some roadway elements may need to be carried onto the approach slab, and in these cases special attention must be given to clarifying in the plans which elements are to be included as part of the roadway.

The stabilization required under the approach slabs shall be paid for using the standard roadway pay item and the quantity included in the roadway plans. In addition, roadway elements such as guardrail, earthwork, sidewalks, approach slab surfacing, etc., which are part of the roadway approaches to the bridge and which interface with the approach slabs areas, will also be included and paid for in the roadway quantities.

## 22.3 Retaining Walls (Cast in Place, Proprietary, Temporary)

When cast in place retaining walls other than standard gravity walls are required, complete design and construction details, including pay items and quantities are required in the contract plans. The same is true for steel or concrete sheet piles for either permanent or temporary retaining walls.

Proprietary walls are handled differently than cast in place, steel and concrete sheet pile retaining walls. A set of control plan details must be developed for retaining walls. (See **Chapter 30, Volume I** for a discussion concerning the requirements for control plan details).

On projects with bridges the control plan details shall be included in the bridge plans. When there are no bridge plans the control plan details shall be included in the appropriate component plans. Examples of control plan details are included as exhibits at the back of this chapter.

Standard drawings from the preapproved wall companies are included in the **Design Standards** (available as Interim Index Drawings).

## 22.4 Concrete Box Culverts

Complete design and construction details, including pay items and quantities are required in the contract plans for concrete box culverts. Include the following minimum design details:

1. Plan view (usually shown on the Plan-Profile sheet – see **Chapter 10, Exhibit PP-2**) showing: Grid north arrow; scale bar; existing highway boundaries including existing ROW monuments; new right of way line(s) including proposed ROW monuments; culvert or bridge identification number; culvert and highway alignment; survey baseline; profile grade line; direction of stationing; stream channel alignment; stream flow direction; skew angle of the culvert relative to the centerline of roadway; stationing along the profile grade line including begin and end station of culvert (outside face of sidewalls); length of culvert; subsurface exploration locations (e.g., boring locations); culvert end treatment (headwall and wing wall orientation); scour protection; slope protection; limit of stream work; utilities; traffic railing and pedestrian/bicycle railing type.
2. Elevation view (usually shown on the Plan-Profile sheet – see **Chapter 10, Exhibit PP-2**) showing: Elevation vertical scale; profile grade line and vertical data; existing stream bottom and ground line (along PGL); utilities.
3. A longitudinal section along the culvert centerline (usually shown on the Drainage Structures sheet – see **Chapter 14, Exhibit DS-2**) showing: Culvert or bridge identification number; invert elevations; existing stream bottom or original ground; culvert stationing at centerline; typical highway section (including rail treatment); design earth cover height (measured from the top of the top slab to the top of pavement); limits of scour protection (including any keyways or geotextile fabric lining); channel work; culvert end treatments; utility (either attached to the fascia, or in the embankment, traffic railing or sidewalk); wing walls; headwalls; cutoff walls; reference to the appropriate Design Standard Indexes.
4. Data Sheets (see **Chapter 7.3**):  
Box Culvert Data Table and Reinforcing Bar List.
5. Miscellaneous details showing (usually shown on Box Culvert Detail sheets, located after the Drainage Structure sheets): Construction phasing information (affects lengths of precast segments and potential need for skewed segments) including appropriate excavation support and protection systems (e.g., critical temporary walls); traffic railing details including connection details; slope and/or stream bank protection; channel section detail; culvert-end safety grate, guardrail or fencing details when applicable; removal of existing culvert(s); cofferdams or water diversion.

## Chapter 23

### Signing and Pavement Marking Plans

#### 23.1 General

Signing and pavement marking plans are usually a component set of plans. Projects with minor signing and pavement markings may include these features on sheets in the roadway plan set or detailed on roadway sheets. When prepared as component plans they shall be assembled as a separate plans set complete with a key sheet, tabulation of quantities and all other signing and pavement marking sheets. When prepared as component plans, the sheets shall be numbered consecutively with the sheet numbers prefixed by the letter “S”.

A complete set of signing and pavement marking plans shall include the following sheets:

1. Key Sheet
2. Tabulation of Quantities
3. Plan Sheets
4. Guide Sign worksheet (if required)
5. Overhead Sign Cross Section Sheet (if required)
6. Overhead Sign Support Design (if required)
7. Foundation Details (if required)
8. Boring Data Sheets (if required)

In addition, the signing and pavement marking plans may contain sheets which were prepared separately (perhaps by a sub-consultant) and incorporated into the signing and pavement marking plans early in the design process (prior to the establishment of sheet numbering). As an option, these may be identified with the following prefixes and placed at the end of the numbered sequence of the signing and pavement marking plans:

GS-#      Soil Survey and Report of Core Borings normally associated with the signing and pavement marking plans set (including miscellaneous structures but excluding bridges and walls)

Pavement marking material on projects that include new asphalt surfaces will generally be paint, rather than thermoplastic. This is based on the requirement of a 90-day curing

period for new asphalt. Thermoplastic markings on these projects must be placed using a separate contract. Exceptions must be coordinated with the District Construction Office.

**Section 23.9** provides guidance for preparation of separate plans for Thermoplastic Markings.

Thermoplastic may be called for in the plans on those projects that are exclusively of concrete pavement surfaces.

## 23.2 Key Sheet

The key sheet is the first sheet in the set and shall be prepared on a standard key sheet format as described in **Chapter 3** of this volume. Contract plans set information, location map and length of project box are not required on this sheet when shown on the lead key sheet. A complete index of signing and pavement marking plans shall be shown on the left side of the sheet.

Other data, including name, consultant contract number, vendor number, and certificate of authorization number of the firm (when plans are prepared by a consultant) shall be shown as described in **Chapter 3** of this volume.

If shop drawings are anticipated, the name(s) and address(es) of the Delegated Engineer(s) for shop drawing review(s) shall be shown on the right side of the sheet.

## Chapter 24

# Signalization Plans

### 24.1 General

Signalization Plans are usually a component set of plans. Projects with minor signalization may include these features on sheets in the roadway plans set or on the roadway sheets (or in another component plans set or on that component's sheets when appropriate). When prepared as component plans they shall be assembled as a separate plans set complete with a key sheet, tabulation of quantities and all other relevant signal sheets. When prepared as component plans, the sheets shall be numbered consecutively with the sheet numbers prefixed by the letter "T".

The signalization plans show the construction details, electrical circuits, signal phasing and other relevant data.

A complete set of signalization plans shall include the following sheets:

1. Key Sheet
2. Tabulation of Quantities
3. Plan Sheets
4. Mast Arm Details (if required)
5. Foundation Details - Mast Arms (if required)
6. Boring Data Sheets - Mast Arms (if required)

In addition, the signalization plans may contain sheets which were prepared separately (perhaps by a sub-consultant) and incorporated into the signalization plans early in the design process (prior to the establishment of sheet numbering). As an option, these may be identified with the following prefixes and placed at the end of the numbered sequence of the signalization plans:

- GT-# Soil Survey and Report of Core Borings normally associated with the signalization plans set
- PTM-# Portable Traffic Monitoring Site Sheets

## 24.2 Key Sheet

The key sheet is the first sheet in the component plans set and shall be prepared as described in **Chapter 3** of this volume. The location map, length of project box and contract plans set information are not required on this sheet when shown on the lead key sheet. The index of signalization plans shall be shown on the left of the sheet. Other data, including name, consultant contract number, vendor number, and certificate of authorization number of the firm (when plans are prepared by a consultant), shall be shown as described in **Chapter 3** of this volume.

If shop drawings are anticipated, the name(s) and address(es) of the Delegated Engineer(s) for shop drawing review(s) shall be shown on the right side of the sheet.

Following are examples for use with the Standard Mast Arm Assemblies Data Table:

**EXAMPLE 1**  
Single Arm Structure as shown, 110 mph Wind Speed with Signal Backplates.

**EXAMPLE 2**  
First Arm Structure as shown, Second Arm same as Example 1 except 150 mph Wind Speed with Signal Backplates.

| STANDARD MAST ARM ASSEMBLIES DATA TABLE |                                 |           |                          |                          |            |                          |                          |          |          |           |                          |          |                          |   |          |    |    |
|---|---------------------------------|-----------|--------------------------|--------------------------|------------|--------------------------|--------------------------|----------|----------|-----------|--------------------------|----------|--------------------------|---|----------|----|----|
| STRUCTURE ID NUMBERS                    | ASSEMBLY <sup>(1)</sup> NUMBERS | FIRST ARM |                          |                          | SECOND ARM |                          |                          | UF (deg) | LL (deg) | POLE      |                          |          |                          | SPECIAL DRILLED SHAFT DATA <sup>(4)</sup> |          |    |    |
|   |                                 | ARM TYPE  | FAA <sup>(2)</sup> (ft.) | FBA <sup>(2)</sup> (ft.) | ARM TYPE   | FAA <sup>(2)</sup> (ft.) | FBA <sup>(2)</sup> (ft.) |          |          | POLE TYPE | UAA <sup>(3)</sup> (ft.) | UB (ft.) | UCA <sup>(3)</sup> (ft.) | DA (ft.)                                  | DB (ft.) | RA | RB |
| Example 1                               | F1 - W1                         | F1        |                          |                          |            |                          |                          |          |          | W1        |                          | 22       |                          |   |          |    |    |
| Example 2                               | D5 - D2 - S3                    | D5        | 28                       | 9.08                     | D2         |                          |                          | 270      |          | S3        | 22                       | 20       | 17.92                    |   |          |    |    |

**TABLE NOTES:**

(1) Assembly Number Legend

Single Arm:  
Arm Type - Pole Type = D# - S#  
                                  = E# - T#  
                                  = F# - W#

Double Arm:  
First Arm Type - Second Arm Type - Pole Type = D# - D# - S#  
  = E# - E# - T#  
  = F# - F# - W#

(2) If an entry appears in columns "FAA" and "FBA", a shorter arm is required. This is obtained by removing length from the arm tip. For these cases the most arm length shall be shortened from "FA" to "FAA" and the tip diameter shall be increased from "FB" to "FBA".

(3) If an entry appears in columns "UAA" and "UCA", a shorter pole is required. This is obtained by removing length from the pole tip. For these cases the pole height shall be shortened from "UA" to "UAA" and the pole tip diameter shall be increased from "UC" to "UCA".

(4) The foundations for Standard Mast Arm Assemblies are pre-designed and are based upon the following conservative soil criteria which covers the great majority of soil types found in Florida. Only complete the "Special Drilled Shaft Data" information if site conditions dictate drilled shafts with additional foundation capacity.

Classification = Cohesionless (Fine Sand)  
Friction Angle = 30 Degrees (30°)  
Unit Weight = 50 lbs./cu.ft. (assumed saturated)

**EXAMPLE 1**

1. Select Arm Type.  
Investigate Arm F1. Compare attachment sizes and locations with design loading tree in **Figure 29.2 of Volume 1**. All signals and signs are no further from the pole than shown in the Arm F1 design loading tree. Select Arm Type F1.
2. Select Pole Type.  
Use Pole Selection Tables in **Index 17743** of the **Design Standards**. Select Pole Type W1.
3. Determine Arm Mounting Height.  
UB + 10' = 12.5' + 17.5' min. + 2'  
UB = 22' min. Use 22'

## EXAMPLE 2

1. Select First Arm Type.

Designate longest arm as First Arm. For 52' arm, investigate Arm D5. Compare attachment sizes and locations with design loading tree. All signals and signs are no larger than and are no further from the pole than shown in the Arm D5 design loading tree. Select Arm Type D5.

2. Specify shorter arm.

Enter 28' under FAA.

$$\text{FAA} + \text{FE} - \text{Splice} = 28' + 26' - 2' = 52'$$

Determine actual tip diameter.

$$\text{FBA} = \text{FB} + (60' - 52') \times \text{taper} = 7.96'' + 8' (0.14''/\text{ft}) = 9.08''$$

3. Select Second Arm Type.

Select Arm Type D2.

4. Enter angle between arms.

Angle UF is measured counter-clockwise from the First Arm and must be either 90° or 270°.

5. Select Pole Type.

Use Pole Selection Tables. Select Pole Type S3.

6. Determine Arm Mounting Height.

$$\text{UB} + 10' = 9.5' + 17.5' \text{min.} + 2'$$

$$\text{UB} = 19' \text{ min. Use } 20'$$

7. Specify shorter pole.

Enter 22' under UAA.

Determine actual tip diameter.

$$\text{UCA} = \text{UC} + (24' - 22') \times \text{taper} = 17.64'' + 2' (0.14''/\text{ft}) = 17.92''$$

## **24.8 Monotube Sheets**

Monotube assemblies require a special design. The Structures Design Engineer will provide all design details for a special design to be included in the plans. For a special design, place a note in the plans stating “Shop drawings will be required.”

**THIS PAGE LEFT BLANK INTENTIONALLY**





# Chapter 25

## Lighting Plans

### 25.1 General

Lighting Plans are usually a component set of plans. Projects with minor lighting may include these features on sheets in the roadway plan set or detailed on the roadway plans. When prepared as component plans they shall be assembled as a separate plans set complete with a key sheet, tabulation of quantities and all other relevant lighting sheets. When prepared as component plans, the sheets shall be numbered consecutively with the sheet numbers prefixed by the letter “L”.

The lighting plans shall show the construction details, electrical circuits, pole data, conduits, service points, luminaires, foundations, boring details and other relevant data.

A complete set of lighting plans shall include the following sheets:

1. Key Sheet
2. Tabulation of Quantities
3. Pole Data and Legend Sheet
4. Plan Sheets or Layout Sheets
5. Foundation Details - High Mast (if required)
6. Boring Data Sheets - High Mast (if required)

In addition, the lighting plans may contain sheets which were prepared separately (perhaps by a sub-consultant) and incorporated into the lighting plans early in the design process (prior to the establishment of sheet numbering). As an option, these may be identified with the following prefixes and placed at the end of the numbered sequence of the lighting plans:

GL-#      Soil Survey and Report of Core Borings normally associated with the lighting plans set

## 25.2 Key Sheet

The key sheet is the first sheet in the component plans set and shall be prepared as described in **Chapter 3**. The location map, length of project box and contract plans set information are not required on this sheet when shown on the lead key sheet. Index of lighting plans shall be shown on the left of the sheet. Other data, including name, consultant contract number, vendor number, and certificate of authorization number of the firm (when plans are prepared by a consultant), shall be shown as described in **Chapter 3**.

If shop drawings are anticipated, the name(s) and address(es) of the Delegated Engineer(s) for shop drawing review(s) shall be shown on the right side of the sheet.

## TABULATION OF QUANTITIES/PLANT SCHEDULE

| PAY ITEM NO. | PAYSIZE | SYM | BOTANICAL NAME                    | COMMON NAME             | INSTALLED SIZE        | MAX. MAINTAINED SIZE      | SPACING              | REMARKS  | UNIT | SHEET NUMBERS |       |        |       |        |       |        |       |         |       | TOTAL THIS SHEET |       | GRAND TOTAL |       |
|--------------|---------|-----|-----------------------------------|-------------------------|-----------------------|---------------------------|----------------------|--|------|---------------|-------|--------|-------|--------|-------|--------|-------|---------|-------|------------------|-------|-------------|-------|
|              |         |     |                                   |                         |                       |                           |                      |  |      | LD-5          |       | LD-6   |       | LD-7   |       | LD-8   |       | LD-9    |       | PLAN             | FINAL | PLAN        | FINAL |
|              |         |     |                                   |                         |                       |                           |                      |  |      | PLAN          | FINAL | PLAN   | FINAL | PLAN   | FINAL | PLAN   | FINAL | PLAN    | FINAL |                  |       |             |       |
| 570-1-2      |         | SOD | STENOTAPHRUM SECUNDATUM           | ST. AUGUSTINE GRASS     |                       |                           |                      | LAY SOLIDLY IN ALL INDICATED AREAS               | SY   | 330.78        |       | 140.89 |       | 346.11 |       | 493.44 | 44    | 5055.22 |       | 5055.22          |       |             |       |
| 580-1-1      | SMALL   | AG  | ARACHIS GLABRATA                  | PERENNIAL PEANUT        | 1 GAL.                | 6" HT.                    | 18" OC               | MOW REGULARLY TO PROMOTE FLOWERING               | EA   | 1655          |       | 1118   |       | 2729   |       | 0      | 334   | 5836    |       | 5836             |       |             |       |
|              | SMALL   | LEG | LIRIOPE MUSCARI "EVERGREEN GIANT" | EVERGREEN GIANT LIRIOPE | 1 GAL.                | 16" HT.                   | 24" OC               | THIN BY PLANT DIVISION EVERY 3-5 YEARS           | EA   | 434           |       | 381    |       | 0      | 805   | 0      | 1620  |         | 1620  |                  |       |             |       |
|              | SMALL   | AS  | ARISTIDA STRICTA                  | WIREGRASS               | 1 GAL.                | 2'-4" HT.<br>2'-3" SPREAD | 2' OC                | NO SERIOUS PESTS                                 | EA   | 465           |       | 513    |       | 0      | 0     | 0      | 978   |         | 978   |                  |       |             |       |
|              | SMALL   | IVD | ILEX VOMITORIA "SHELLINGS"        | DWARF YAUPON            | 3 GAL.                | 3'-4" HT.<br>3'-4" SPREAD | 3' OC                | 9 FEMALES TO 1 MALE/<br>MINIMAL PRUNING REQUIRED | EA   | 89            |       | 134    |       | 0      | 109   | 0      | 332   |         | 332   |                  |       |             |       |
|              | SMALL   | HF  | HERMERCALLIS FULVA                | DAYLILY                 | 1 GAL.                | 4' HT.                    | 24" OC               | THIN BY PLANT DIVISION EVERY 3-5 YEARS           | EA   | 131           |       | 288    |       | 530    | 0     | 0      | 949   |         | 949   |                  |       |             |       |
|              | SMALL   | TA  | TRACHELOSPERMUM ASIATICUM         | STAR JASMINE            | 1 QUART               | 2' HT.<br>4'-5" SPREAD    | 24" OC               | TRIM TO MAINTAIN BEDLINES                        | EA   | 0             |       | 753    |       | 431    | 0     | 383    | 1567  |         | 1567  |                  |       |             |       |
|              | SMALL   | CL  | COREOPSIS                         | COREOPSIS               | 1 GAL.                | 3' HT.                    | 24" OC               | REMOVE DEAD STEMS                                | EA   | 0             |       | 0      |       | 0      | 453   | 0      | 453   |         | 453   |                  |       |             |       |
|              | SMALL   | IV  | IRIS VIRGINICA                    | SOUTHERN BLUE FLAG IRIS | 1 GAL.                | 18" HT.                   | 12" OC               | THIN BY PLANT DIVISION EVERY 3-5 YEARS           | EA   | 0             |       | 0      |       | 0      | 461   | 0      | 461   |         | 461   |                  |       |             |       |
| 580-1-2      | LARGE   | QV  | QUERCUS VIRGINIANA                | LIVE OAK                | 14' HT.<br>65 GAL.    | 40' HT.                   | AS SHOWN<br>ON PLANS | 2" MINIMUM CALIPER/<br>MINIMAL PRUNING REQUIRED  | EA   | 7             |       | 1      |       | 0      | 9     | 0      | 17    |         | 17    |                  |       |             |       |
|              | LARGE   | VO  | VIBURNUM OBOVATUM                 | WALTER'S VIBURNUM       | 42" HT.<br>7 GAL      | 6' HT.                    | 48" OC               | PRUNE TO MAINTAIN NATURAL SHAPE                  | EA   | 181           |       | 183    |       | 0      | 57    | 0      | 424   |         | 424   |                  |       |             |       |
|              | LARGE   | LIS | LAGERSTROEMIA INDICA              | CREPE MYRTLE STANDARD   | 8'-10' HT.<br>30 GAL. | 20' HT.                   | AS SHOWN<br>ON PLANS | MULTI-TRUNK 3" MINIMUM CALIPER/" PER BRANCH      | EA   | 0             |       | 13     |       | 2      | 0     | 3      | 18    |         | 18    |                  |       |             |       |
|              | LARGE   | IOE | ILEX OPACA "EAST PALATKA"         | EAST PALATKA HOLLY      | 12' HT.<br>30 GAL.    | 25' HT.                   | AS SHOWN<br>ON PLANS | 9 FEMALES TO 1 MALE/<br>MINIMAL PRUNING REQUIRED | EA   | 0             |       | 3      |       | 0      | 0     | 0      | 3     |         | 3     |                  |       |             |       |
|              | LARGE   | TD  | TAXODIUM DISTICHUM                | BALD CYPRESS            | 8' HT.<br>30 GAL.     | 50' HT.                   | AS SHOWN<br>ON PLANS | 2" MINIMUM CALIPER/<br>MINIMAL PRUNING REQUIRED  | EA   | 0             |       | 0      |       | 0      | 3     | 0      | 3     |         | 3     |                  |       |             |       |
|              | LARGE   | BN  | BETULA NIGRA                      | RIVER BIRCH             | 12' HT.<br>30 GAL.    | 50' HT.                   | AS SHOWN<br>ON PLANS | 2" MINIMUM CALIPER/<br>WELL SHAPED               | EA   | 0             |       | 0      |       | 0      | 3     | 0      | 3     |         | 3     |                  |       |             |       |

Pay size in accordance with the Basis of Estimates Handbook

**Small plants Include:**

1. All ground covers
2. Shrubs to less than 7 gallon
3. Trees to less than 7 gallon
4. Palms clustering type less than 6 foot overall height
5. Cycads to less than 7 gallon

**Large plants Include:**

1. Shrubs 7 gallon or greater
2. Trees 7 gallon and greater
3. All palms single trunk
4. Palms clustering type 6 foot overall height and greater
5. Cycads 7 gallon or greater
6. All sabal palms (a.k.a. sabal palmetto, cabbage palm, state tree)

EXHIBIT: LD-1  
Date: 1/1/08

| REVISIONS |             |      |             | STATE OF FLORIDA<br>DEPARTMENT OF TRANSPORTATION |        |                      | <b>TABULATION OF QUANTITIES/<br/>PLANT SCHEDULE</b> | SHEET NO. |
|-----------|-------------|------|-------------|--|--------|----------------------|---|-----------|
| DATE      | DESCRIPTION | DATE | DESCRIPTION | ROAD NO.   | COUNTY | FINANCIAL PROJECT ID |   |           |
|           |             |      |             | 10   | LEON   | 123456-1-52-01       |   |           |



THIS EXHIBIT IS AN EXAMPLE NARRATIVE OF A STORMWATER POLLUTION PREVENTION PLAN (SWPPP) FOR A MAJOR RECONSTRUCTION PROJECT. ACTUAL PROJECT CONDITIONS OFTEN DICTATE DIFFERENT APPROACHES THAN SHOWN HERE. THE ENGINEER IS RESPONSIBLE FOR DEVELOPING A SITE SPECIFIC SWPPP THAT COMPLIES WITH VOLUME I CHAPTER 11 OF THE PLANS PREPARATION MANUAL.

THE FOLLOWING NARRATIVE OF THE STORMWATER POLLUTION PREVENTION PLAN CONTAINS REFERENCES TO THE STANDARD SPECIFICATIONS FOR ROAD AND BRIDGE CONSTRUCTION, THE DESIGN STANDARDS, AND OTHER SHEETS OF THESE CONSTRUCTION PLANS. THE FIRST SHEET OF THE CONSTRUCTION PLANS (CALLED THE KEY SHEET) CONTAINS AN INDEX TO THE OTHER SHEETS. THE COMPLETE STORMWATER POLLUTION PREVENTION PLAN INCLUDES SEVERAL ITEMS: THIS NARRATIVE DESCRIPTION, THE DOCUMENTS REFERENCED IN THIS NARRATIVE, THE CONTRACTOR'S APPROVED EROSION CONTROL PLAN REQUIRED BY SPECIFICATION SECTION 104, AND REPORTS OF INSPECTIONS MADE DURING CONSTRUCTION.

1.0 SITE DESCRIPTION:

1.A. NATURE OF CONSTRUCTION ACTIVITY:

THE PROJECT IS THE RECONSTRUCTION OF SR 007 (JAMES BOND BOULEVARD) TO A MAJOR URBAN ROADWAY. THIS INVOLVES CONSTRUCTING ROADWAY SURFACE, CURB AND GUTTER, SIDEWALK, UNDERGROUND STORM DRAIN SYSTEMS, AND STORMWATER MANAGEMENT FACILITIES. THE PROJECT EXTENDS FROM NORTH OF PAUL RUSSELL ROAD TO PERKINS STREET, A DISTANCE OF APPROXIMATELY 1.1 MILES.

1.B. SEQUENCE OF MAJOR SOIL DISTURBING ACTIVITIES:

IN THE SECTION 104 EROSION CONTROL PLAN, THE CONTRACTOR SHALL PROVIDE A DETAILED SEQUENCE OF CONSTRUCTION FOR ALL CONSTRUCTION ACTIVITIES. THE CONTRACTOR SHALL FOLLOW THE SEQUENCE OF MAJOR ACTIVITIES DESCRIBED BELOW, UNLESS THE CONTRACTOR PROPOSES A DIFFERENT SEQUENCE THAT IS EQUAL OR BETTER AT CONTROLLING EROSION AND TRAPPING SEDIMENT AND IS APPROVED BY THE ENGINEER.

FOR EACH CONSTRUCTION PHASE, INSTALL PERIMETER CONTROLS AFTER CLEARING AND GRUBBING NECESSARY FOR INSTALLATION OF CONTROLS BUT BEFORE BEGINNING OTHER WORK FOR THE CONSTRUCTION PHASE. REMOVE PERIMETER CONTROLS ONLY AFTER ALL UPSTREAM AREAS ARE STABILIZED.

1. CLEARING AND GRUBBING, EARTHWORK, AND STORM DRAIN CONSTRUCTION FOR THE OUTFALL FROM THE PONDS.
2. CLEARING AND GRUBBING, EARTHWORK FOR POND CONSTRUCTION.
3. STORM DRAIN AND ROADWAY UNDERDRAIN CONSTRUCTION. CONSTRUCT THE STORM DRAIN PIPE IN THE UPSTREAM DIRECTION.
4. EARTHWORK ASSOCIATED WITH THE CONSTRUCTION OF ROADWAY, GRAVITY WALL, CURB, SUBGRADE, BASE, PAVEMENT, AND SIDEWALK.
5. CONSTRUCT UNDERDRAIN IN POND BOTTOM.

1.C. AREA ESTIMATES:

TOTAL SITE AREA: 19.6 ACRES.  
TOTAL AREA TO BE DISTURBED: 19.6 ACRES.

1.D. RUNOFF DATA:

RUNOFF COEFFICIENTS:

BEFORE: 0.62  
DURING: VARIES FROM 0.62 TO 0.76  
AFTER: 0.76

SOILS DATA: THE RESULTS OF THE SOIL BORINGS ALONG THE ROADWAY ARE SHOWN IN THE ROADWAY SOIL SURVEY SHEET(S). THE RESULTS OF SOIL BORINGS DONE IN THE PONDS ARE SHOWN ON THE POND DETAIL SHEETS. THE NUMBERS FOR THESE ARE IDENTIFIED ON THE KEY SHEET OF THESE CONSTRUCTION PLANS. IN GENERAL, THE SOILS ARE CLAYEY SANDS.

OUTFALL INFORMATION:

THERE ARE 4 OUTFALLS.

\*1 DESCRIPTION: EXISTING POND AT LAURA LEE.

LOCATION: LATITUDE 30° 24' 30", LONGITUDE, 84° 16' 45".  
EST. DRAINAGE AREA SIZE: 13.6 ACRES.  
RECEIVING WATER NAME: NOT APPLICABLE.

\*2 DESCRIPTION: POND 1. THIS DISCHARGES TO THE STORM DRAIN SYSTEM THAT RUNS UNDER ORANGE AVENUE. THIS SYSTEM IN TURN DISCHARGES TO THE BOX CULVERT AT STA. 531+00.

LOCATION: LATITUDE 30° 24' 45", LONGITUDE 84° 17' 00".  
EST. DRAINAGE AREA SIZE: 7.3 ACRES.  
RECEIVING WATER NAME: EAST DITCH.

\*3 DESCRIPTION: BOX CULVERT AT STA. 531+00.

LOCATION: LATITUDE 30° 24' 45", LONGITUDE 84° 17' 00"  
EST. DRAINAGE AREA SIZE: 4.2 SQUARE MILES.  
RECEIVING WATER NAME: EAST DITCH.

\*4 DESCRIPTION: POND 2. THIS DISCHARGES TO THE SR 007 STORM DRAIN SYSTEM THAT DRAINS TO THE BOX CULVERT AT STA. 531+00.

LOCATION: LATITUDE 30° 25' 00", LONGITUDE 84° 17' 00".  
EST. DRAINAGE AREA SIZE: 15.4 ACRES.  
RECEIVING WATER NAME: EAST DITCH.

1.E. SITE MAP:

THE CONSTRUCTION PLANS ARE BEING USED AS THE SITE MAPS. THE LOCATION OF THE REQUIRED INFORMATION IS DESCRIBED BELOW. THE SHEET NUMBERS FOR THE PLAN SHEETS REFERENCED ARE IDENTIFIED ON THE KEY SHEET OF THESE CONSTRUCTION PLANS.

\* DRAINAGE PATTERNS: THE DRAINAGE BASIN DIVIDES AND FLOW DIRECTIONS ARE SHOWN ON THE DRAINAGE MAPS. THE BACK OF SIDEWALK PROFILE SHEETS SHOW OVERLAND FLOW DIRECTION AT THE RIGHT OF WAY LINE. THE ARROWS ABOVE AND BELOW THE PROFILE REPRESENT THE FLOW DIRECTION AT THE LEFT AND RIGHT PROPERTY LINE, RESPECTIVELY. ARROWS POINTING TO THE PROFILE INDICATE RUNOFF COMING TO THE SITE. POINTING AWAY FROM THE SITE INDICATE RUNOFF LEAVING THE SITE.

\* APPROXIMATE SLOPES: THE SLOPES OF THE SITE CAN BE SEEN IN THE CROSS SECTION SHEETS AND THE PLAN-PROFILE SHEETS. THERE ARE POND CROSS SECTIONS LOCATED WITH THE POND DETAIL SHEETS.

\* AREAS OF SOIL DISTURBANCE: THE AREAS TO BE DISTURBED ARE INDICATED ON THE PLAN-PROFILE SHEETS, THE CROSS SECTION SHEETS, AND THE POND DETAIL SHEETS. ANY AREAS WHERE PERMANENT FEATURES ARE SHOWN TO BE CONSTRUCTED ABOVE OR BELOW GROUND WILL BE DISTURBED.

\* AREAS NOT TO BE DISTURBED: ESSENTIALLY THE WHOLE PROJECT WILL BE DISTURBED DURING CONSTRUCTION.

\* LOCATIONS OF TEMPORARY CONTROLS: THESE ARE SHOWN ON THE EROSION CONTROL SHEETS EXCEPT FOR THE CONTROLS ASSOCIATED WITH THE BOX CULVERT REPLACEMENT WHICH ARE SHOWN ON THE BOX CULVERT CONSTRUCTION DETAIL SHEET. TABLES PROVIDING SUMMARIES OF TEMPORARY EROSION AND SEDIMENT CONTROL ITEMS ARE PROVIDED IN THE SUMMARY OF QUANTITY SHEETS.

\* LOCATIONS OF PERMANENT CONTROLS: THE STORMWATER PONDS ARE THE PRIMARY PERMANENT STORMWATER MANAGEMENT CONTROLS. THESE ARE SHOWN ON THE POND DETAIL SHEETS.

\* AREAS TO BE STABILIZED: TEMPORARY STABILIZATION PRACTICES ARE SHOWN IN THE SAME LOCATION AS THE TEMPORARY CONTROLS MENTIONED ABOVE. PERMANENT STABILIZATION IS SHOWN ON THE TYPICAL SECTION SHEETS, THE PLAN-PROFILE SHEETS AND THE POND DETAIL SHEETS.

\* SURFACE WATERS: THE ONLY SURFACE WATER WITHIN THE SITE IS THE EAST DITCH, WHICH FLOWS THROUGH THE CULVERT AT STATION 531+00. THIS IS LOCATED ON THE PLAN-PROFILE SHEETS AND THE BOX CULVERT CONSTRUCTION DETAIL SHEET.

\* DISCHARGE POINTS TO SURFACE WATERS: THERE IS ONLY ONE. THIS IS SHOWN ON THE PLAN-PROFILE SHEETS AT THE EAST DITCH (CULVERT AT STATION 531+00).

1.F. RECEIVING WATERS:

SEE ITEM 1.D FOR THE OUTFALL LOCATIONS AND RECEIVING WATER NAMES. THERE ARE NO WETLAND AREAS ON THE PROJECT SITE.

EXHIBIT SWP-1  
DATE: 1/1/08

| REVISIONS |             |      |             | STATE OF FLORIDA<br>DEPARTMENT OF TRANSPORTATION |        |                      | STORMWATER POLLUTION<br>PREVENTION PLAN | SHEET<br>NO. |
|-----------|-------------|------|-------------|--|--------|----------------------|---|--------------|
| DATE      | DESCRIPTION | DATE | DESCRIPTION | ROAD NO.   | COUNTY | FINANCIAL PROJECT ID |   |              |
|           |             |      |             | 7  | LEON   | 123456-1-52-01       |   |              |

#USERS

#DATES

#TIMES

#FILES

NOTICE: THE OFFICIAL RECORD OF THIS SHEET IS THE ELECTRONIC FILE SIGNED AND SEALED UNDER RULE 68G5-23.003, F.A.C.

THIS EXHIBIT IS AN EXAMPLE NARRATIVE OF A STORMWATER POLLUTION PREVENTION PLAN (SWPPP) FOR A MAJOR RECONSTRUCTION PROJECT. ACTUAL PROJECT CONDITIONS OFTEN DICTATE DIFFERENT APPROACHES THAN SHOWN HERE. THE ENGINEER IS RESPONSIBLE FOR DEVELOPING A SITE SPECIFIC SWPPP THAT COMPLIES WITH VOLUME I CHAPTER 11 OF THE PLANS PREPARATION MANUAL.

**2.0 CONTROLS:**

**2.A. EROSION AND SEDIMENT CONTROLS:**

IN THE SECTION 104 EROSION CONTROL PLAN, THE CONTRACTOR SHALL DESCRIBE THE PROPOSED STABILIZATION AND STRUCTURAL PRACTICES BASED ON THE CONTRACTOR'S PROPOSED TEMPORARY TRAFFIC CONTROL (TTC) PLAN. THE FOLLOWING RECOMMENDED GUIDELINES ARE BASED ON THE TEMPORARY TRAFFIC CONTROL PLAN OUTLINED IN THE CONSTRUCTION PLANS. WHERE FOLLOWING THE TEMPORARY TRAFFIC CONTROL PLAN OUTLINED IN THESE CONSTRUCTION PLANS, THE CONTRACTOR MAY CHOOSE TO ACCEPT THE FOLLOWING GUIDELINES OR MODIFY THEM IN THE SECTION 104 EROSION CONTROL PLAN, SUBJECT TO APPROVAL BY THE ENGINEER. AS WORK PROGRESSES, THE CONTRACTOR SHALL MODIFY THE PLAN TO ADAPT TO SEASONAL VARIATION, CHANGES IN CONSTRUCTION ACTIVITIES, AND THE NEED FOR BETTER PRACTICES.

FOR EACH CONSTRUCTION PHASE, INSTALL PERIMETER CONTROLS AFTER CLEARING AND GRUBBING NECESSARY FOR INSTALLATION OF CONTROLS BUT BEFORE BEGINNING OTHER WORK FOR THE CONSTRUCTION PHASE. REMOVE PERIMETER CONTROLS ONLY AFTER ALL UPSTREAM AREAS ARE STABILIZED.

**PHASE 1 OF TEMPORARY TRAFFIC CONTROL PLANS.**

**ROADWAY, STATION 501+10 TO 520+40 RIGHT:** IMMEDIATELY AFTER CONSTRUCTING THE TEMPORARY PAVEMENT, STABILIZE THE ENTIRE AREA BETWEEN THE TEMPORARY PAVEMENT AND THE RIGHT OF WAY LINE USING TEMPORARY SOD.

**OUTFALL OF POND 1:**

CONSTRUCT THE OUTFALL PIPE FROM S-106 TOWARDS THE POND. THE CONTRACTOR SHALL HAVE SANDBAGS AVAILABLE AT ALL TIMES DURING THE PIPE CONSTRUCTION TO SUBSTANTIALLY BLOCK RUNOFF IN THE TRENCH FROM ENTERING THE PIPE. CONSTRUCT PIPE TO THE POND AND CONSTRUCT THE OUTLET STRUCTURE OF THE POND.

**POND 1 CONSTRUCTION:**

CLEAR AND GRUB THE POND SITE. INITIALLY EXCAVATE THE POND ONLY ENOUGH TO CONSTRUCT TYPE IV SILT FENCE AS DETAILED IN THE TTC PLAN. THEN EXCAVATE THE POND TO APPROXIMATE PROPOSED DIMENSIONS. TURF ALL DISTURBED AREAS OF THE POND SITE ABOVE ELEVATION 51.0. FINAL GRADING WILL BE DONE AT THE END OF PHASE TWO OF THE TTC PLAN.

**ROADWAY, STATION 510+10 TO 523+70 LEFT:**

CONSTRUCT THE STORM DRAIN FROM THE POND TO THE ROADWAY AND THEN IN THE UPSTREAM DIRECTION ALONG THE LEFT SIDE OF THE PROJECT. DURING THE SUBSOIL EXCAVATION, AND CONSTRUCTION OF THE ROADWAY UNDERDRAIN, STORM DRAIN, AND WALL, USE S-19 AS THE PRIMARY INLET FOR CONVEYANCE TO THE POND. STAGE CONSTRUCT THE INLET AS DETAILED IN THE TTC PLAN.

**ROADWAY, STATION 501+10 TO 510+40 LEFT:**

DURING THE SUBSOIL EXCAVATION AND CONSTRUCTION OF THE UNDERDRAIN, STORM DRAIN, AND WALL, USE S-12 AS THE PRIMARY INLET FOR CONVEYANCE TO THE LAURA LEE POND. S-12 SHOULD BE CONSTRUCTED BEFORE DISTURBING SOIL UPSTREAM. STAGE CONSTRUCT AND PROTECT THE INLET AS DETAILED IN THE TTC PLAN.

**PHASE 11 OF THE TEMPORARY TRAFFIC CONTROL PLAN:**

**ROADWAY, STATION 510+10 TO 523+10 RIGHT:**

DURING THE SUBSOIL EXCAVATION AND CONSTRUCTION OF THE ROADWAY UNDERDRAIN AND STORM DRAIN, USE S-20 AS THE PRIMARY INLET FOR CONVEYANCE TO POND 1. STAGE CONSTRUCT AND PROTECT THE INLET IN A MANNER SIMILAR TO S-19 IN PHASE 1 OF THE TTC PLAN.

**ROADWAY, STATION 501+10 TO 510+40 RIGHT:**

DURING THE SUBSOIL EXCAVATION AND CONSTRUCTION OF THE UNDERDRAIN, STORM DRAIN, AND WALLS, USE S-10 AS THE PRIMARY INLET FOR CONVEYANCE TO THE LAURA LEE POND. STAGE CONSTRUCT AND PROTECT THE INLET IN A MANNER SIMILAR TO S-12 IN PHASE 1 OF THE TTC PLAN.

**POND 1 CONSTRUCTION:**

AFTER ENTIRE BASIN IS PERMANENTLY STABILIZED, CONSTRUCT UNDERDRAIN IN THE POND BOTTOM.

**2.A.1 STABILIZATION PRACTICES:**

IN THE SECTION 104 EROSION CONTROL PLAN, THE CONTRACTOR SHALL DESCRIBE THE STABILIZATION PRACTICES PROPOSED TO CONTROL EROSION. THE CONTRACTOR SHALL INITIATE ALL STABILIZATION MEASURES AS SOON AS PRACTICAL, BUT IN NO CASE MORE THAN 7 DAYS. IN PORTIONS OF THE SITE WHERE CONSTRUCTION ACTIVITIES HAVE TEMPORARILY OR PERMANENTLY CEASED, THE STABILIZATION PRACTICES SHALL INCLUDE AT LEAST THE FOLLOWING, UNLESS OTHERWISE APPROVED BY THE ENGINEER.

**TEMPORARY:**

- \* ARTIFICIAL COVERINGS IN ACCORDANCE WITH SPECIFICATION SECTION 104.
- \* TURF AND SOD IN ACCORDANCE WITH SPECIFICATION SECTION 104.

**PERMANENT:**

- \* ASPHALT OR CONCRETE SURFACE.
- \* SOD IN ACCORDANCE WITH SPECIFICATION SECTION 570.

**2.A.2 STRUCTURAL PRACTICES:**

IN THE SECTION 104 EROSION CONTROL PLAN, THE CONTRACTOR SHALL DESCRIBE THE PROPOSED STRUCTURAL PRACTICES TO CONTROL OR TRAP SEDIMENT AND OTHERWISE PREVENT THE DISCHARGE OF POLLUTANTS FROM EXPOSED AREAS OF THE SITE. SEDIMENT CONTROLS SHALL BE IN PLACE BEFORE DISTURBING SOIL UPSTREAM OF THE CONTROL. THE STRUCTURAL PRACTICES SHALL INCLUDE AT LEAST THE FOLLOWING, UNLESS OTHERWISE APPROVED BY THE ENGINEER:

**TEMPORARY:**

- \* SILT FENCE IN ACCORDANCE WITH DESIGN STANDARD 102 AND SPECIFICATION SECTION 104.
- \* SYNTHETIC BALES IN ACCORDANCE WITH DESIGN STANDARD 102 AND SPECIFICATION SECTION 104.
- \* SANDBAGS TO CONTROL EROSION AND TRAP SILT.
- \* INLET PROTECTION IN ACCORDANCE WITH DESIGN STANDARD 102 AND SPECIAL DETAILS SHOWN IN THE TTC PLAN.
- \* SEDIMENT BASIN. THE PERMANENT STORMWATER PONDS WILL BE TEMPORARILY MODIFIED ACCORDING TO THE DETAILS IN THE TTC PLAN.

**PERMANENT:**

- \* STORMWATER PONDS.
- \* SOD.

**2.B STORMWATER MANAGEMENT:**

SEVERAL STORM DRAIN SYSTEMS WILL BE CONSTRUCTED TO CONVEY RUNOFF TO THREE (3) STORMWATER RETENTION / DETENTION PONDS. THE FACILITIES HAVE BEEN PERMITTED BY THE FLORIDA DEPARTMENT OF ENVIRONMENTAL PROTECTION (FDEP) AND THE CITY OF NARCOOSSEE AND COMPLY WITH APPLICABLE DESIGN STANDARDS.

THE PARAGRAPH ABOVE REFERS TO A 7 DAY LIMIT BEFORE INITIATING STABILIZATION. THE DEP GENERIC PERMIT SPECIFIES 7 DAYS, BUT STRICTER REQUIREMENTS FROM OTHER PERMITTING AGENCIES WILL OFTEN APPLY AND SHOULD BE NOTED. FOR EXAMPLE, ST. JOHNS RIVER WATER MANAGEMENT DISTRICT HAS A 7 DAY LIMIT IN 40C-42 F.A.C.

EXHIBIT SWP-2  
DATE: 1/1/08

| REVISIONS |             |      |             | STATE OF FLORIDA<br>DEPARTMENT OF TRANSPORTATION |        |                      | STORMWATER POLLUTION<br>PREVENTION PLAN | SHEET<br>NO. |
|-----------|-------------|------|-------------|--|--------|----------------------|---|--------------|
| DATE      | DESCRIPTION | DATE | DESCRIPTION | ROAD NO.   | COUNTY | FINANCIAL PROJECT ID |   |              |
|           |             |      |             | 7  | LEON   | 123456-1-52-01       |   |              |

#USERS

#DATES

#TIMES

#FILES

NOTICE: THE OFFICIAL RECORD OF THIS SHEET IS THE ELECTRONIC FILE SIGNED AND SEALED UNDER RULE 6805-23.003, F.A.C.

THIS EXHIBIT IS AN EXAMPLE NARRATIVE OF A STORMWATER POLLUTION PREVENTION PLAN (SWPPP) FOR A MAJOR RECONSTRUCTION PROJECT. ACTUAL PROJECT CONDITIONS OFTEN DICTATE DIFFERENT APPROACHES THAN SHOWN HERE. THE ENGINEER IS RESPONSIBLE FOR DEVELOPING A SITE SPECIFIC SWPPP THAT COMPLIES WITH VOLUME I CHAPTER 11 OF THE PLANS PREPARATION MANUAL.

**2.C OTHER CONTROLS:**

**2.C.1 WASTE DISPOSAL:**

IN THE SECTION 104 EROSION CONTROL PLAN, THE CONTRACTOR SHALL DESCRIBE THE PROPOSED METHODS TO PREVENT THE DISCHARGE OF SOLID MATERIALS, INCLUDING BUILDING MATERIALS, TO WATERS OF THE UNITED STATES. THE PROPOSED METHODS SHALL INCLUDE AT LEAST THE FOLLOWING, UNLESS OTHERWISE APPROVED BY THE ENGINEER:

\* PROVIDING LITTER CONTROL AND COLLECTION WITHIN THE PROJECT DURING CONSTRUCTION ACTIVITIES.

\* DISPOSING OF ALL FERTILIZER OR OTHER CHEMICAL CONTAINERS ACCORDING TO EPA'S STANDARD PRACTICES AS DETAILED BY THE MANUFACTURER.

\* DISPOSING OF SOLID MATERIALS INCLUDING BUILDING AND CONSTRUCTION MATERIALS OFF THE PROJECT SITE BUT NOT IN SURFACE WATERS, OR WETLANDS.

**2.C.2 OFF-SITE VEHICLE TRACKING & DUST CONTROL:**

IN THE SECTION 104 EROSION CONTROL PLAN, THE CONTRACTOR SHALL DESCRIBE THE PROPOSED METHODS FOR MINIMIZING OFFSITE VEHICLE TRACKING OF SEDIMENTS AND GENERATING DUST. THE PROPOSED METHODS SHALL INCLUDE AT LEAST THE FOLLOWING, UNLESS OTHERWISE APPROVED BY THE ENGINEER.

\* COVERING LOADED HAUL TRUCKS WITH TARPAULINS.

\* REMOVING EXCESS DIRT FROM ROADS DAILY.

\* STABILIZING CONSTRUCTION ENTRANCES ACCORDING TO DESIGN STANDARD 106.

\* USING ROADWAY SWEEPERS DURING DUST GENERATING ACTIVITIES SUCH AS EXCAVATION AND MILLING OPERATIONS.

**2.C.3 STATE AND LOCAL REGULATIONS FOR WASTE DISPOSAL, SANITARY SEWER, OR SEPTIC TANK REGULATIONS:**

IN THE SECTION 104 EROSION CONTROL PLAN, THE CONTRACTOR SHALL DESCRIBE THE PROPOSED PROCEDURES TO COMPLY WITH APPLICABLE STATE AND LOCAL REGULATIONS FOR WASTE DISPOSAL, AND SANITARY SEWER OR SEPTIC SYSTEMS.

**2.C.4 FERTILIZERS AND PESTICIDES:**

IN THE SECTION 104 EROSION CONTROL PLAN, THE CONTRACTOR SHALL DESCRIBE THE PROCEDURES FOR APPLYING FERTILIZERS AND PESTICIDES. THE PROPOSED PROCEDURES SHALL COMPLY WITH APPLICABLE SUBSECTIONS OF SECTION 570 OF THE SPECIFICATIONS.

**2.C.5 TOXIC SUBSTANCES:**

IN THE SECTION 104 EROSION CONTROL PLAN, THE CONTRACTOR SHALL PROVIDE A LIST OF TOXIC SUBSTANCES THAT ARE LIKELY TO BE USED ON THE JOB AND PROVIDE A PLAN ADDRESSING THE GENERATION, APPLICATION, MIGRATION, STORAGE, AND DISPOSAL OF THESE SUBSTANCES.

**2.D.4 APPROVED STATE AND LOCAL PLANS AND PERMITS:**

\* FDEP RULE CHAPTER 62-25 F.A.C.

\* CITY OF MARCOOSSEE ENVIRONMENTAL MANAGEMENT ORDINANCE NUMBER 90-0-0044AA.

**3.0 MAINTENANCE:**

IN THE SECTION 104 EROSION CONTROL PLAN, THE CONTRACTOR SHALL PROVIDE A PLAN FOR MAINTAINING ALL EROSION AND SEDIMENT CONTROLS THROUGHOUT CONSTRUCTION. THE MAINTENANCE PLAN SHALL AT A MINIMUM, COMPLY WITH THE FOLLOWING:

\* SILT FENCE: MAINTAIN PER SECTION 104. THE CONTRACTOR SHOULD ANTICIPATE REPLACING SILT FENCE ON 12 MONTH INTERVALS.

\* SYNTHETIC BALES : REMOVE SEDIMENT WHEN IT REACHES 1/2 THE HEIGHT OF BALES OR WHEN WATER PONDS IN UNACCEPTABLE AMOUNTS OR AREAS.

\* PONDS ONE AND TWO: THE PONDS ARE TEMPORARY SEDIMENT BASINS UNTIL THE AREAS THAT DRAIN TO THEM ARE STABILIZED, SO UNTIL THEN, REMOVE SEDIMENT FROM THE POND WHEN IT BECOMES 1.5' DEEP AT ANY POINT.

**4.0 INSPECTIONS:**

QUALIFIED PERSONNEL SHALL INSPECT THE FOLLOWING ITEMS AT LEAST ONCE EVERY SEVEN CALENDAR DAYS AND WITHIN 24 HOURS OF THE END OF A STORM THAT IS 0.50 INCHES OR GREATER. TO COMPLY, THE CONTRACTOR SHALL INSTALL AND MAINTAIN RAIN GAUGES AND RECORD THE DAILY RAINFALL. WHERE SITES HAVE BEEN PERMANENTLY STABILIZED, INSPECTIONS SHALL BE CONDUCTED AT LEAST ONCE EVERY MONTH. THE CONTRACTOR SHALL ALSO INSPECT THAT CONTROLS INSTALLED IN THE FIELD AGREE WITH THE LATEST STORMWATER POLLUTION PREVENTION PLAN.

\* POINTS OF DISCHARGE TO WATERS OF THE UNITED STATES.

\* POINTS OF DISCHARGE TO MUNICIPAL SEPARATE STORM DRAIN SYSTEMS.

\* DISTURBED AREAS OF THE SITE THAT HAVE NOT BEEN FINALLY STABILIZED.

\* AREAS USED FOR STORAGE OF MATERIALS THAT ARE EXPOSED TO PRECIPITATION.

\* STRUCTURAL CONTROLS.

\* STORMWATER MANAGEMENT SYSTEMS.

\* LOCATIONS WHERE VEHICLES ENTER OR EXIT THE SITE.

THE CONTRACTOR SHALL INITIATE REPAIRS WITHIN 24 HOURS OF INSPECTIONS THAT INDICATE ITEMS ARE NOT IN GOOD WORKING ORDER.

IF INSPECTIONS INDICATE THAT THE INSTALLED STABILIZATION AND STRUCTURAL PRACTICES ARE NOT SUFFICIENT TO MINIMIZE EROSION, RETAIN SEDIMENT, AND PREVENT DISCHARGING POLLUTANTS, THE CONTRACTOR SHALL PROVIDE ADDITIONAL MEASURES, AS APPROVED BY THE ENGINEER.

**5.0 NON-STORMWATER DISCHARGES:**

IN THE SECTION 104 EROSION CONTROL PLAN, THE CONTRACTOR SHALL IDENTIFY ALL ANTICIPATED NON-STORMWATER DISCHARGES (EXCEPT FLOWS FROM FIRE FIGHTING ACTIVITIES). THE CONTRACTOR SHALL DESCRIBE THE PROPOSED MEASURES TO PREVENT POLLUTION OF THESE NON-STORMWATER DISCHARGES. IF THE CONTRACTOR ENCOUNTERS CONTAMINATED SOIL OR GROUNDWATER, CONTACT DAVE LETTERMAN, DISTRICT HAZARDOUS MATERIALS COORDINATOR AT (305) 63B-R549.

EXHIBIT SWP-3  
DATE: 1/1/08

| REVISIONS |             |      |             | STATE OF FLORIDA<br>DEPARTMENT OF TRANSPORTATION |        |                      | STORMWATER POLLUTION<br>PREVENTION PLAN | SHEET<br>NO. |
|-----------|-------------|------|-------------|--|--------|----------------------|---|--------------|
| DATE      | DESCRIPTION | DATE | DESCRIPTION | ROAD NO.   | COUNTY | FINANCIAL PROJECT ID |   |              |
|           |             |      |             | 7  | LEON   | 123456-1-52-01       |   |              |

#USERS #DATES #TIMES #FILES

NOTICE: THE OFFICIAL RECORD OF THIS SHEET IS THE ELECTRONIC FILE SIGNED AND SEALED UNDER RULE 68G5-23.003, F.A.C.

