

GENERAL NOTES:

1. Provide flared end sections meeting the requirements of ASTM C76 with the exception that dimensions and reinforcement meet the criteria in the table on sheet 2. Circumferential reinforcement may consist of either one cage or two cages of steel. Use concrete compressive strength of 4000 psi.
2. Connections between the flared end section and the pipe culvert may be any of the following types unless otherwise shown on the plans.
 - a. Joints meeting the requirements of Section 449 of the Standard Specifications (O-Ring Gasket). Flared end section joint dimensions and tolerances shall be identical or compatible to those used in the pipe culvert joint. When pipe culvert and flared end section manufacturers are different, the manufacturer of the flared end sections must certify the compatibility of joint designs.
 - b. Joints sealed with preformed plastic gaskets. Use gaskets that meet the requirements Specification 942-2 of the Standard Specifications and the minimum sizes for gaskets as specified for equivalent sizes of elliptical pipe.
 - c. Reinforced concrete jackets, as detailed on sheet 2. When non-coated corrugated metal pipe is called for in the Plans, use bituminous coated pipe in the jacketed area as specified on Index 430-001. Construct concrete jacket as specified in Index 430-001.
3. Cast Toe Walls in place using Class II Concrete.
4. On skewed pipe culverts place the flared end sections in line with the pipe culvert. Warp the side slopes as required to fit the flared end sections.
5. Quantities shown are for estimating purposes only.

TABLE OF CONTENTS:	
Sheet	Description
1	General Notes and Contents
2	Straight Flare, Optional Shape Details, and Reinforced Concrete Jacket Detail

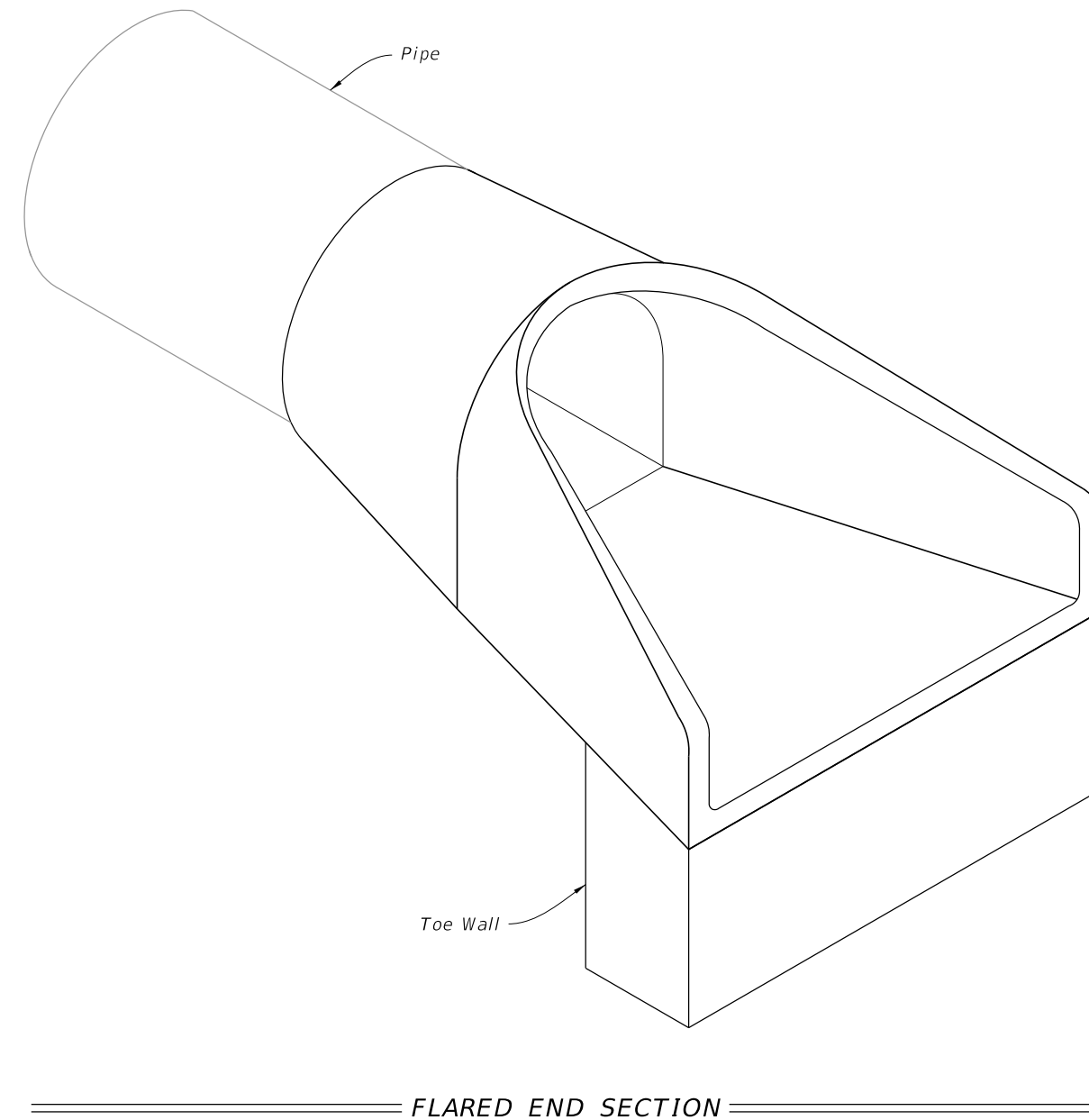

9/26/2025 12:59:22 PM

Pipe Dia.	T	Reinf. sq. in. Per Foot	Bell or Spigot	A	B	C	D	E	P	R 1	R 2	FLAT	h	Toe Wall Class II Conc. (CY.)
12"	2"	0.07	1½"	4"	2'-0"	4'-0⅞"	6'-0⅞"	2'-0"	19½⅞"	10½"	9"	3½"	12"	.06
15"	2¼"	0.07	2"	6"	2'-3"	3'-10"	6'-1"	2'-6"	24¾⅞"	12½"	11"	3½"	12"	.07
18"	2½"	0.07	2½"	9"	2'-3"	3'-10"	6'-1"	3'-0"	29"	15½"	12"	4"	15"	.11
21"	2¾"	0.07	2¼"	9"	2'-11"	3'-2"	6'-1"	3'-6"	31¾⅞"	16½"	13"	4"	15"	.12
24"	3"	0.07	2½"	9½"	3'-7½"	2'-6"	6'-1½"	4'-0"	33¾⅞"	16¾⅞"	14"	4½"	18"	.17
27"	3¼"	0.148	2½"	10½"	4'-0"	2'-1½"	6'-1½"	4'-6"	36"	18½"	14½"	4½"	18"	.19
30"	3½"	0.148	3"	1'-0"	4'-6"	1'-7¾"	6'-1¾"	5'-0"	37"	18½"	15"	5"	21"	.24
36"	4"	0.148	3½"	1'-3"	5'-3"	2'-10¾"	8'-1¾"	6'-0"	47¼⅞"	24¾⅞"	20"	5½"	21"	.29
42"	4½"	0.148	3¾"	1'-9"	5'-3"	2'-11"	8'-2"	6'-6"	53⅞"	27½"	22"	5½"	24"	.36
48"	5"	0.148	4¼"	2'-0"	6'-0"	2'-2"	8'-2"	7'-0"	56½"	28½"	22"	5¾"	24"	.39
54"	5½"	0.174	4¾"	2'-3"	5'-5"	2'-11"	8'-4"	7'-6"	65½"	33⅞"	24"	6¼"	24"	.42
60"	6"	0.174	5"	2'-6"	5'-0"	3'-3"	8'-3"	8'-0"	72½"	36¼⅞"	24"	6¾"	24"	.44
66"	6½"	0.174	5½"	2'-0"	6'-6"	1'-9"	8'-3"	8'-6"	72"	36⅞"	24"	7¼"	24"	.47
72"	7"	0.174	6"	2'-0"	6'-6"	1'-9"	8'-3"	9'-0"	77¼⅞"	38¾⅞"	24"	7¾"	24"	.50

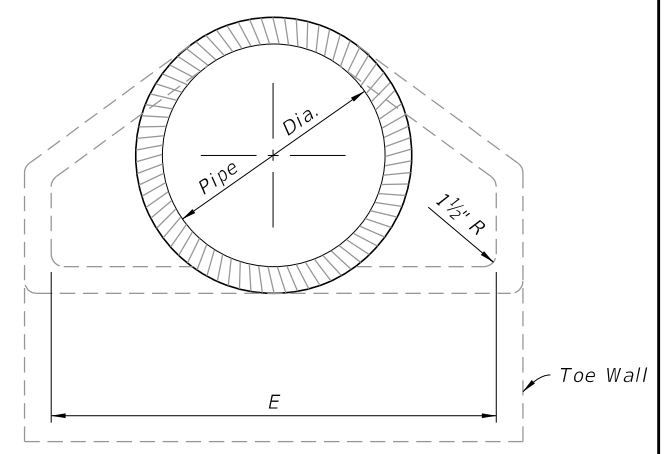
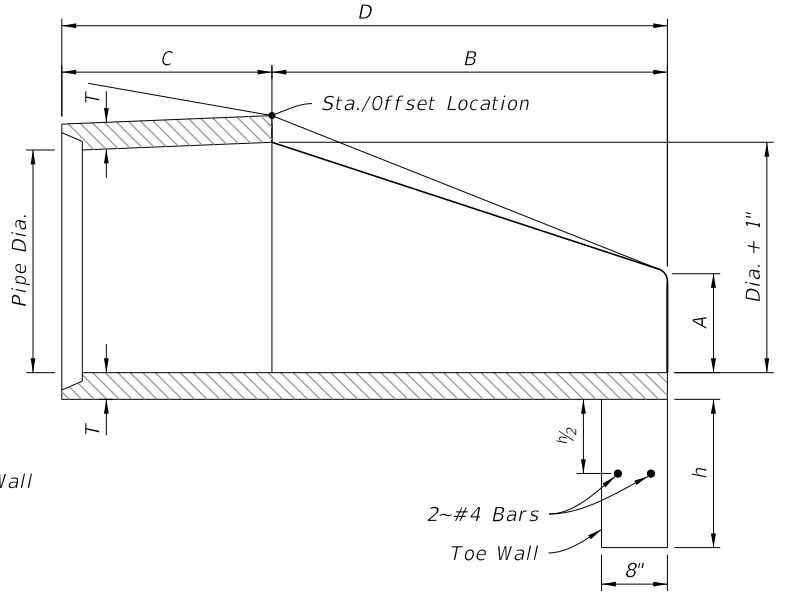
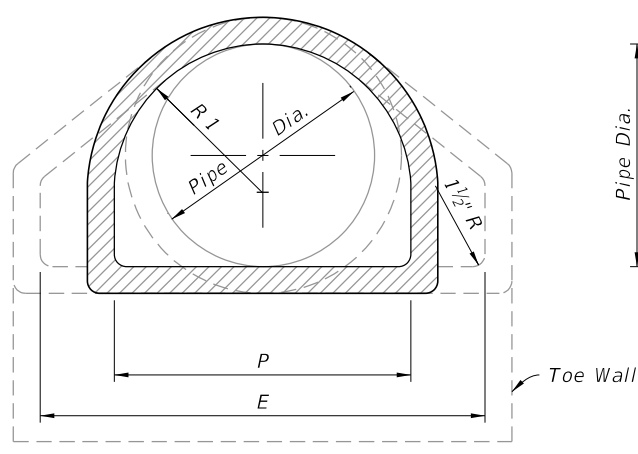
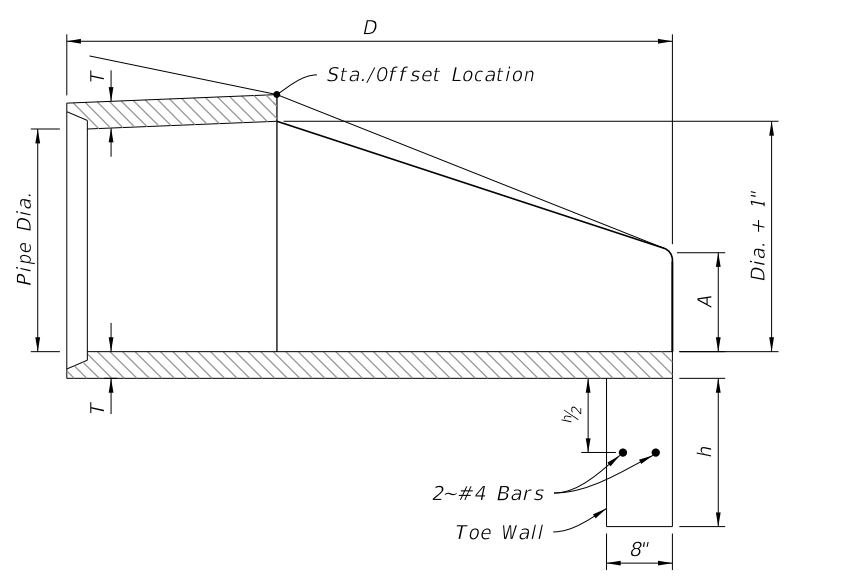
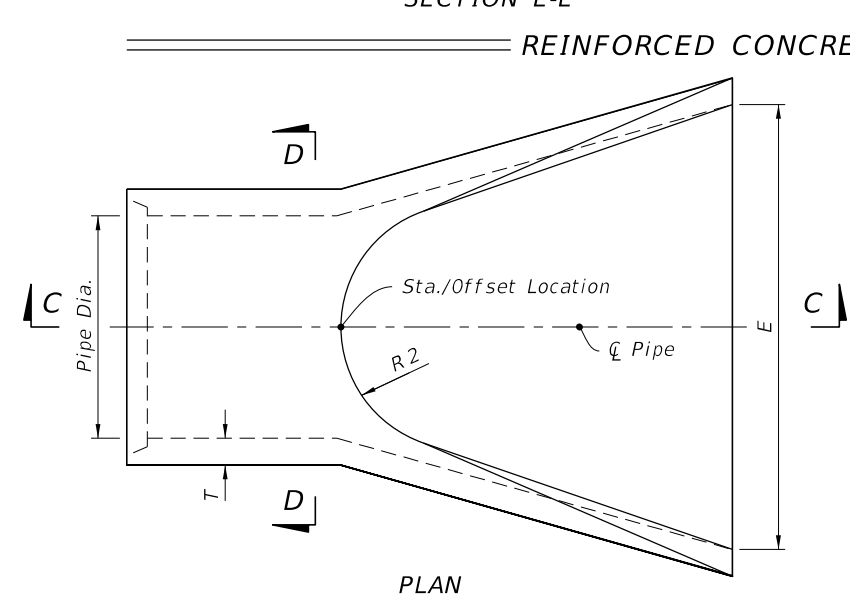
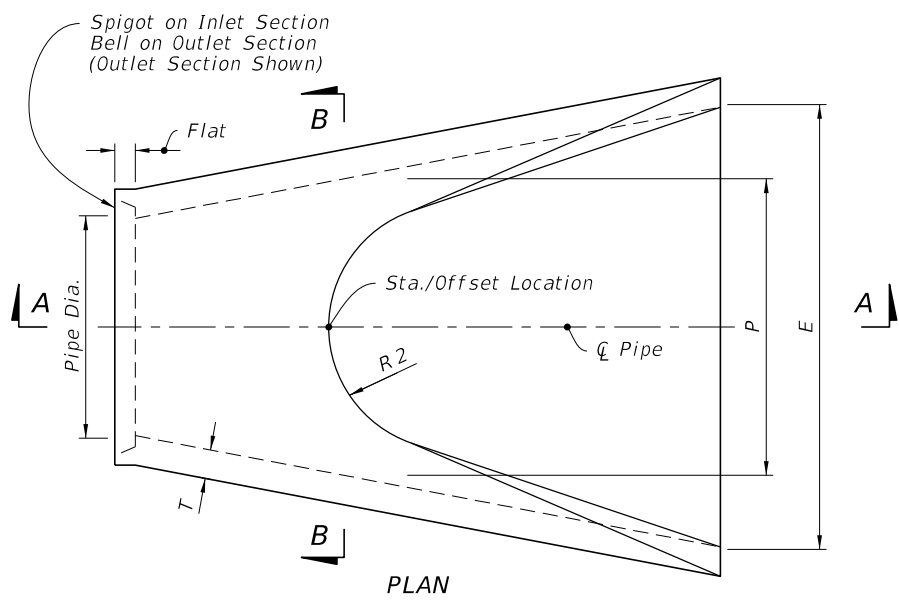
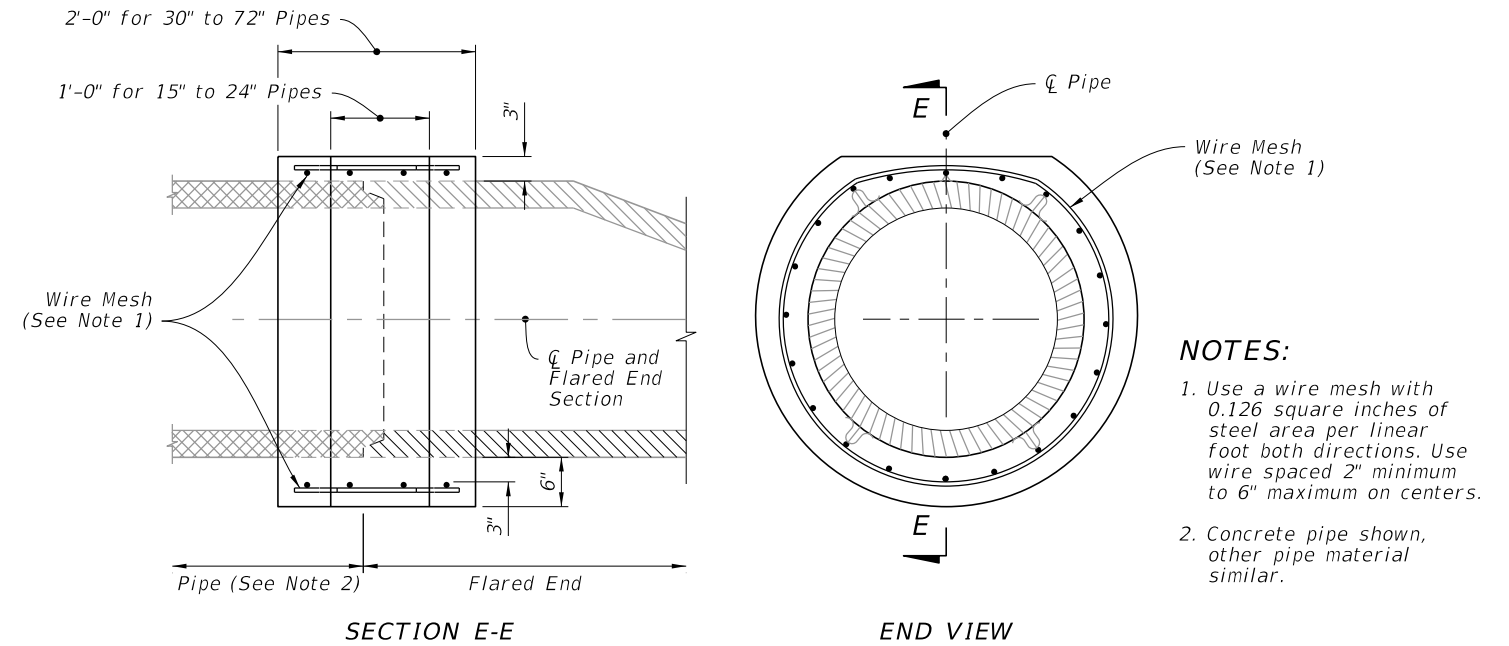

STRAIGHT FLARE

OPTIONAL SHAPE

10/14/2025 10:56:28 AM