

\* The 45" Ø Void in the pile shall be positively vented to water or air after the final pile installation. If the 3 1/2" Ø vents are included in the pile cut-off section, then venting shall be provided by the use of a 1" Ø PVC conduit through the substructure cap or column. Adjust spiral reinforcing as necessary to accommodate the 3 1/2" Ø vent.

**ELEVATION**

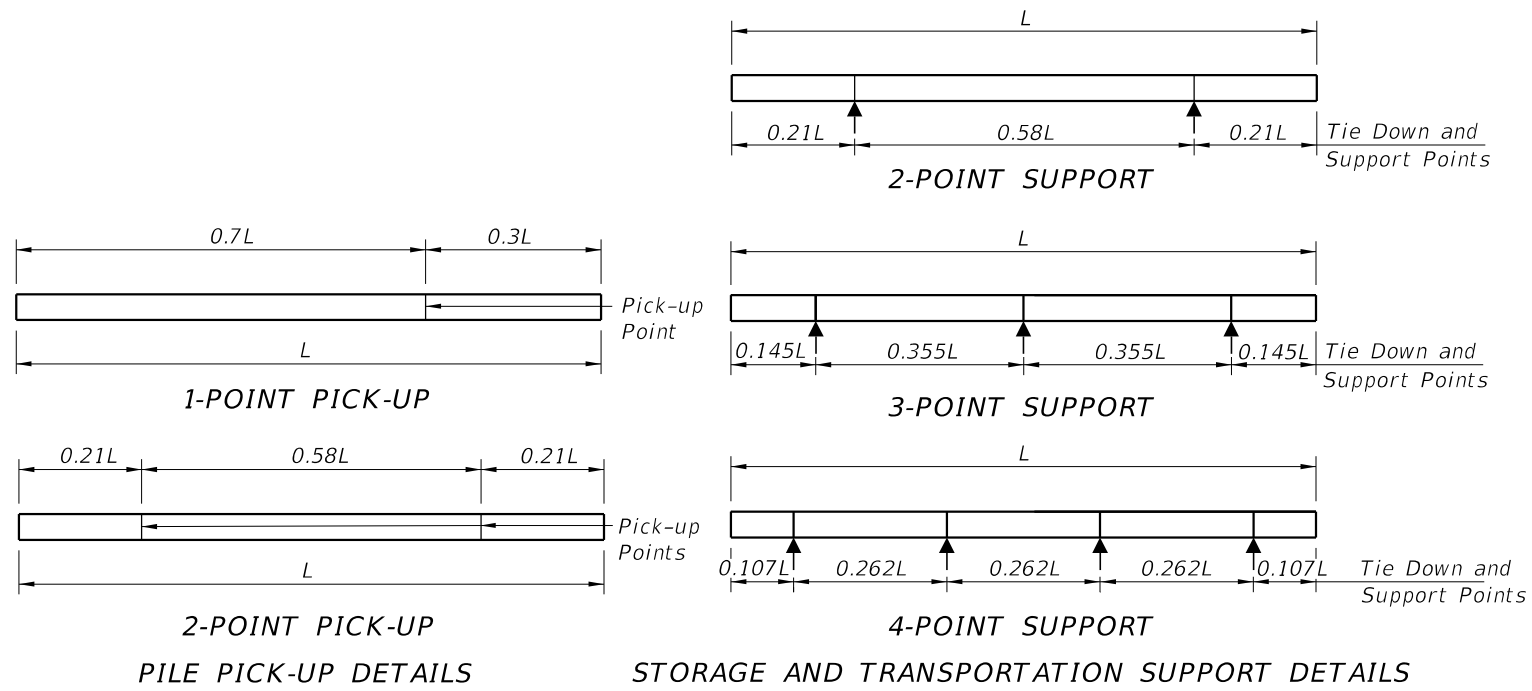

**NOTES**

1. Work this Index with the Pile Data Table in the Structures Plans.
2. Concrete:
  - A. Piles: Class V
  - B. Splice Collar: Class IV
  - C. See "GENERAL NOTES" in the Structures Plans for locations where the use of Highly Reactive Pozzolans is required.
3. Concrete Strength at time of prestress transfer:
  - A. Piles: 4,000 psi minimum.
4. Carbon-Steel Reinforcing:
  - A. Bars: Meet the requirements of Specification Section 415
  - B. Prestressing Strands: Use 0.6 dia. carbon-steel, Grade 270, low-relaxation strand stressed to 44.0 kips that meets the requirements of Specification Section 933.
  - C. Protect all carbon-steel strands permanently exposed to the environment and not embedded under final conditions in accordance with Specification Section 450.
5. Spiral Ties:
  - A. One half turn is required for carbon-steel spiral splices
  - B. One full turn is required at the head and tip of each pile
6. Pile Splices:
  - A. Epoxy: Type AB Epoxy Compound or Epoxy Mortar must meet the requirements of Specification Section 926.
    - a. Use a Type AB Epoxy Bonding Compound or Epoxy Mortar, as recommended by the Manufacturer, to form the joint between pile sections.
    - b. Use a Type AB Epoxy Bonding Compound as a bonding agent on internal pile surfaces.
  - B. Splices: Resume pile driving after the splice concrete reaches a minimum strength of 5,500 psi.
7. Mark piles at the pick-up points to indicate the proper points for attaching handling lines.

TABLE OF MAXIMUM PILE PICK-UP AND SUPPORT LENGTHS		
Maximum Pile Length (Feet)	Required Storage and Transportation Detail	Pick-Up Detail
122	2, 3, or 4 point	1 Point
174	2, 3, or 4 point	2 Point

10/22/2025 11:50:34 AM

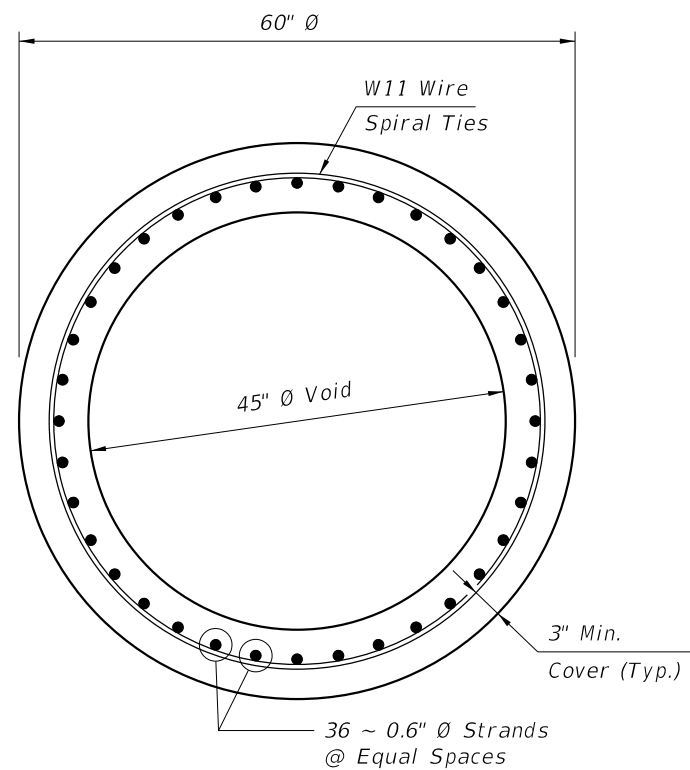
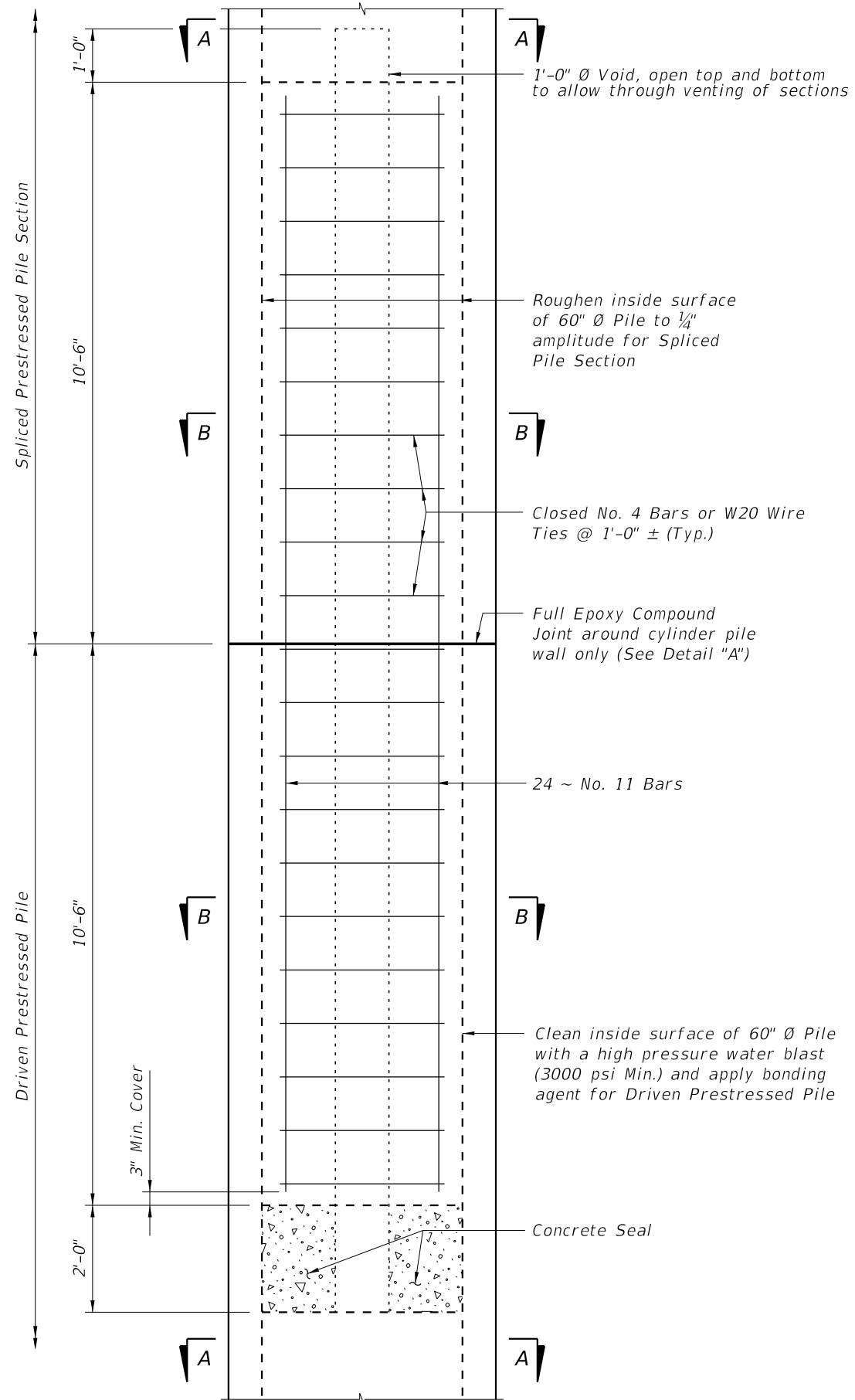

SECTION A-A

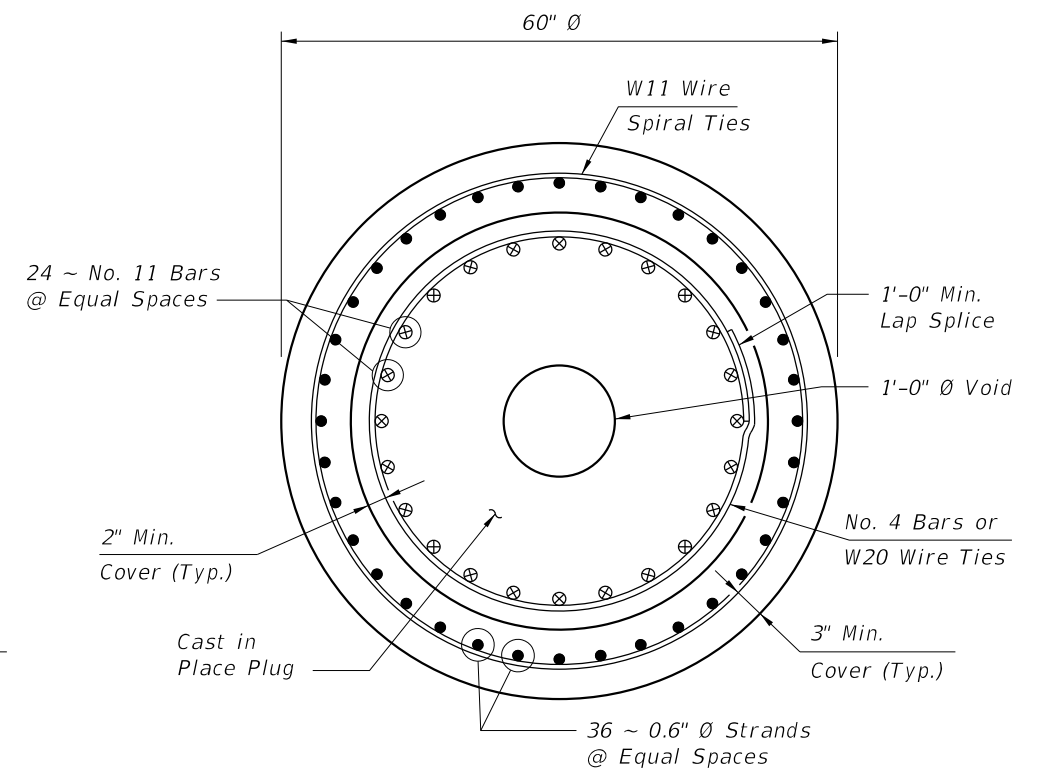

SECTION B-B

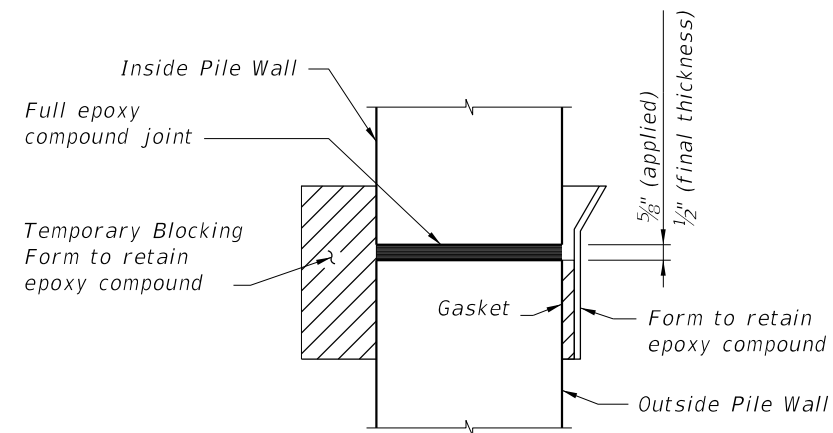

DETAIL "A"

DRIVABLE UNFORESEEN FIELD SPLICE DETAIL  
(Cast in Place Plug)

10/6/2025 2:49:07 PM

LAST REVISION 01/01/12	DESCRIPTION:		FY 2026-27 STANDARD PLANS	60" PRESTRESSED CONCRETE CYLINDER PILE	INDEX	SHEET
					455-060	2 of 2