

*The 45" Ø Void in the pile shall be positively vented to water or air after the final pile installation. If the 3½" Ø vents are included in the pile cut-off section, then venting shall be provided by the use of a 1" Ø PVC conduit through the substructure cap or column.

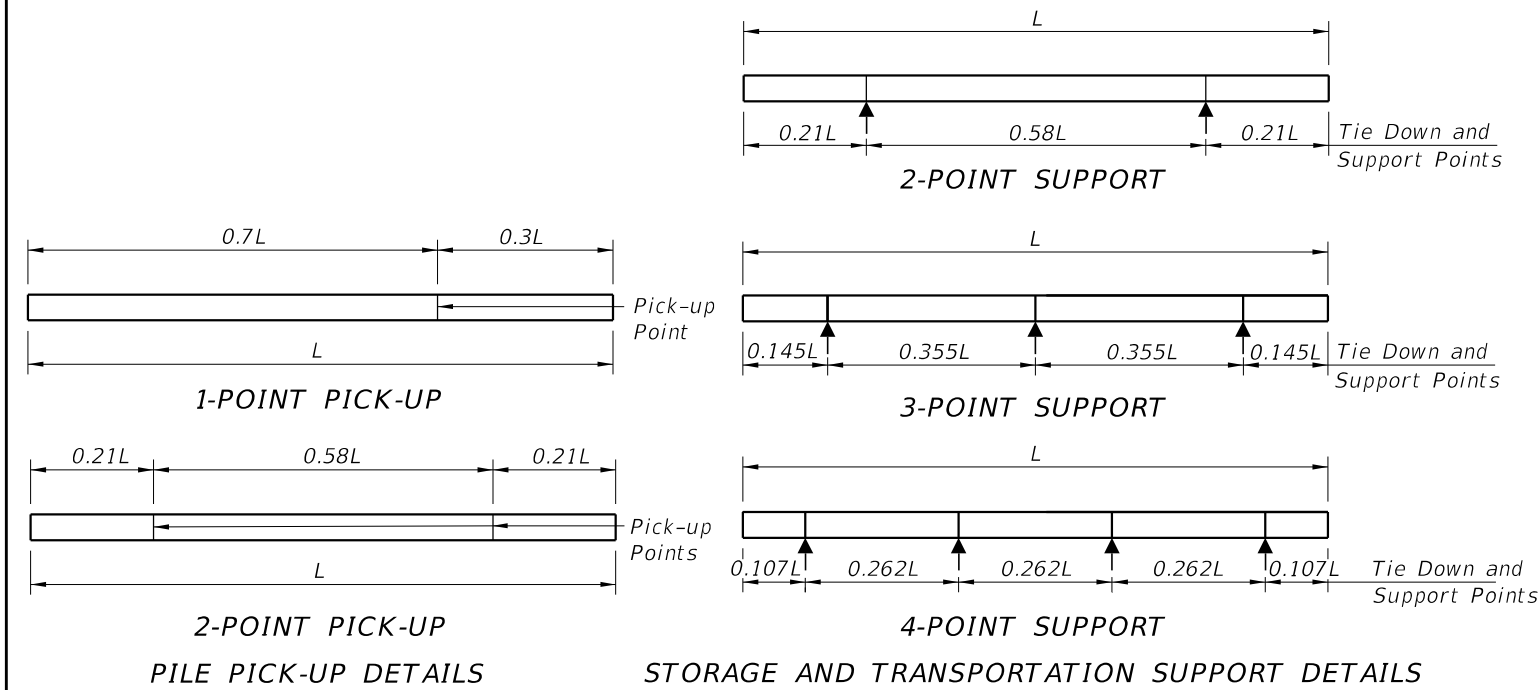
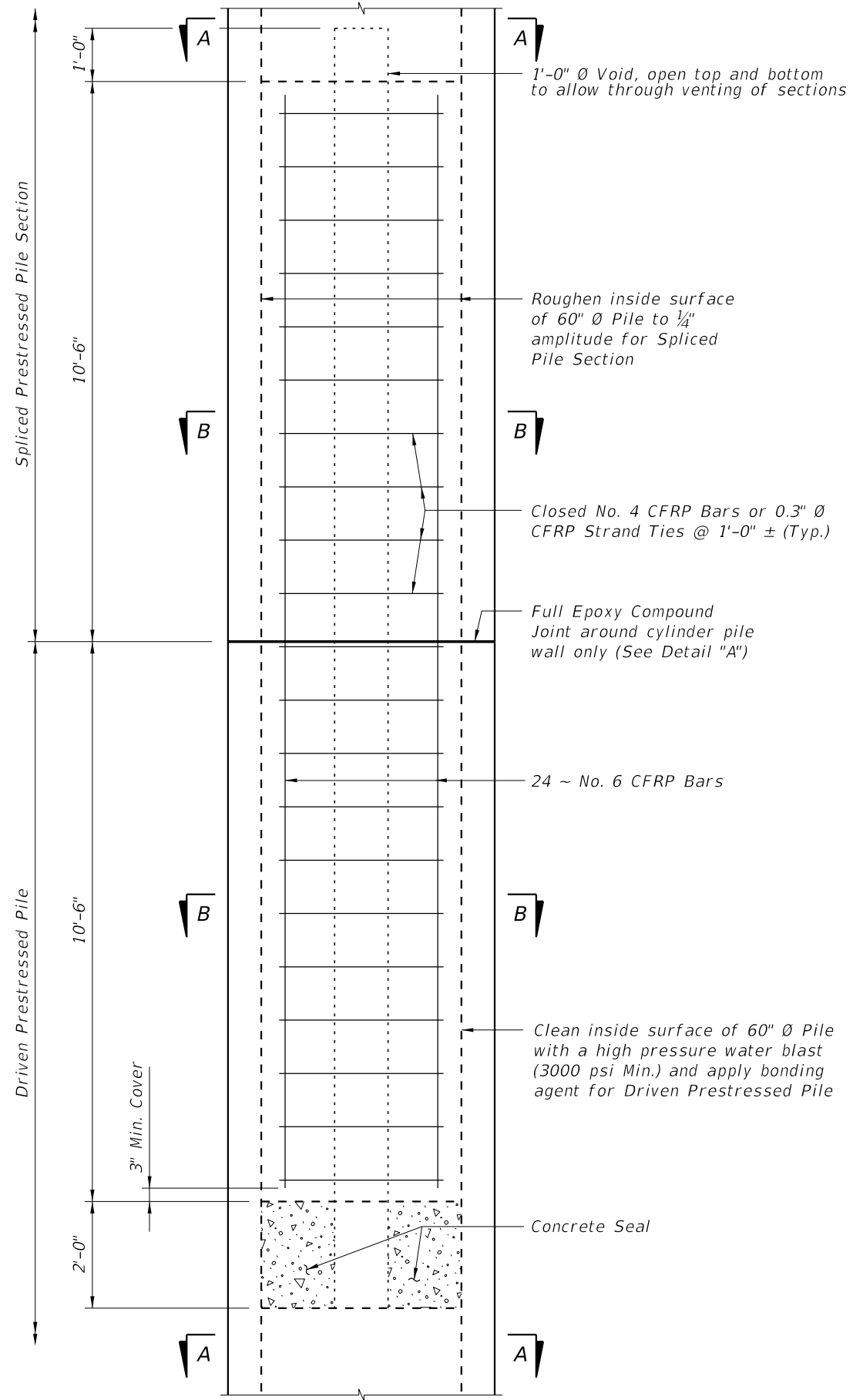

TABLE OF MAXIMUM PILE PICK-UP AND SUPPORT LENGTHS		
Maximum Pile Length (Feet)	Required Storage and Transportation Detail	Pick-Up Detail
122	2, 3, or 4 point	1 Point
174	2, 3, or 4 point	2 Point

NOTES

- Work this Index with the Pile Data Table in the Structures Plans.
- Concrete:
 - Piles: Class V
 - Splice Collar: Class IV
 - See "GENERAL NOTES" in the Structures Plans for locations where the use of Highly Reactive Pozzolans is required.
- Concrete Strength at time of prestress transfer:
 - Piles: 4,000 psi minimum.
- Reinforcing:
 - Bars:
 - Stainless Steel: Meet the requirements of Specification Section 931 for Type 304, Grade 75.
 - Carbon FRP: Meet the requirements of Specification Section 932.
 - Prestressing Strands:
 - Stainless Steel: Seven-wire HSSS, UNS S32205 (Type 2205) or UNS S31803 strand, meeting the requirements of Specification Section 933.
 - Carbon FRP: Meet the requirements of Specification Section 933.
 - Spiral Ties:
 - One half turn is required for carbon steel spiral splice.
 - One full turn is required at the pile head and tip.
- Pile Splices:
 - Epoxy: Type AB Epoxy Compound or Epoxy Mortar must meet the requirements of Specification Section 926.
 - Use a Type AB Epoxy Bonding Compound or Epoxy Mortar, as recommended by the Manufacturer, to form the joint between pile sections
 - Use a Type AB Epoxy Bonding Compound as a bonding agent on internal pile surfaces.
 - Splices: Resume pile driving after the splice concrete reaches a minimum strength of 5,500 psi.
- Mark piles at the pick-up points to indicate the proper points for attaching handling lines.

10/6/2025 2:53:40 PM



DRIVABLE UNFORESEEN FIELD SPLICE DETAIL
(Cast in Place Plug)

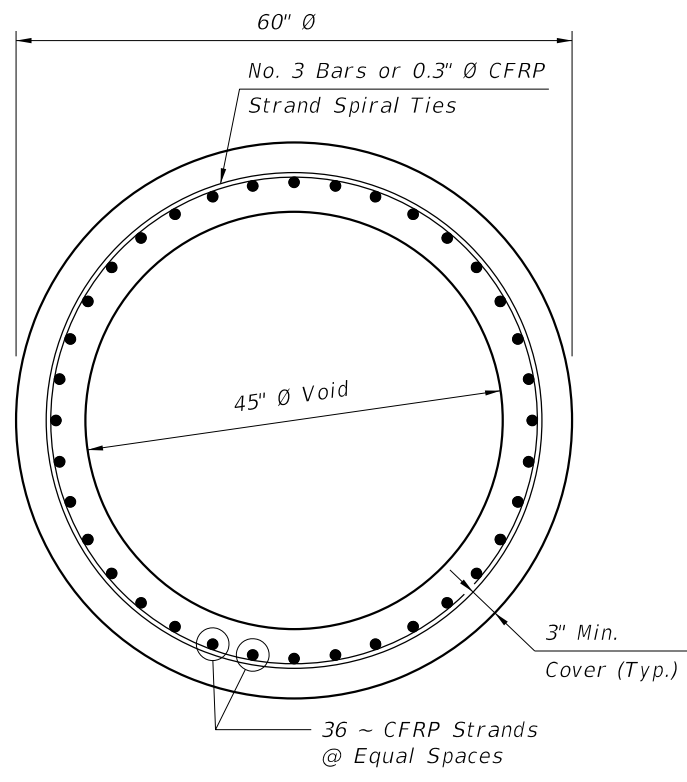

SECTION A-A

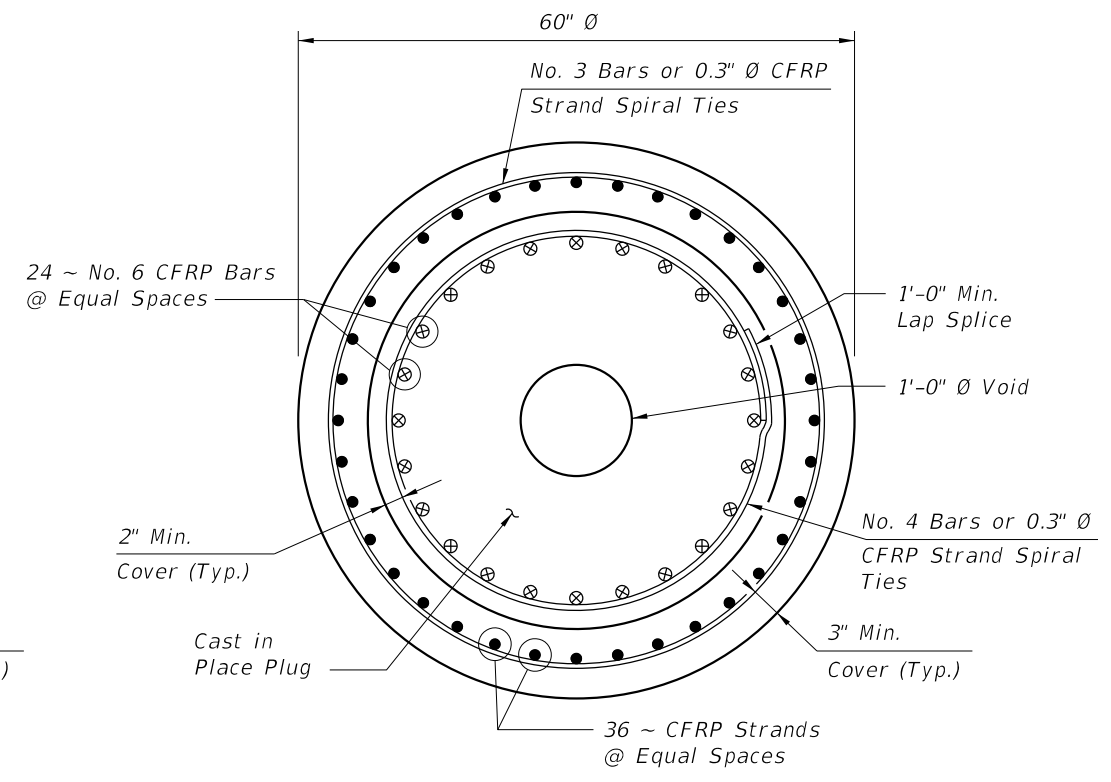

SECTION B-B

ALTERNATE STRAND PATTERNS

- 0.5" Ø, CFRP Single-Strand, at 39 kips
- 0.6" Ø, CFRP 7-Strand, at 40 kips

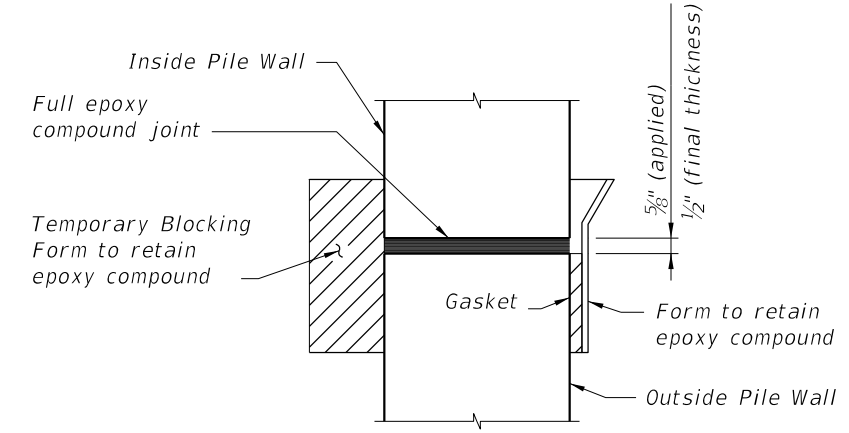

DETAIL "A"

10/6/2025 2:53:46 PM

LAST REVISION 01/01/16	DESCRIPTION:	FY 2026-27 STANDARD PLANS	60" PRESTRESSED CFRP & SS CONCRETE CYLINDER PILE	INDEX 455-160	SHEET 2 of 3
---------------------------	--------------	--------------------------------------	---	------------------	-----------------

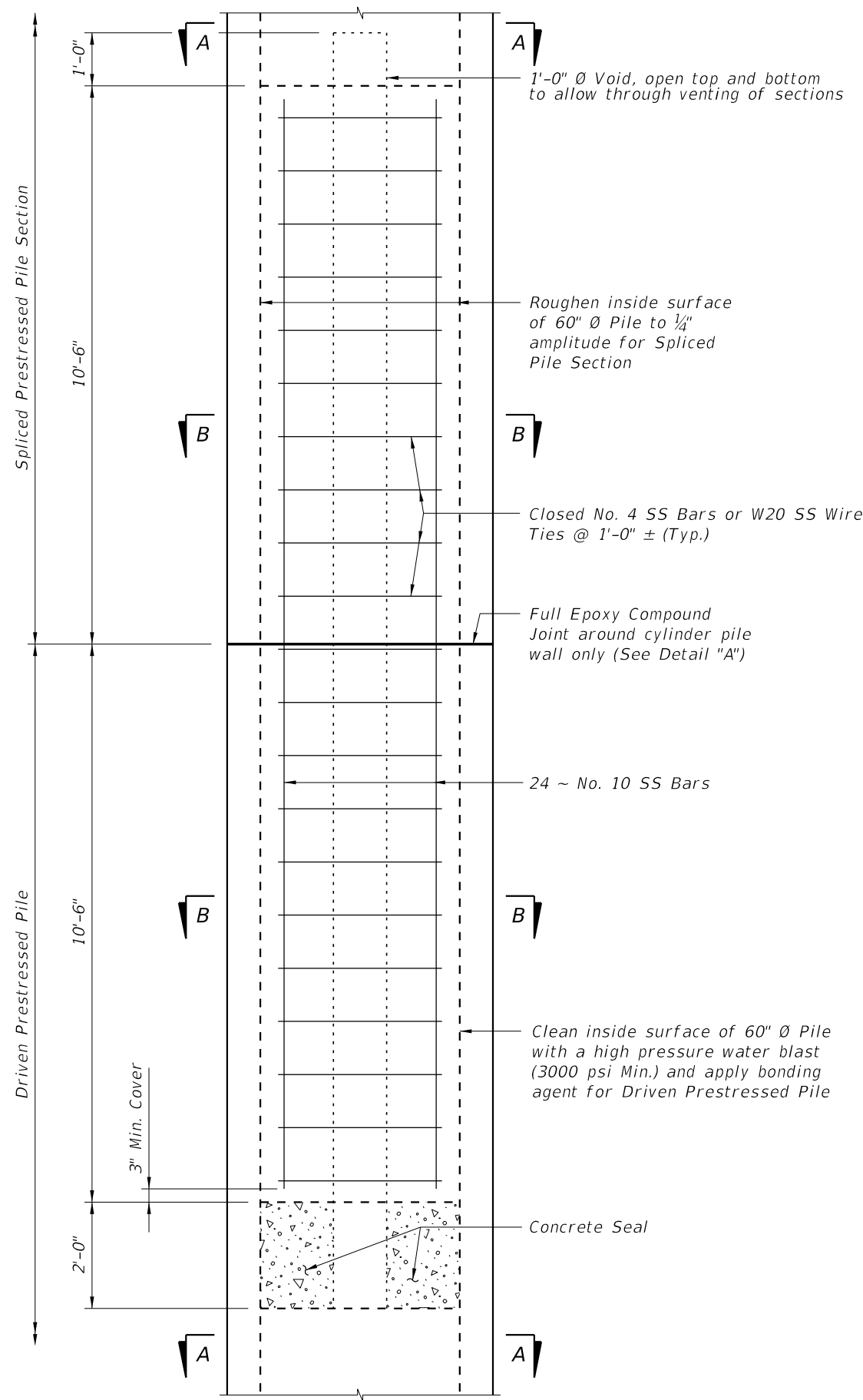

DRIVABLE UNFORESEEN FIELD SPLICE DETAIL
(Cast in Place Plug)

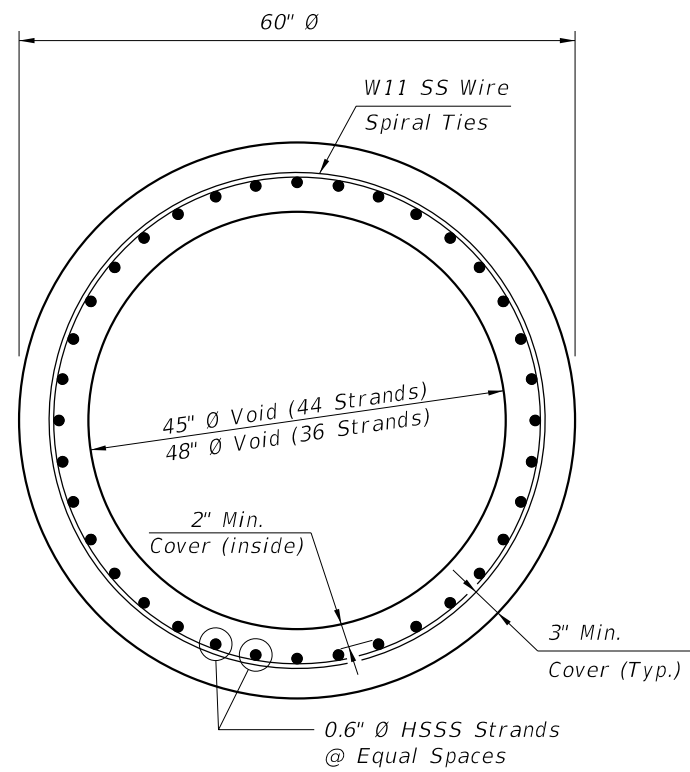

SECTION A-A

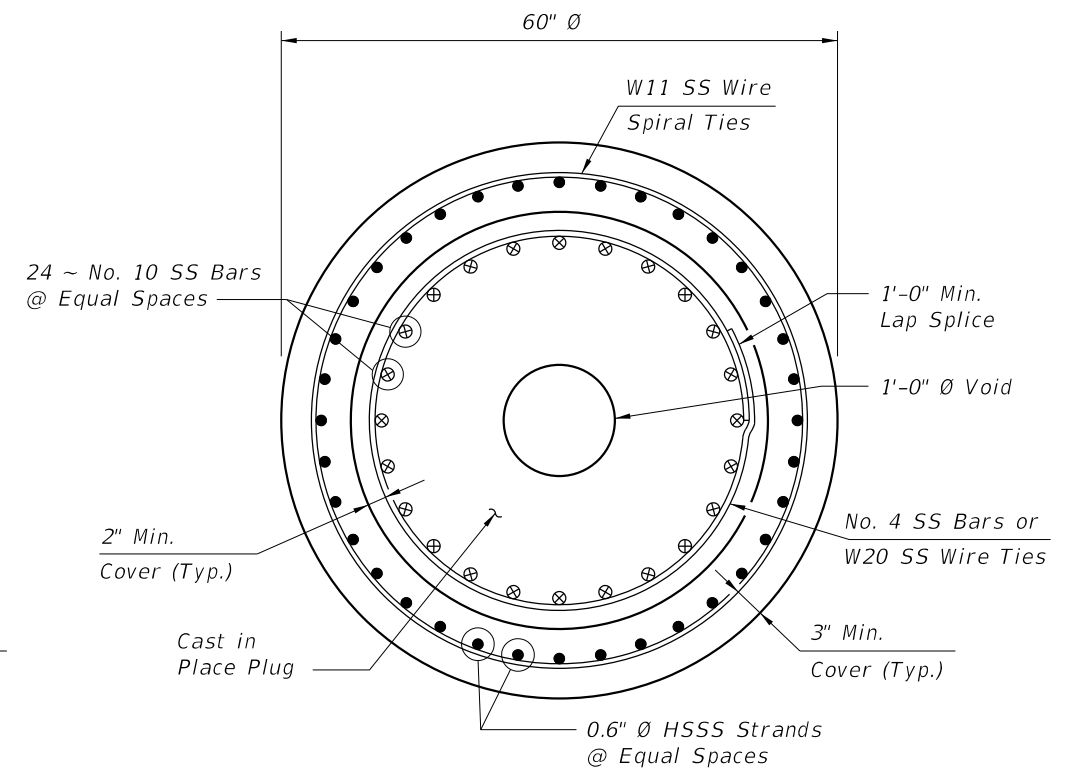

SECTION B-B

ALTERNATE STRAND PATTERNS

- 44 ~ 0.6" Ø, HSSS Strand, at 36 kips
- 36 ~ 0.6" Ø, HSSS Strand, at 36 kips

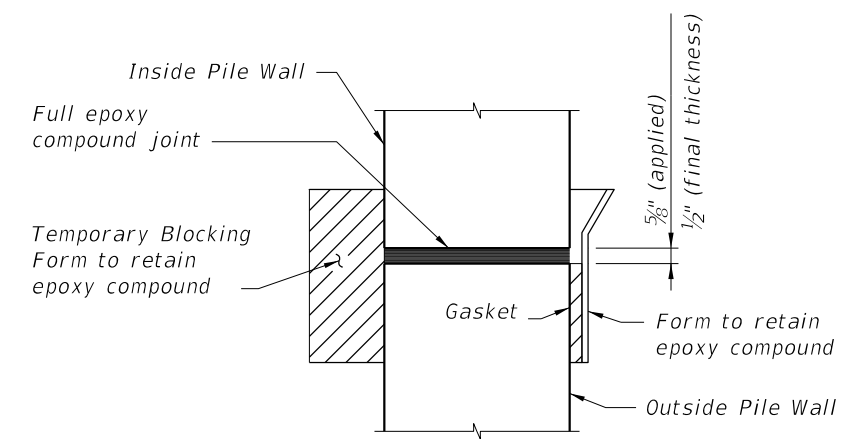

DETAIL "A"

10/6/2025 2:53:53 PM

LAST REVISION	01/01/16	DESCRIPTION:
---------------	----------	--------------



FY 2026-27
STANDARD PLANS

60" PRESTRESSED CFRP & SS CONCRETE
CYLINDER PILE

SS PRESTRESSED PILE DETAILS

INDEX
455-160

SHEET
3 of 3