

NOTES:
 1. A Pull Post Assembly is required at maximum intervals of 500'-0". See Sheet 3.

* Do not anchor Fencing to the top of Traffic Railings.

FENCING NOTES

FENCE INSTALLATION:
 Install posts plumb (within a tolerance of $\pm 1\frac{1}{2}$ "). Use shim plates as required to achieve plumb. The required quantity and thickness of shim plates will be determined in the field. Install chain link fence in accordance with ASTM F567 as applicable.

TRAFFIC RAILING DETAILS:
 See Superstructure Sheets for Traffic Railing details.

LIMITS OF FENCING:
 Limits of fencing are from begin of approach slab at Begin Bridge to end of approach slab at End Bridge, unless otherwise shown in the plans.

PAYMENT:
 Payment will be made under Fencing, Type R. Payment includes all materials and labor required to complete installation of the fence.

CROSS REFERENCE:
 For Table of Fence Components, Table of Post Attachment Components, View A-A and Detail "A" see Sheet 2.
 For Pull Post Assembly Detail for Traffic Railing see Sheet 3.

10/6/2025 3:27:55 PM

LAST REVISION 11/01/23	REVISION	DESCRIPTION:		FY 2026-27 STANDARD PLANS	BRIDGE FENCING ON BARRIER (CURVED TOP)	INDEX 550-013	SHEET 1 of 3
---------------------------	----------	--------------	---------------------------------------------------------------------------------------	------------------------------	----------------------------------------	------------------	-----------------

TABLE OF CHAIN LINK FENCE COMPONENTS		
COMPONENT	ASTM DESIGNATION	COMPONENT INFORMATION
Posts	F1083	Galvanized Steel Pipe - 3 1/2" NPS, Schedule 40 Regular Grade
Chain Link Fabric (2" mesh with twisted top and knuckled bottom selvage)	A392	Zinc Coated Steel - 9 gage (coated wire diameter), Class 2 Coating
	A491	Aluminum Coated Steel - 9 gage (coated wire diameter)
	F668	Polyvinyl Chloride (PVC) Coated Steel - 9 gage Class 2b
Tie Wires	F626	Zinc Coated Steel Wire - 9 gage
Brace Bands	F626	12 Gage (Min. thickness) x 3/4" (Min. width) Steel Bands (Beveled or Heavy)
Tension Bars	F626	3/16" (Min. thickness) x 3/4" (Min. width) x 6'-10" (Min. height) Steel Bars
Tension Bands	F626	14 Gage (Min. thickness) x 3/4" (Min. width) Steel Bands
Miscellaneous Fence Components	F626	Zinc Coated Steel ~ (includes post or loop caps, horizontal and brace rail ends, combination rail ends, boulevard clamps and all other miscellaneous fittings & hardware)
Tension Wire	A824 & A817	Type II (Zinc Coated Steel Wire) - 7 gage, Class 4 Coating
		Type I (Aluminum Coated Steel Wire) - 7 gage
Hog Rings	F626	Zinc Coated Steel Wire - 12 gage
Brace Rails	F1083	Galvanized Steel Pipe - 1 1/4" NPS, Schedule 40 Regular Grade

TABLE OF POST ATTACHMENT COMPONENTS		
COMPONENT	ASTM DESIGNATION	COMPONENT INFORMATION
Pipe Clamps	A36 or A709 Grade 36	1/4" Steel R
Base Plates	A36 or A709 Grade 36	3/4" Steel R
Shim Plates	A36 or A709 Grade 36 or B209 Alloy 6061-T6 or B221 Alloy 6063-T5	Plate thicknesses as required. Holes in shim plates will be 3/4" Ø. For edge shims match the edge length of the base plate with a min. width of 3/4". Apply adhesive bonding material bed of 1-1/2" (Min.) wide
Spacers	-	Plate thickness varies based on traffic railing type (See Detail "A")
Pipe Clamp Connection	Adhesive Anchor Rods	F1554 Grade 36
	C-I-P Anchor Rods	F1554 Grade 36
Bolts	A307	3/8" Ø x 4 3/4" Hex Head Bolts for Pipe Clamp Connections to Posts
Nuts	A563	Hex Nuts for Pipe Clamp Connections
Washers	F436	Flat Washers for Pipe Clamp Connections
Bearing Pads (Plain Neoprene)	-	In accordance with Specification Section 932 for Ancillary Structures

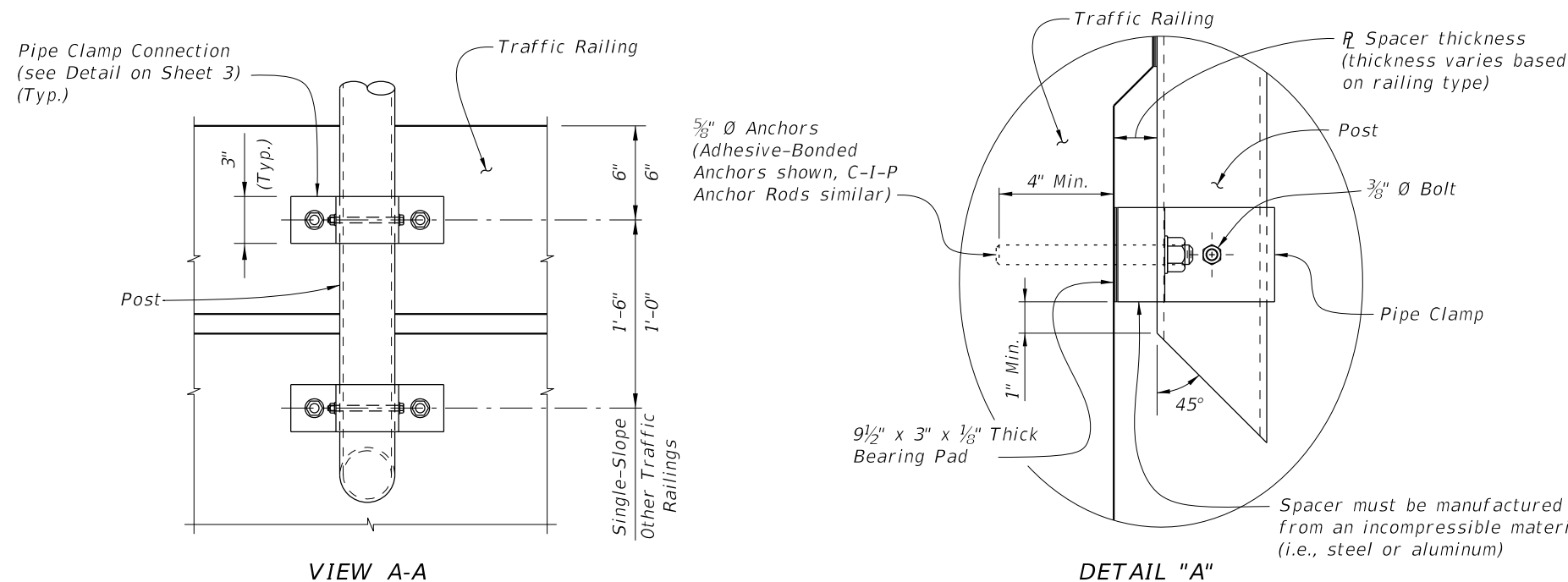

POST ATTACHMENT NOTES

ANCHOR RODS, NUTS AND WASHERS:
After the nuts have been tightened, distort the Anchor Rod threads to prevent removal of the nuts. Coat distorted threads and exposed trimmed ends of anchors with a galvanizing compound in accordance with Specification Section 562.

COATINGS:
Hot-dip galvanize all Nuts, Washers, Bolts, C-I-P Anchor Rods, Adhesive Anchors and Fence Framework (Posts, Internal Sleeves, Shim Plates, Base Plates, Pipe Clamps and Spacers) in accordance with Specification Section 962. Hot-dip galvanize Fence Framework after fabrication.

ADHESIVE-BONDED ANCHORS AND DOWELS:
Adhesive Bonding Material Systems for Anchors and Dowels will comply with Specification Section 937 and be installed in accordance with Specification Section 416. Cutting of reinforcing steel is permitted for drilled hole installation.

WELDING:
All welding will be in accordance with the American Welding Society Structural Welding Code (Steel) ANSI/AWS D1.1 (current edition). Weld metal will be E60XX or E70XX. Nondestructive testing of welds is not required.

CROSS REFERENCE:
For location of View A-A and Detail "A" see Sheet 1.

10/6/2025 3:28:01 PM

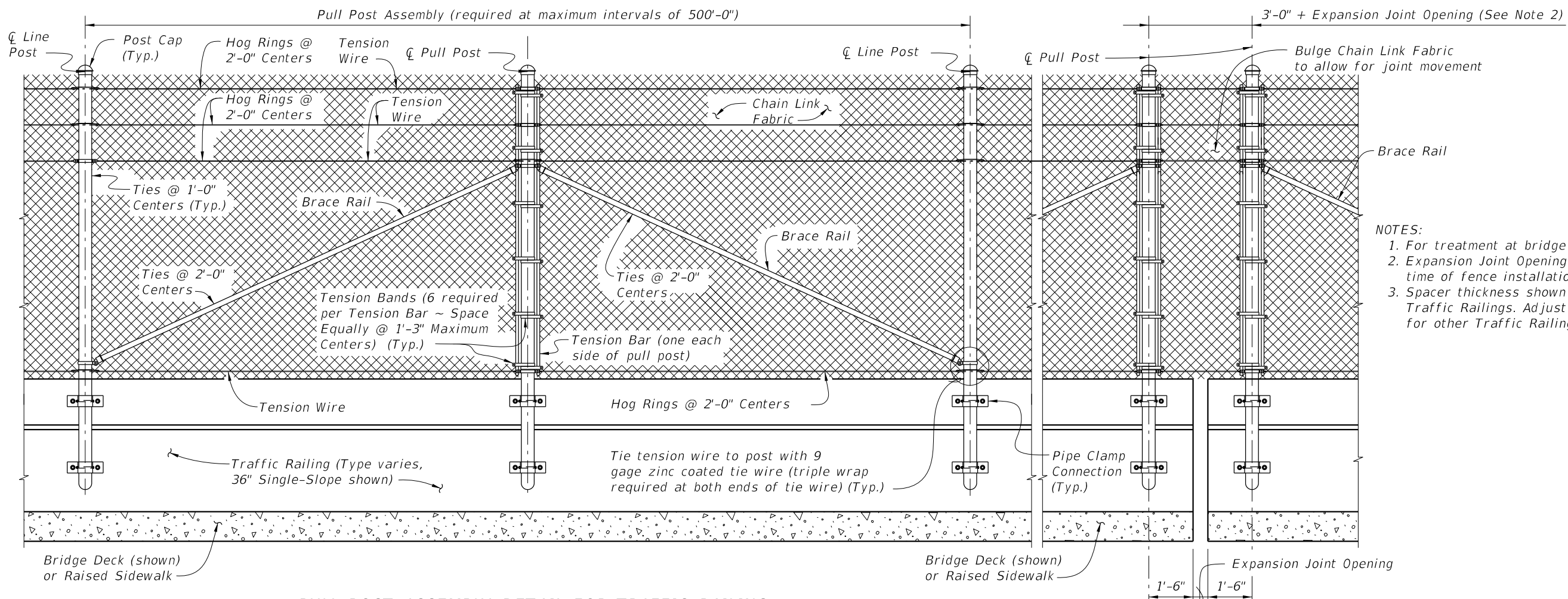

PULL POST ASSEMBLY DETAIL FOR TRAFFIC RAILING

EXPANSION ASSEMBLY DETAIL

(Required only at expansion joint locations where total movement exceeds 6")

- NOTES:**
1. For treatment at bridge ends, see Sheet 1.
 2. Expansion Joint Opening is the width at the time of fence installation.
 3. Spacer thickness shown is for Single-Slope Traffic Railings. Adjust thickness as required for other Traffic Railings.

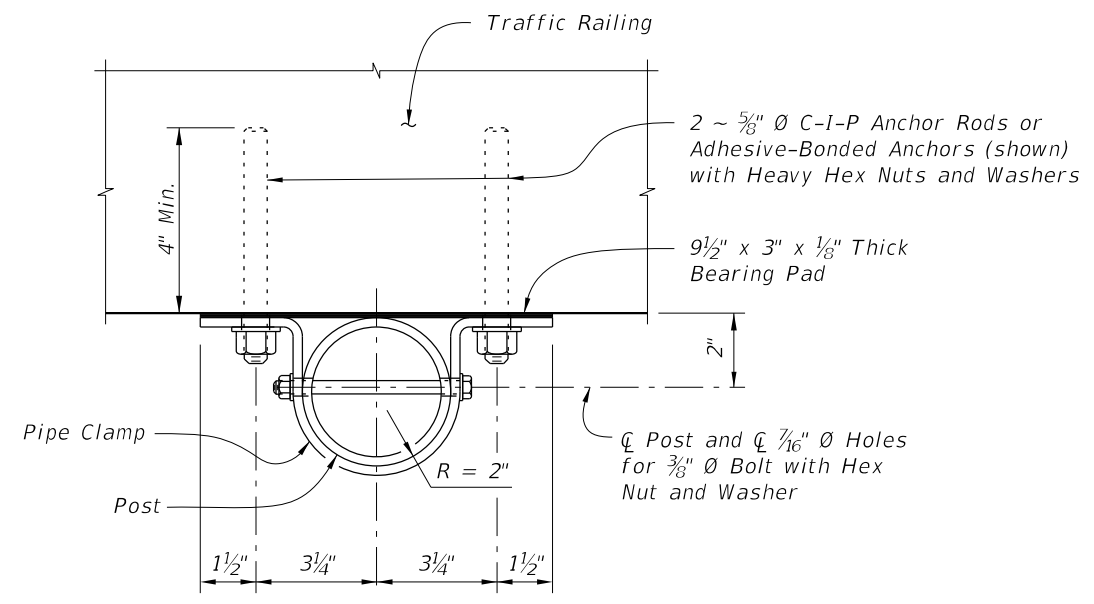

PIPE CLAMP CONNECTION DETAIL
(Connection without spacer shown, Connection with spacer similar)

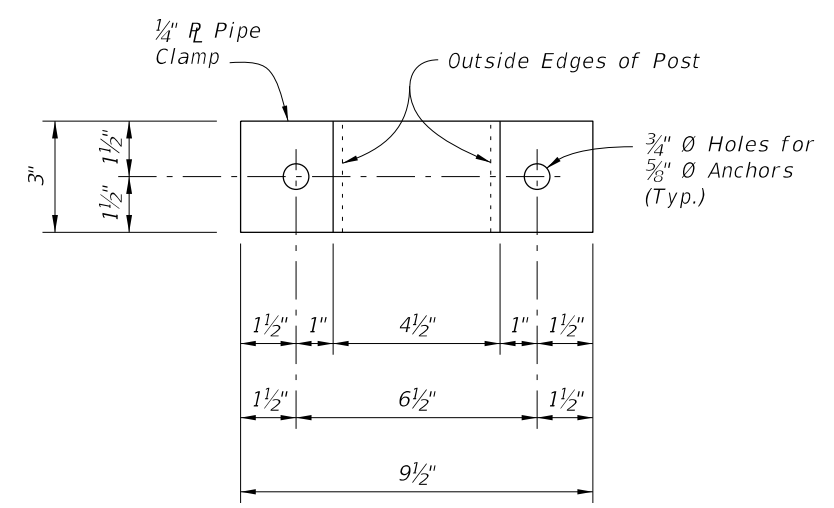

PIPE CLAMP DETAIL

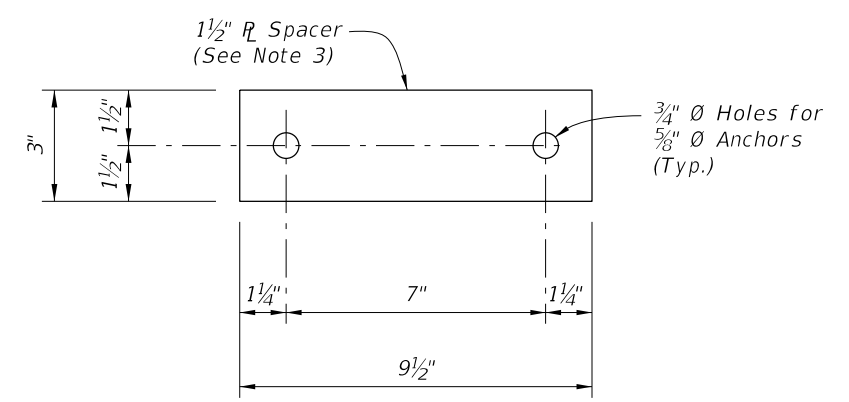

SPACER DETAIL

(Must be manufactured from an incompressible material (i.e., steel or aluminum))

10/6/2025 3:28:07 PM

LAST REVISION 11/01/23	REVISION	DESCRIPTION:		FY 2026-27 STANDARD PLANS	BRIDGE FENCING ON BARRIER (CURVED TOP)	INDEX 550-013	SHEET 3 of 3
---------------------------	----------	--------------	--	-------------------------------------	-----------------------------------------------	-------------------------	------------------------