

SunGuide®:

Release 8.2 Installation Notes

SunGuide-IN-8.2



Prepared for:

Florida Department of Transportation
Traffic Engineering and Operations Office
605 Suwannee Street, M.S. 90
Tallahassee, Florida 32399-0450
(850) 410-5600

July 12, 2022

Document Control Panel			
File Name:	SunGuide-IN-8.2.docx		
File Location:	SunGuide CM Repository		
CDRL:	n/a		
	Name	Initial	Date
Created By:	Adam Clauss, SwRI	ASC	09/04/08
Reviewed By:	Steve Dellenback, SwRI	SWD	10/24/08
	Steve Dellenback, SwRI	SWD	01/08/09
	Steve Dellenback, SwRI	SWD	03/06/09
	Steve Dellenback, SwRI	SWD	04/13/09
	Steve Dellenback, SwRI	SWD	05/15/09
	Robert Heller, SwRI	RWH	06/17/10
	Tucker Brown, SwRI	TJB	11/09/10
	Hector Iruegas, SwRI	HAI	11/18/10
	Tucker Brown, SwRI	TJB	02/11/11
	Hector Iruegas, SwRI	HAI	6/22/12
	Tucker Brown, SwRI	TJB	04/15/13
	Robert Heller, SwRI	RWH	05/15/13
	Roger Strain, SwRI	RLS	09/13/13
	Tucker Brown, SwRI	TJB	09/22/14
Modified By:	Adam Clauss, SwRI	ASC	10/24/08
	Adam Clauss, SwRI	ASC	11/17/08
	John Brisco, SwRI	JSB	01/08/09
	Adam Clauss, SwRI	ASC	03/06/09
	Adam Clauss, SwRI	ASC	04/13/09
	Adam Clauss, SwRI	ASC	05/15/09
	John Brisco, SwRI	JSB	06/22/09
	John Brisco, SwRI	JSB	02/11/10
	John Brisco, SwRI	JSB	03/25/10

Installation Notes

	John Brisco, SwRI	JSB	05/07/10
	John Brisco, SwRI	JSB	05/10/10
	John Brisco, SwRI	JSB	05/25/10
	John Brisco, SwRI	JSB	06/15/10
	John Brisco, SwRI	JSB	11/04/10
	Tucker Brown, SwRI	TJB	11/18/10
	John Brisco, SwRI	JSB	02/11/11
	Roger Strain, SwRI	RLS	02/11/11
	Tucker Brown, SwRI	TJB	08/08/11
	Tucker Brown, SwRI	TJB	06/22/12
	Tucker Brown, SwRI	TJB	08/01/12
	Hector Iruegas, SwRI	HAI	04/11/13
	Ansley Skillern, SwRI	AJS	09/13/13
	Tucker Brown, SwRI	TJB	10/11/13
	Adam Hoffman, SwRI	AGH	7/11/14
	Tucker Brown, SwRI	TJB	07/30/15
	Ansley Skillern, SwRI	AJS	01/05/16
	Tucker Brown, SwRI	TJB	03/08/17
	Tucker Brown, SwRI	TJB	09/25/17
	Tucker Brown, SwRI	TJB	02/22/18
	Tucker Brown, SwRI	TJB	12/12/18
	Tucker Brown, SwRI	TJB	10/02/19
	Tucker Brown, SwRI	TJB	11/17/20
	Tucker Brown, SwRI	TJB	08/24/21
	Tucker Brown, SwRI	TJB	07/12/22
Completed By:			

Table of Contents

	Page
List of Figures	ii
Acronyms.....	iii
Revision History.....	iv
1. Scope	1
1.1 Document Identification	1
1.2 Project Overview.....	1
1.3 Related Documents	1
1.4 Contacts	2
2. Installation Notes.....	3
2.1 Upgrade Procedure.....	3
2.2 Configuration Files Backup List.....	6
2.3 Post Installation Step	6
2.4 Operator Map Troubleshooting	7
2.5 Release Notes	7

List of Figures

	Page
Figure 1 – High-Level Architectural Concept	1

List of Acronyms

CCTV	Closed Circuit Television
COTS	Commercial-Off-The-Shelf
DLL.....	Dynamics Link Library
DMS.....	Dynamic Message Sign
DOT	Department of Transportation
FDOT	Florida Department of Transportation
GUI	Graphical User Interface
IN	Installation Notes
ITN.....	Invitation to Negotiate
ITS.....	Intelligent Transportation Systems
SPARR.....	Smart Phone Application for Road Rangers
SSL.....	Secure Sockets Layer
SwRI	Southwest Research Institute®
TSS.....	Transportation Sensor Subsystem
VDD.....	Version Description Document
XML.....	Extensible Markup Language

Revision History

Revision	Date	Changes
4.0.0	September 10, 2008	Initial release
4.0.1	September 29, 2008	Updated based on IV&V results as well as new instructions for updating the event type table
4.0.2	October 3, 2008	Updated with CMB revised Event Lists, SAE codes and change of “Accident to Crash” terminology
4.1.0	October 24, 2008	Updated for release 4.1.0.
4.1.1	November 17, 2008	Updated for release 4.1.1.
4.1.2	January 8, 2009	Updated for release 4.1.2.
4.1.3	March 6, 2009	Updated for release 4.1.3.
4.2.0	May 15, 2009	Updated for release 4.2.0.
4.2.2	June 25, 2009	Updated for release 4.2.2.
4.3.0	February 11, 2010	Updated for release 4.3.0.
4.3.2	March 25, 2010	Updated for release 4.3.2.
4.3.3	May 7, 2010	Updated for release 4.3.3.
5.0.0	May 10, 2010	Updated for release 5.0.0.
5.0.1	May 25, 2010	Updated for release 5.0.1.
5.0.2	June 15, 2010	Updated for release 5.0.2.
5.0.3	June 21, 2010	Updated for release 5.0.3
5.0.4	November 4, 2010	Updated for release 5.0.4
5.0.5	February 11, 2010	Updated for SPARR enhancement (release 5.0.5).
5.1.0	August 9, 2011	Updated for release 5.1.0
5.1.1	June 22, 2012	Updated for release 5.1.1
6.0.0	April 11, 2013	Updated for release 6.0.0
6.0.0p1	September 13, 2013	Updated for release 6.0.0p1
6.0.0p2	October 11, 2013	Updated for release 6.0.0p2
6.1.0	July 11, 2014	Updated for release 6.1.0
6.1.0p1	July 30, 2015	Updated for release 6.1.0p1
6.2.0	January 5, 2016	Updated for release 6.2.0
7.0.0	March 8, 2017	Updated for release 7.0.0
7.1.0	September 25, 2017	Updated for release 7.1.0
7.1.1	February 22, 2018	Updated for release 7.1.1
7.1.2	December 12, 2018	Updated for release 7.1.2
7.2	October 2, 2019	Updated for release 7.2
8.0	November 17, 2020	Updated for release 8.0
8.1	August 24, 2021	Updated for release 8.1
8.2	July 12, 2022	Updated for release 8.2

1. Scope

1.1 Document Identification

This document serves as the Installation Notes (IN) for the SunGuide® Release 8.2 software.

1.2 Project Overview

The Florida Department of Transportation (FDOT) is conducting a program that is developing SunGuide software. The SunGuide software is a set of Intelligent Transportation System (ITS) software that allows the control of roadway devices as well as information exchange across a variety of transportation agencies. The goal of the SunGuide software is to have a common software base that can be deployed throughout the state of Florida. The SunGuide software development effort is based on ITS software available from the state of Texas; significant customization of the software is being performed as well as the development of new software modules. The following figure provides a graphical view of the software to be developed:

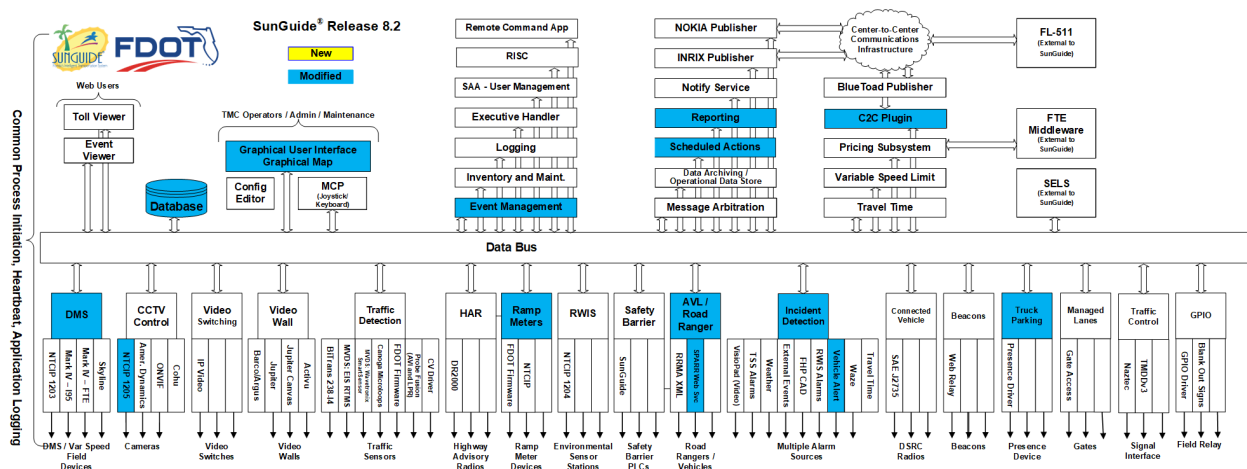

Figure 1 - High-Level Architectural Concept

1.3 Related Documents

Additional information regarding the SunGuide project can be found in the following documents and electronic publications:

- FDOT Scope of Services: *BE492, Standard Written Agreement for SunGuide Software Support, Maintenance, and Development, Exhibit A: Scope of Services*. December 14, 2017.
- Notice to Proceed: Letter to Southwest Research Institute® (SwRI®) for BE492, December 14, 2017
- Letter of Authorization 013: Letter to SwRI for BE492, March 4, 2022
- SunGuide Project website: <http://sunguide.datasys.swri.edu>.

1.4 Contacts

The following are contact persons for the SunGuide software project:

- Derek Vollmer, ITS Section, TSM&O, Central Office,
derek.vollmer@dot.state.fl.us, 850-410-5606
- Christine Shafik, ITS Section, State TSM&O Software Engineer, Central Office,
Christine.Shafik@dot.state.fl.us, 850-410-5615
- Carla Holmes, Gresham Smith Project Manager,
Carla.Holmes@dot.state.fl.us, 678-518-3654
- Tucker Brown, SwRI Project Manager,
tbrown@swri.org, 210-522-3035
- AJ Skillern, SwRI Software Project Manager,
askillern@swri.org, 210-522-6295

For current contact information please refer to this link: <http://sunguidesoftware.com/contact-us>

2. Installation Notes

This document is intended to be a “companion” document to the SunGuide Version Description Document (VDD). This document will provide detailed notes and tips on how to upgrade the SunGuide software to version 8.2 from version 8.1.

Prior to upgrading the database to version 8.2 please read all instructions and ensure that your system is up to date with v8.1. The 8.2 upgrade scripts will re-run any necessary 8.1 Hotfix scripts prior to running the 8.2 scripts.

NOTE: It is highly recommended that you test the database upgrade procedure before applying it to any Production database. If any errors are encountered, the database must be reimported and the script attempted again after the failure is resolved. If you would like SwRI to perform a test, please make arrangements with SwRI and Central Office.

2.1 Please Upgrade Procedure

Please follow the steps below to complete the SunGuide installation. **Please take care more any notes in red as they are specific to this install.**

1. Please close all active events prior to the upgrade.
2. Shut down all SunGuide process including Status Logger and Executive Handler.
3. SunGuide Database
 - a. Backup the existing SunGuide database by using the SQL Server Import and Export Wizard.
 - i. It is recommended that the script be run from the SunGuide database server but if not, please ensure you are able to access “sqlcmd” from the command line.
 - ii. From the installation media, run the “runMe.bat” file from the “DatabaseScripts/8.2 Release/SqlServer” folder as an Administrator
 - iii. Enter the correct database information and config file path.
 - iv. **PLEASE NOTE: There is a prompt at the beginning of the scripts for the Status Logger Database**
 - v. Review the log file for errors.
4. SunGuide Application Servers
 - a. If using Windows Server 2008 or higher, ensure the following:
 - i. Install IIS and IIS 6 Management Compatibility role and all Sub-Roles. Note that Windows Server 2008 and 2012 use a new version of IIS (7.0 and 7.5) which are not compatible with IIS 6 Applications. When installing IIS, install everything except “Server Side Includes” under the “Application Development” section.
 - b. Ensure both versions of .NET, 2.0 and 4.0 are installed on all application servers. Please make sure .NET 4.6.2 is also installed.
 - i. Once installed the .NET 4.0 components must be registered within IIS.
 - a. For x86, use the following command
“c:\windows\Microsoft.Net\Framework\v4.0.30319>aspnet_regiis -i”

- b. For x64, use the following command,
“c:\windows\Microsoft.Net\Framework64\v4.0.30319>aspnet_regis -i”
- c. Backup the various configuration files (plural) according to the list in the Backup List section below.
- d. Uninstall SunGuide via the Control Panel -> Add/Remove Programs on all Application Servers. Reboot if prompted.
- e. Ensure that the following folders were deleted on each SunGuide Application Server:
 - i. C:\inetpub\wwwroot\OperatorMap (this path may be located on a shared location if running in a clustered environment)
 - ii. C:\inetpub\wwwroot\SunGuideAdmin (this path may be located on a shared location if running in a clustered environment)
 - iii. C:\Program Files\Florida Department of Transportation
- f. Upgrade config.xml file using the Configuration File Editor and the SunGuide Release 8.2 configuration schema.
- g. Install SunGuide via the installer on all application servers. Reboot if asked.
- h. **Restore configuration. Please read through the entire step before continuing.**
 - i. Restore the various configuration files according to the Backup List section below.
 - ii. If restoring the backed up copy of your “OMInterface.dll.config.xml” verify the following entries to the file.

```
<add key="deploymentName" value="<NAME>"  
<add key="deploymentPath"  
value="http://<MAPHOST>/OperatorMap/OperatorMap.application" />
```

<NAME> in the first entry should be the unique deployment identifier for your installation, such as your center ID or location (e.g. ‘District 9’ or ‘Broward County’). If installing multiple SunGuide deployments in the same center, each “deploymentName” will have to be unique in order to run each installation’s Operator Map from a terminal.

In the second entry, <MAPHOST> should be the network host name or IP address where the map can be reached. By default, the <MAPHOST> value in the URL is the hostname of the server the installer was run from. The URL may need to be updated for a clustered environment to include the clustered host name.

If you modify either of these two new values, you *must* sign the map again by running the sign.exe executable application in the Operator Map directory.

The following tags should be added to your old OMInterface.dll.config.xml if you are restoring the backed up version.

If you wish to use the Crash Reporting, this must be configured for your environment.

- `<add key="sendCrashReport" value="true"></add>`
 - Whether or not to send reports on behaviors that might cause the map to crash.
 - `<add key="crashReportAddress" value="https://crashreport.datasys.swri.edu/SG/CrashReportService/Report.svc"></add>`
 - Address of the server to report crash reports.
 - This is the correct value. Do not change the value.
- iii. The map tiles location in the “OMInterface.dll.config.xml” file must match the actual location of the map tile files. The default location is a folder named “Tiles” under the “OperatorMap” folder. To change the default location, edit the “value” attribute associated with the “key” attribute named “tilesets”. The “value” attribute must contain pairs of strings that define the label of the tile set and the file system path of the tileset. The file path can be relative to the “OperatorMap” folder or it can be an absolute path. Note that neither the label nor the file path may contain any whitespace characters
5. SunGuide share data
- a. Report files:
 - i. Verify the locations and user permissions of the report templates and exported reports folder as specified in the <RS> section of the config file.
 - ii. Copy the newly installed reports to the configured location on the share (see <RS> section in config file). By default, these files are installed to C:\Report Templates.
 - iii. If SunGuide is configured to run on an SQL Server database, use the SQL Server reports instead of the default Oracle reports. On the installation media, these are in the ReportTemplates\SQL Server Delivered folder. SwRI support staff will directly coordinate with the district system administrators to provide the updated reports that will be specific to the database from which they will extract data.
 - b. Give NETWORK_SERVICE full access to the OperatorMap folder; use the Advanced Tab in the file security dialog to apply to all subfiles and subfolders.
6. IIS Configuration performed on each server hosting the web apps / S: drive:
- a. If using Windows Server 2008 or 2012, do the following:
 - i. Change the "Default Web Site" to an Application Pool with "Classic .NET AppPool" or an Application Pool set to Classic
 - ii. Change the Application Pool for SunGuideAdmin to "Classic .NET AppPool" or an Application Pool set to Classic
 - iii. Double click on "Authentication" located in the IIS section of "Default Web Site", select ASP .NET Impersonation and click "Enable" on the right hand side
 - iv. Double click on "Directory Browsing" located in the IIS section of "Default Web Site" and click "Enable" on the right hand side (if disabled)

- v. Navigate to "Request Filtering" located in the IIS section of "Default Web Site", once there highlight ".config", right click and remove it from list
 - vi. Turn off Windows Firewall using the Domain, Private and Public tab
 - b. MOVE the GROUP containing the network name used to access the operator map if in clustered configuration via cluster administrator to the appropriate server.
 - c. VERIFY the correct version, ASP.NET 4.0, is set for SunGuide admin.
 - d. VERIFY the Event Viewer, Toll Viewer, etc. come up; else, reconfigure in IIS appropriately.
 - i. Check the ASP.NET version of IIS (should be 4.0),
 - ii. Database location in the TollViewerSvc's web.config file
 - iii. Default documents in the Event Viewer website properties,
 - iv. Host string in the web site listener that allows the Event Viewer website to listen on port 80 for that string while all other strings are accepted by the default website.
 - v. The default.htm file in the root should contain correct links to point to the Event Viewer and TollViewer if necessary.
 - vi. Repeat this IIS Configuration step if in a cluster environment for all servers that will be hosting the web applications.
 7. Full System Test: Test the system in its entirety to verify that everything is functioning properly to identify and resolve any configuration/deployment issues.

2.2 Configuration Files Backup List

If the installation to be performed is on servers currently configured to execute SunGuide, the following files should be backed up prior to installation so that they can be reused once the new installation is performed.

- config.xml – primary configuration file that contains the settings for all the SunGuide subsystems and drivers
- FL-ATIS_FloodGate_Data.xml – contains the floodgate message “slot” configuration data used by the Floodgate GUI
- IpVideoDevices.xml – provides model specific settings for video devices
- SnapshotDevices.xml – defines video capture devices and corresponding IP video decoder devices
- OMInterface.dll.config.xml – Operator Map client configuration settings
- ProcessList.xml – Executive Handler Server's list of installed services
Note: This is only necessary if the system is not operating in a clustered environment. The Installer will auto-generate a ProcessList.xml for all installed SunGuide application processes.
- Web.config – If uninstalling and re-installing any C2C web services, each web service contains a web.config file for C2C configuration.

2.3 Post Installation Step

- Ensure 4.h.ii of the Upgrade Procedure was performed!

2.4 Operator Map Troubleshooting

- Try uninstalling Operator Map from the list of Add or Remove Programs in the Control Panel and then reinstall from the web site.

2.5 Release Notes

- None