

## Section 4.4

# ROUNABOUT MARKINGS

The Department's standards for this section are shown in [Chapter 3C of the MUTCD](#).

## Section 4.5

### EXPRESS LANE MARKINGS

#### 4.5.1 PURPOSE

Express lanes markings shall conform to the [FDOT Design Manual \(FDM\)](#) and to the [MUTCD](#). This section is intended only as a supplement to these documents to provide guidance on pavement markings for express lanes.

#### 4.5.2 DEFINITIONS

**Buffer Area or Buffer Space.** The pavement space between the express lane(s) and general use or general toll lanes that is designated by a pattern of standard longitudinal pavement markings that are wider than a normal or wide lane line marking.

**Buffer Width.** The lateral gap between the express lane(s) and general use or general toll lanes as measured from centerline of 8-inch longitudinal pavement marking.

**Slip Ramp Access Type.** Provides connections between the express lanes and general use or general toll lanes using breaks in the separation type and are typically facilitated by an exclusive lane.

**Toll Gantry.** Truss structure supporting toll equipment over the roadway.

**Tolling Area.** Section of roadway underneath the toll gantry.

**Weave Lane Access Type.** Provides interim access to express lanes using a break in the separation type that has an additional lane to accommodate weaving movements. Weaving and speed changes required for merging between the general use or general toll lanes and the express lanes occurs in a separate weave lane.

**Weave Zone Access Type.** Provides interim access to express lanes using a break in the separation type allowing for simultaneous ingress and egress.

#### 4.5.3 THE WORDS 'EXPRESS' AND 'ONLY' PAVEMENT MARKINGS IN EXPRESS LANES

- (1) The words 'EXPRESS' and 'ONLY' shall be placed in advance of express lanes access points and co-located with overhead advance guide signs under the following conditions:
  - (a) When the general use or general toll lane transitions directly into an express lane.

- (b) When the general use or general toll lane directly connects from a surface street (see [Figure 2G-26 of the MUTCD](#)).
- (2) The word 'EXPRESS' shall be placed at the immediate point of entry under the following conditions:
- (a) When the slip ramp transitions directly into the express lanes.
  - (b) When the slip ramp from the general use lanes or general toll lanes merges directly into the express lanes.
- (3) The word 'ONLY' shall NOT be used under the following conditions:
- (a) Weave zone access type.
  - (b) Weave lane access type.
  - (c) At any point beyond the entry gore where there is no legal option to exit or enter the express lanes.

#### 4.5.4 CHEVRONS AND MARKERS IN BUFFER AREA

Chevron and markers in the buffer area shall meet the buffer width requirements according to [FDM 211](#). Chevrons crosshatch markings in buffer areas ([Figure 4.5-1](#)) with tubular markers shall be installed as follows:

- (1) Buffer widths of two (2) feet or less shall not have chevrons.
- (2) Buffer widths greater than 2 feet to 12 feet:
  - (a) For slip ramp access type, add 18-inch white chevrons spaced at 100 feet within the slip ramp transition.
  - (b) For weave lane access type, add 18-inch white chevrons spaced at 100 feet within the weave lane transition.
  - (c) For weave zone access type, add 18-inch white chevrons spaced at 100 feet for 1000 feet on both sides of the weave area.
- (3) Buffer widths greater than 12 feet shall have 18-inch white chevrons spaced at 100 feet.

**Figure 4.5-1. Buffer Area Detail**

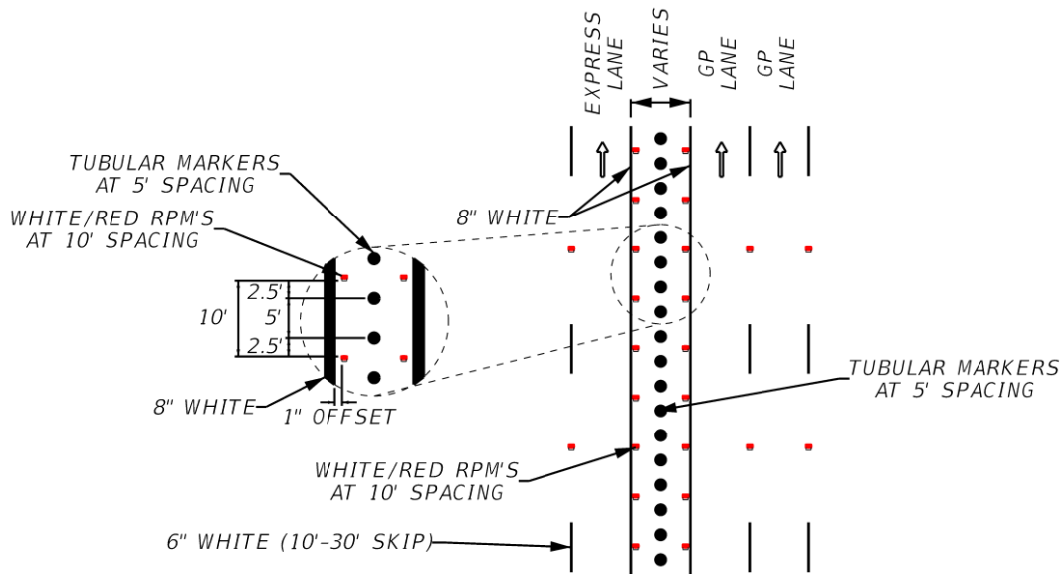

### 4.5.5 SPECIAL PAVEMENT MARKINGS WITHIN THE TOLLING AREA

- (1) Where there is more than one express lane, a solid 8-inch white stripe shall separate the lanes for 300 feet prior to the toll gantry and 50 feet past the toll gantry as shown in **Figure 4.5-2**.

**Figure 4.5-2. Striping Under Toll Gantry**

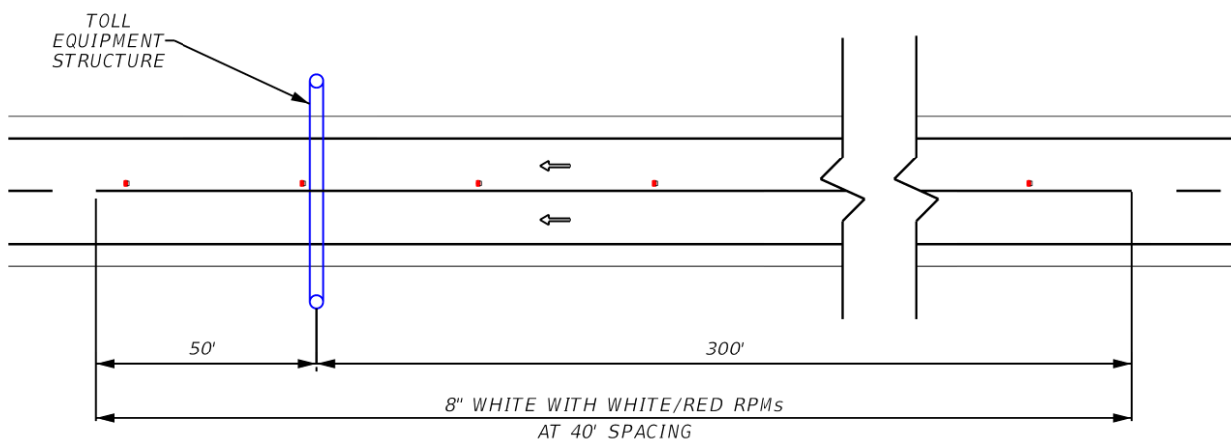

- (2) Tubular marker placement within the tolling area shall meet the buffer width requirements in accordance with [FDM 211](#):

- (a) Buffer widths less than 8 feet shall have one (1) tubular marker as shown in **Figure 4.5-1**.
- (b) Buffer widths between 8 feet and 12 feet shall have two (2) tubular markers evenly spaced transversely (as shown in **Figure 4.5-3**).
- (c) Buffer widths 12 feet and greater shall have three (3) tubular markers evenly spaced transversely.
- (d) Tubular markers or raised pavement markers shall not be installed on top of the loop or lead-in saw cut or sealant.

**Figure 4.5-3. Tubular Marker Placement within the Tolling Area for Buffer widths between 8 and 12 feet**

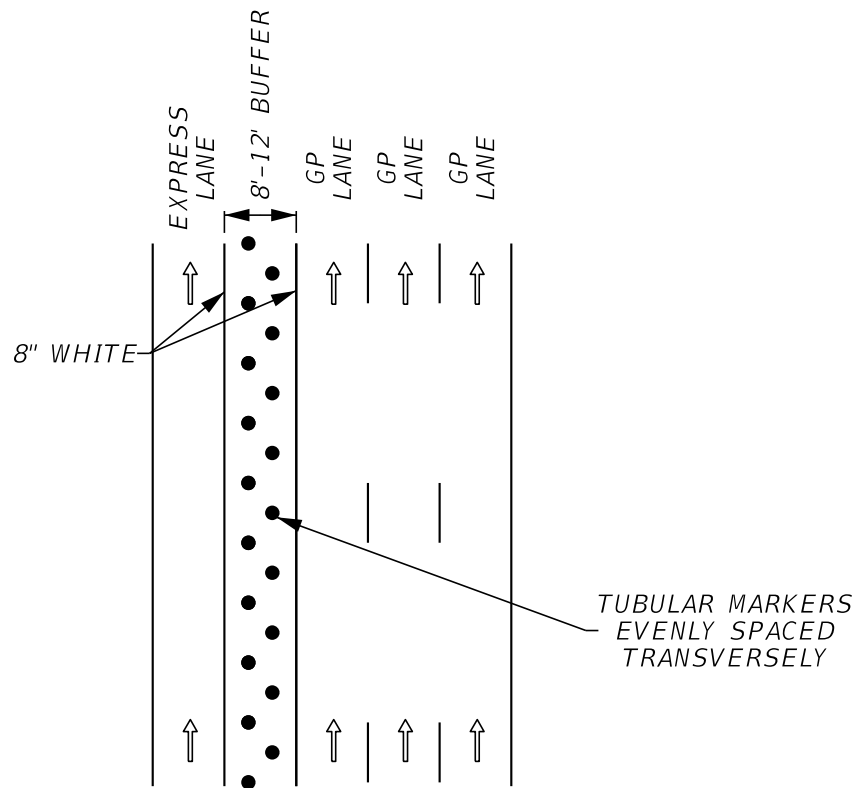

## Section 4.6

### USE OF INTERNALLY ILLUMINATED RAISED PAVEMENT MARKERS

#### 4.6.1 PURPOSE

To provide guidance for the uniform application of Internally Illuminated Raised Pavement Markers (IIRPMs) on the State Highway System.

#### 4.6.2 DEFINITIONS

Raised pavement markers are traffic control devices used as a positioning guide to supplement longitudinal pavement markings for enhanced nighttime and wet weather visibility. IIRPMs are permitted for use by [Chapter 3B of the MUTCD](#) as an equivalent alternative to Retroreflective Raised Pavement Markers (RRPMs). IIRPMs are steady-burn internally illuminated raised pavement markers installed in the roadway surface.

#### 4.6.3 APPLICATION

RRPMs are the Department's standard type of raised pavement marker. The use of IIRPMs should be limited to mitigation strategies for curves with any of the following:

- (1) Substandard horizontal alignment or super-elevation
- (2) Substandard lane widths
- (3) Substandard shoulder widths

#### 4.6.4 PROCEDURE

- (1) For supplementing or substituting longitudinal line markings, IIRPM spacing must comply with [Sections 3B.12 through 3B.14 of the MUTCD](#).
- (2) For all IIRPM applications on the State Highway System, a signed and sealed Traffic Engineering and Safety Study must be conducted to justify the use. [DIOEs](#) will coordinate with the District Maintenance Engineer to consult the location of these installations.

PROCEDURE



SIGNS



SIGNALS



MARKINGS



SPECIAL  
OPERATIONAL  
TOPICS



## Section 5.1

# GOLF CART CROSSING AND OPERATION ON THE STATE HIGHWAY SYSTEM

### 5.1.1 PURPOSE

The purpose of this section is to establish criteria and guidelines for safe operation of golf carts on authorized portions of the State Highway System.

### 5.1.2 GENERAL

- (1) The Department has developed this section in response to a growing public interest in using golf carts. Golf carts are increasingly used to make short trips for shopping, social and recreational purposes from nearby residential neighborhoods such as planned unit communities with golf courses. These passenger-carrying vehicles, although low-speed, offer a variety of advantages, including comparatively low-cost and energy-efficient mobility.
- (2) Golf cart use and operation on public roads is authorized only under certain circumstances as provided in [Section 316.212, F.S.](#) The intent of this section is to provide criteria and guidelines for authorizing golf cart crossings at designated locations along State Highway System and promote uniformity within the State. This section also provides safety recommendations to counties and municipalities wishing to enact ordinances authorizing the use of golf carts on sidewalks adjacent to or on the State Highway System within their corresponding jurisdictions.

### 5.1.3 DEFINITIONS

- (1) **Golf Cart.** A motor vehicle designed and manufactured for operation on a golf course for sporting or recreational purposes and that attain speeds of less than 20 miles per hour.
- (2) **Grade Separated Crossing.** A tunnel or overpass designed and constructed for the purpose of crossing a street or highway.
- (3) **Local Government.** A City or County as defined in [Section 11.45 \(e\), F.S.](#)
- (4) **State Roadway.** Any roadway of the State Highway System under jurisdiction of the State except limited access facilities.

### 5.1.4 PROCEDURE

- (1) Any golf cart crossing proposed for a location on the State Highway System shall be reviewed and approved by the appropriate [District Traffic Operations Engineer \(DTOE\)](#) prior to installation. The Department's preferred design for golf cart

- crossing of any state road shall be via grade separated facility.
- (2) A request from a local government shall be submitted to the appropriate [DTOE](#). Non-governmental entities wishing to obtain authorization for a golf cart crossings shall do so through the local government with jurisdictional authority.
  - (3) If the [DTOE's](#) review of available information supports the installation of a golf cart crossing based upon the criteria outlined in **TEM 5.1.5**, then a full engineering study prepared by a professional engineer licensed in the State of Florida representing the requester may be conducted.
  - (4) The criteria referenced in **TEM 5.1.5**, as documented in an engineering study, shall be met as a condition for approval of a golf cart crossing. The engineering study shall also contain the following information:
    - (a) Document the need for a golf cart crossing based on conditions set forth in [Section 316.212, F.S.](#), and verify the following:
      - The intersecting county or municipal road has been designated for use by golf carts.
      - A golf course or single mobile home park is constructed on either sides of a state road.
    - (b) Document all safety considerations with respect to intersecting sight distances, proximity to intersection and driveway conflict areas, number and configuration of approach lanes to signalized intersections and roadway speed and volume thresholds as described in **TEM 5.1.5** that can be satisfied at the proposed location.
    - (c) Document the proposed golf cart crossing and/or roadway segment location (Roadway ID and Mile Post) and corresponding signing, marking, and signal treatments (if applicable). A schematic layout should be provided over aerial photography or survey to show locations of signs, markings, and other treatments in proximity to existing traffic control devices.
    - (d) Document all crash history within the vicinity of the proposed golf cart crossing based upon a minimum three years of data.
  - (5) If the evaluation results in a decision not to authorize the installation of a golf cart crossing, the [DTOE](#) shall document the reasons and advise the local government of the findings. Meeting the minimum criteria outlined in this section does not guarantee approval of a request for a golf cart crossing.
  - (6) Prior to the approval of a golf cart crossing, coordination is necessary between the appropriate [District Traffic Operations Office](#), District Maintenance Office and local governments to determine any permitting requirements or responsibilities for maintenance.

Figure 5.1-1. Procedure Flowchart

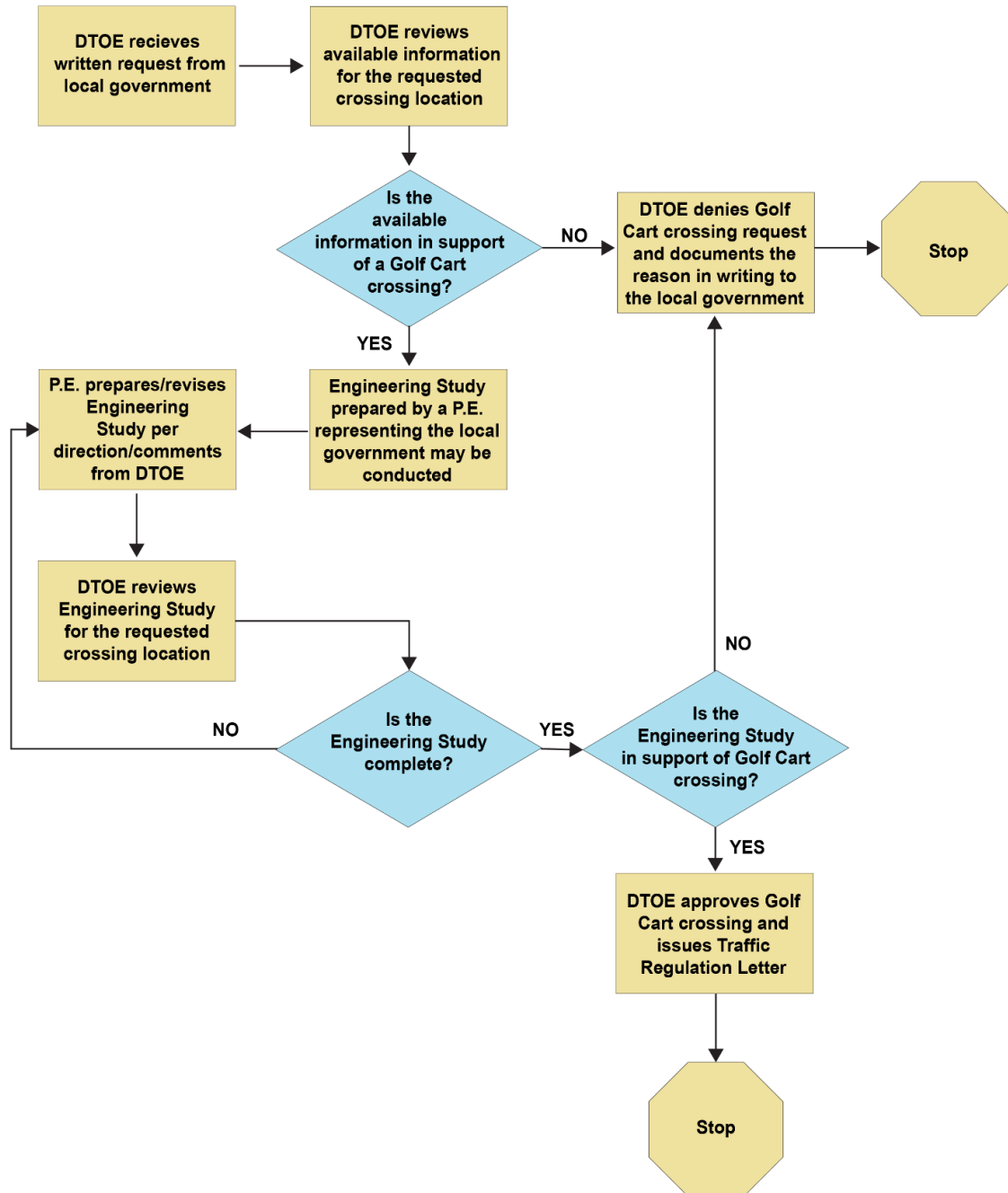

### 5.1.5 CRITERIA FOR APPROVAL OF CROSSING

- (1) **Mid-Block Crossing:** To be considered for a golf cart crossing at a mid-block location along any state road where a golf course or a single mobile home park is constructed or located on both sides of the roadway, the proposed location and roadway characteristics shall meet the following criteria:

- (a) Maximum vehicular volume of 15,000 Average Daily Traffic (ADT) or less along the roadway segment.
- (b) Maximum Posted Speed Limit of 40 miles per hour or less.
- (c) Maximum number of lanes is three (3) with or without bike lanes.
- (d) Maximum allowable median width is 15 feet or less.
- (e) Minimum distance to the nearest driveway, access point or pedestrian crosswalk is 350 feet in each direction.
- (f) Crossing along roadway tangents only with the nearest point of curvature at least 350 feet in each direction.
- (g) A clear and unobstructed view of the roadside on the approach to the crossing.
- (h) Signing and pavement markings are installed as shown in **Figure 5.1-2**.
- (i) Golf carts are the only vehicle permitted to use the designated crossing or to traverse State right-of-way. Other vehicles such as Low Speed Vehicles are strictly prohibited. See [320.01\(42\) F.S.](#)

**Figure 5.1-2. Mid-Block Crossing**

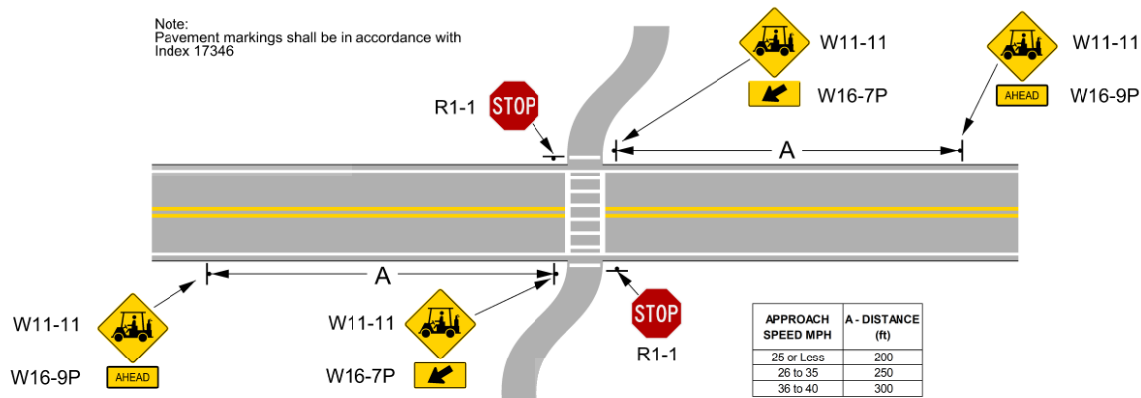

- (2) **Side Street Stop Controlled Intersections:** To be considered for a golf cart crossing at a roadway intersection with side street stop control, the location along any state road shall meet the following criteria:
  - (a) Side street maximum vehicular volume 1,200 ADT and AM/PM Peak Hour not to exceed 110 vehicles per hour single direction.
  - (b) Main street posted speed limit or 85th percentile intersection approach speed is 35 miles per hour or less.
  - (c) Maximum crossing distance for undivided roadways shall be equal to three

- (3) lanes or less not including any right turn lanes, bike lanes and crosswalks. For divided roadways of four (4) lanes or less, a minimum of twenty-two (22) feet median width is required (**Figure 5.1-4**).
- (d) Side street approaches should have an exclusive left turn lane and a shared through-right turn lane. Other lane approach configurations will be considered on case-by-case basis.
- (e) Side street intersection alignment shall be a 90 degrees (not more than 105 degrees) angle to the mainline tangent. Skewed or offset intersections are not recommended for golf cart crossings.
- (f) Approach stop signs and pavement markings shall be in accordance with [MUTCD](#) and [Standard Plans, Index 711-001](#).
- (g) Golf Cart signs (W11-11) should be placed on the mainline approach as shown in **Figure 5.1-3** and **Figure 5.1-4**.

**Figure 5.1-3. Stop-Controlled Crossing**

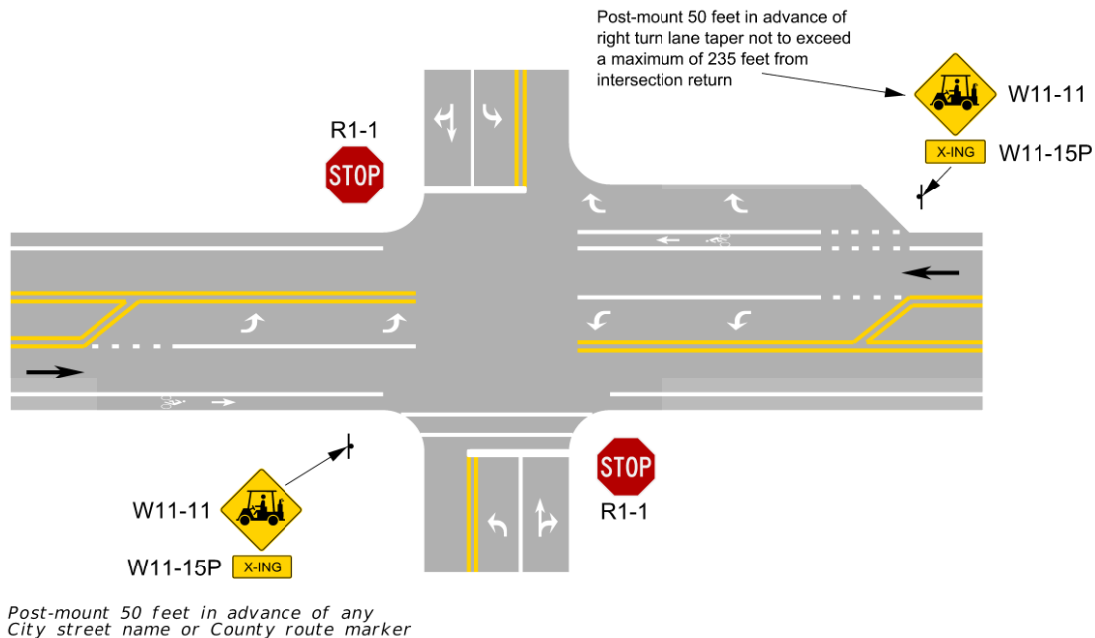

**Figure 5.1-4. Four-Lane Stop-Controlled Crossing**

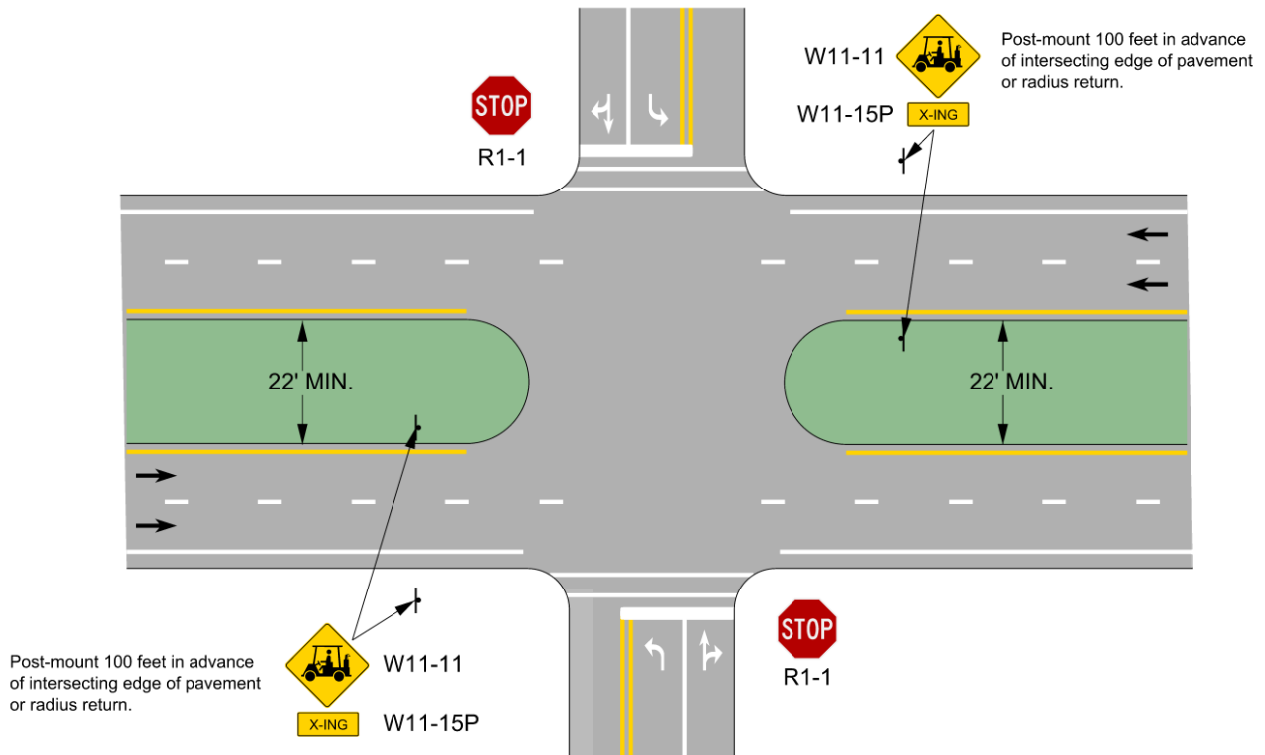

- (3) **Full Signalized Intersections:** To be considered for a golf cart crossing at a roadway intersection with full signal control, the location along any state road shall meet the following criteria:
- (a) Side street maximum vehicular volume 1,500 ADT and AM/PM peak hour not to exceed 200 vehicles per hour in single direction.
  - (b) Side street posted speed limit or 85th percentile intersection approach speed is 35 miles per hour or less.
  - (c) Maximum crossing distance equal to five (5) lanes or less not including any right turn lanes, bike lanes and crosswalks.
  - (d) Side street approaches should have at least one (1) exclusive left turn lane and at least one (1) exclusive through or shared through-right turn lane. Other lane approach configurations will be considered on a case-by-case basis.
  - (e) Side street intersection alignment shall be a 90 degrees (not more than 105 degrees) angle to the mainline tangent. Skewed or offset intersections are not recommended for golf cart crossings.
  - (f) Golf carts shall not use pedestrian crosswalks or sidewalk ramps for the

purpose of crossing the mainline state road.

- (g) Golf cart crossings are not permitted at “T” intersections.
- (h) For existing signalized “T” intersections, a proposed forth leg approach and receiving lane for the exclusive use of golf cart crossing shall not be permitted.
- (i) Approach traffic control signs and pavement markings shall be in accordance to [MUTCD](#) and [Standard Plans, Index 711-001](#).
- (j) Golf Cart signs (**W11-11**) should be placed on the side street approach as shown in **Figure 5.1-5**.

**Figure 5.1-5. Traffic Signal Controlled Crossing**

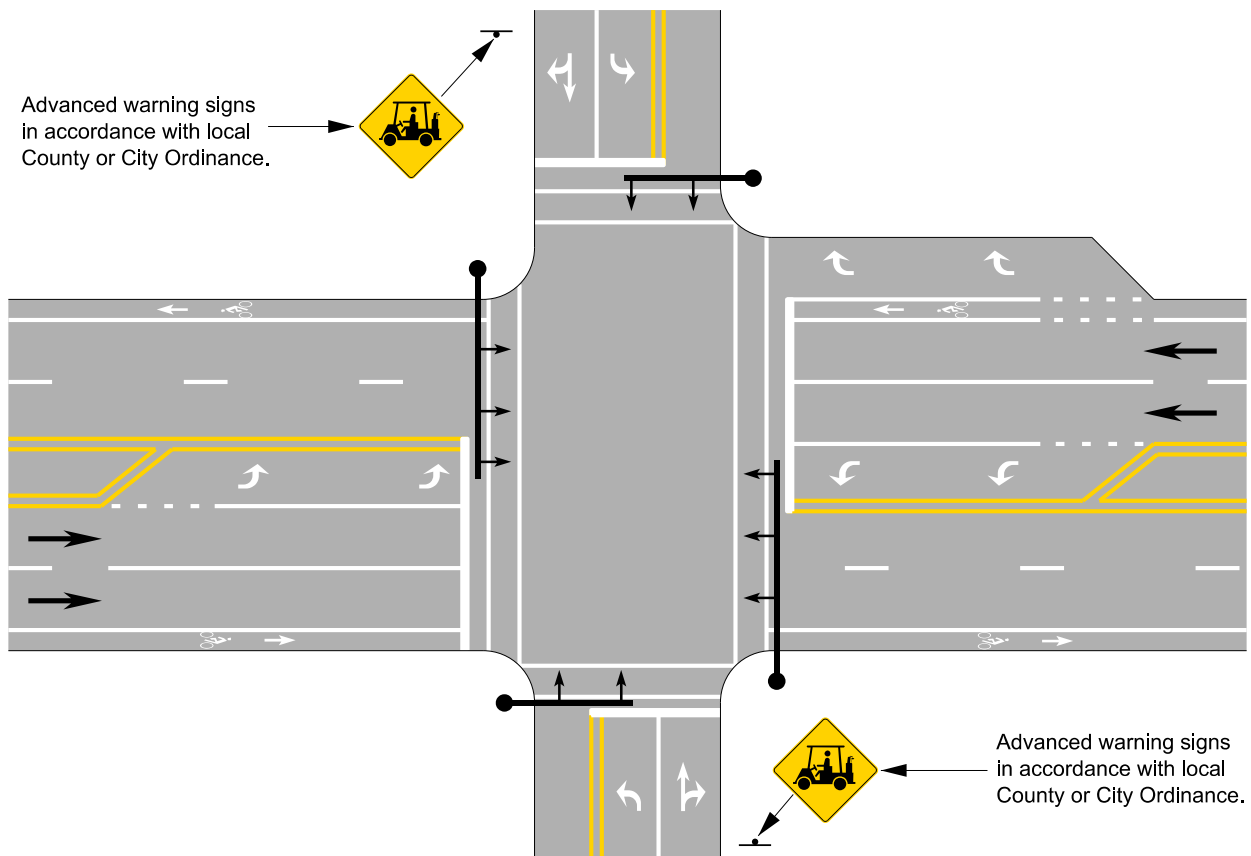

### 5.1.6 OPERATION OF GOLF CARTS ON SIDEWALKS

- (1) Under [Title 23 of United States Code, Section 217](#), existing and proposed non-motorized trails and pedestrian walkways using Federal transportation funds do not permit motorized use, including golf cars or golf carts. However, the legislation authorizes exceptions and the Federal Highway Administration (FHWA) has developed framework for an exception process.

- (2) **Safety and Operational Recommendations:** The following recommendations for the operation of golf carts on pedestrian sidewalks adjacent to a state road should be considered when authorizing such use by local government ordinance:
- (a) Access to State maintained sidewalks should be from county or city-maintained sidewalks adjacent to side streets intersecting with a state road. In-street golf cart operation onto State operated sidewalks via ADA curb ramps is not permitted.
  - (b) Crossing a state road from county or city-maintained streets or sidewalks to access State operated adjacent sidewalks is not recommended. If a local government submits a request for a golf cart crossing and seeks consultation for golf cart operation on a State operated sidewalk at the same location, the golf cart crossing will not be allowed.
  - (c) A minimum un-obstructed sidewalk width of 8 feet is required and separated from back of curb or edge of shoulder by at least 5 feet is recommended.
  - (d) A minimum width of 4 foot grassed or stabilized, relatively flat area should be provided beyond the outside edge of sidewalks for recovery or stalled golf carts. Sidewalks with existing adjacent drainage features or fencing should not be considered.
  - (e) Golf cart operation on State operated sidewalks should terminate at a connecting county or city-maintained sidewalk.
  - (f) State approved, Golf Cart On Sidewalk signs should be installed along State operated sidewalks as shown in **Figure 5.1-6**.

**Figure 5.1-6. Golf Cart Operation on Sidewalks**

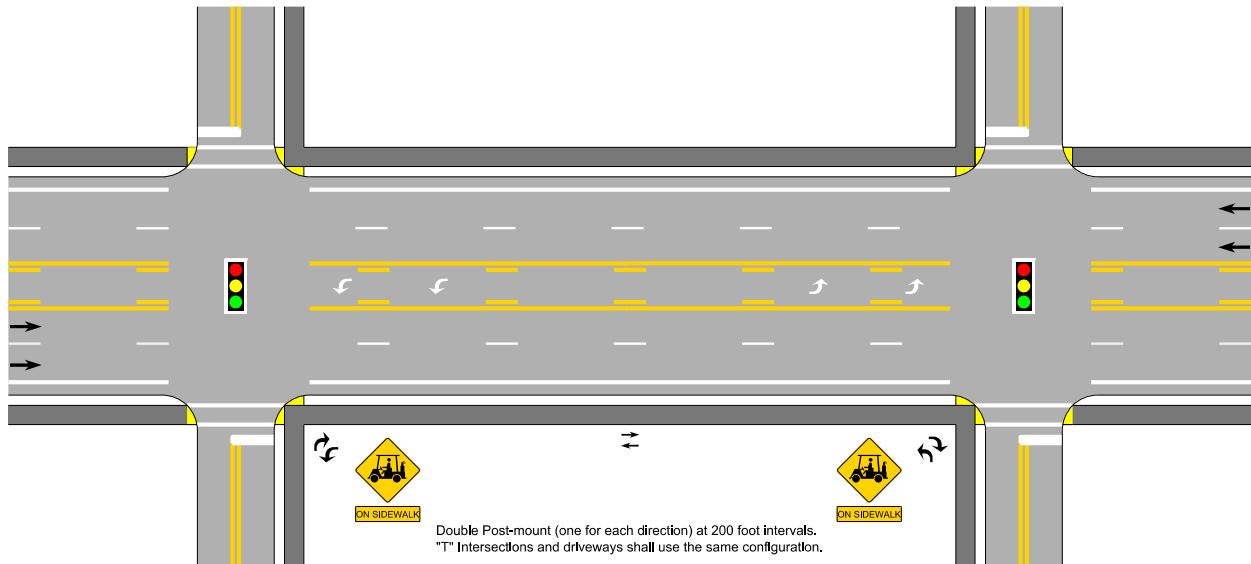

## Section 5.2

# TREATMENTS FOR PEDESTRIAN CROSSWALKS AT MIDBLOCK AND UNSIGNALIZED INTERSECTIONS

### 5.2.1 PURPOSE

This section establishes criteria and guidelines for the consistent installation and operation of pedestrian treatments at midblock and unsignalized intersections on the State Highway System. These treatments include marked pedestrian crosswalks, signs, traffic control devices, and other measures. Information on pedestrian crosswalks at roundabouts can be found in [FDOT Design Manual \(FDM\) 213](#).

### 5.2.2 GENERAL

- (1) A crosswalk facilitates pedestrian access and concentrates pedestrian crossing activity to a safe and predictable location. The intention of pedestrian treatments at midblock and unsignalized intersections is to improve pedestrian connectivity and reduce instances of pedestrians crossing at unpredictable locations. This can be achieved by reducing confusion and removing measurable risks to pedestrians and other road users.
- (2) Pedestrian crosswalks applied at midblock and unsignalized intersections may be a suitable treatment where documented pedestrian demand exists. For these locations, the distance to the nearest controlled intersection crossing would result in significant out-of-direction travel for pedestrians, increasing the risk for unexpected crossings and crashes.
- (3) Adding supplemental signage can improve safety and compliance in locations where a marked pedestrian crosswalk has been installed, including locations with or without traffic control devices. Other crosswalk design treatments, including refuge islands, curb extensions, lighting, and raised crosswalks, could also be considered to support pedestrian visibility and safety. **Figure 5.2-13** illustrates the combined use of many of these treatments.
- (4) Marked crosswalks and pedestrian treatments that are well located and thoughtfully designed can serve as a mechanism for improving pedestrian connections, community walkability, and pedestrian safety. However, they are not suitable for all locations. Suitability can be determined by careful evaluation regarding expected levels of pedestrian crossing demand, safety characteristics of the crossing location, and design considerations for the crossing control type.

## 5.2.3 DEFINITIONS

**Alternative Pedestrian Crossing Location.** Any controlled location with a STOP sign, traffic signal, or a grade-separated pedestrian bridge or tunnel that accommodates pedestrian movement across the subject roadway.

**Average Day.** A day representing traffic volumes normally and repeatedly found at a specific location. Weekdays having volumes influenced by employment or weekend days having volumes influenced by entertainment or recreation represent two types of an Average Day.

**Context Classification.** Description of the land use and transportation context where a roadway is found. Roadways are designed to match the characteristics and demands defined by the appropriate Context Classification. See [FDM 200](#) for additional information.

**Controlled Approach.** All lanes of traffic moving toward an intersection or a midblock location from one direction (including any adjacent parking lane) that are controlled by a sign, signal, marking, or other devices.

**In-Roadway Lights.** Special types of highway traffic control devices installed in the roadway surface to warn road users that they are approaching a condition on or adjacent to the roadway that might not be readily apparent and might require the road users to slow down and/or come to a stop.

**Marked Crosswalk.** Any portion of a roadway segment, including an intersection or midblock distinctly indicated as a pedestrian crossing by pavement marking lines on the surface which might be supplemented by contrasting pavement structure, style, or color. Marked crosswalks serve to provide guidance, define and delineate crossing paths, define intersections, and designate a stopping location when motorists are required to stop in the absence of a stop line.

**Midblock Crossing.** Any location where a marked crosswalk (signalized or unsignalized) is proposed or already exists between intersections.

**Midblock Pedestrian Signal (MPS).** An MPS is a hybrid between a Midblock Traffic Control Signal and a Pedestrian Hybrid Beacon and it is currently an ***MUTCD Request to Experiment (RTE)***. It is a highway traffic signal in which traffic is alternately directed to stop, then a flashing RED indication during the pedestrian clearing interval is activated to assist pedestrians crossing a street or highway at a marked crosswalk.

**Midblock Traffic Control Signal.** Any highway traffic signal by which traffic is alternately directed to stop and permitted to proceed at a midblock crosswalk.

**Passive Pedestrian Detection.** Automated pedestrian detection systems that can detect the presence and direction of pedestrians and activate the traffic control device without any required action by the pedestrian.

**Pedestrian Attractor.** A residential, commercial, office, recreational, or other land use that is expected to be an end destination for pedestrian trips.

**Pedestrian Generator.** A residential, commercial, office, transit, recreational or other land use that serves as the starting point for a pedestrian trip.

**Pedestrian Hybrid Beacon (PHB).** A special type of hybrid beacon used to warn and control traffic at an unsignalized location to assist pedestrians in crossing a street or highway at a marked crosswalk. It is also known as high-intensity activated crosswalk (HAWK).

**Rectangular Rapid Flashing Beacon (RRFB).** A traffic control device consisting of two rapidly and alternately flashing rectangular yellow indications having LED array-based pulsing light sources that function as a warning beacon.

**Shared Use Path.** A multi-user path outside the traveled way and physically separated from motorized vehicular traffic by an open space or barrier and either within the highway right-of-way or within an independent alignment. Shared use paths are used by pedestrians (including skaters, users of manual and motorized wheelchairs, and joggers), bicyclists and other authorized motorized and non-motorized users.

**Two-Stage Pedestrian Crossing.** A marked crosswalk controlled by RRFB, PHB or midblock traffic signal that is designed to allow pedestrians to cross each half of the roadway independently, using a median refuge island for pedestrians to wait before completing the crossing. A two-stage pedestrian crossing may have a lesser impact on vehicle delay (compared to a single crossing) since the signal serves each direction independently while the median serves as a refuge area for pedestrians to wait prior to completing their crossing.

**Uncontrolled Approach.** All lanes of traffic moving toward an unsignalized intersection or a midblock location from one direction (including any adjacent parking lane) that are not controlled by any sign, signal, marking, or other control devices.

**Unsignalized intersection.** Any at-grade junction of two or more public roads at which a highway traffic signal does not control the right-of-way for motorists, bicyclists, and pedestrians.

**Unmarked Crosswalk.** The legal crossing area at an intersection connecting opposite sides of the roadway that does not have painted lines, words, or images.

## 5.2.4 PROCEDURE

The procedures below are applicable for all crosswalks at midblock and unsignalized intersections.

- (1) The appropriate [District Traffic Operations Office](#) handles all submitted requests for evaluation of marked crosswalks or other treatments at a midblock or unsignalized intersection (including driveways).
- (2) Special emphasis crosswalk markings and advance warning signs shall be installed for all midblock. This will also apply to all uncontrolled approaches with crosswalks.
- (3) Additional treatments, such as pavement markings, signs, signals or other countermeasures, may be installed when meeting the criteria listed in **TEM 5.2.5**.
- (4) A study or warrant analysis shall be required for the use of midblock traffic control signals or PHBs for existing marked crosswalks at midblock or unsignalized intersections. Refer to **TEM 5.2.5** for more detailed guidance.
- (5) For new marked crosswalks, an engineering study is required in accordance with **TEM 5.2.6**. The engineering study shall include the pedestrian-vehicle crash history. All proposed crosswalk treatments shall meet the criteria listed in **TEM 5.2.5**.
- (6) For new marked crosswalks, the following minimum safety considerations should be evaluated:
  - (a) Adequate stopping sight distance at marked crosswalks
  - (b) Presence of crosswalk illumination
  - (c) For a roadway with five (5) or more lanes, a refuge island or raised median to facilitate a two-stage crossing
  - (d) Appropriate bus stop location to minimize conflicts with transit vehiclesFor further safety improvements, see **TEM 5.2.7**.
- (7) Prior to the approval of a new marked crosswalk, or treatments to an existing marked crosswalk, the [District Traffic Operations Office](#) should coordinate with the local maintaining agency to determine the eligibility of adding the newly installed treatments to the maintenance and compensation agreement.
- (8) Any marked crosswalk or other treatment proposed for a midblock or unsignalized intersection on the State Highway System shall be reviewed and approved by the [DTOE](#) prior to installation.

## 5.2.5 SELECTION CRITERIA

### 5.2.5.1 Criteria for Marked Crosswalk

Placement of marked crosswalks at midblock and uncontrolled approaches should be based upon a strategic plan and requires an engineering study to validate the need. Marked crosswalks should not be used indiscriminately at midblock and unsignalized intersections. An engineering study (see **TEM 5.2.6**) shall include, but not be limited to, pedestrian-vehicle crash history, proximity to significant generators and attractors, minimum levels of pedestrian demand, and minimum location characteristics. Listed below are the criteria for placement of marked crosswalks:

- (1) Proximity to significant generators and attractors
  - (a) Any midblock or unsignalized intersection under consideration for a marked crosswalk should have either of the following characteristics:
    - A well-defined spatial pattern of pedestrian generators, attractors, and flow (across a roadway) between them; or
    - A well-defined pattern of existing pedestrian crossings.
  - (b) Identification of pedestrian generators and attractors shall be documented in an engineering study to illustrate potential pedestrian routes in relation to any proposed marked crosswalk locations, as described in **TEM 5.2.6**.
- (2) Recommended Levels of Pedestrian Demand
  - (a) Pedestrian volume data for an average day shall be collected with the methods described in **TEM 5.2.6**.
  - (b) The following threshold should be considered for a new marked crosswalk:
    - 20 or more pedestrians during a single hour (any four consecutive 15-minute periods) of an average day.
  - (c) Pedestrian volume demand data is not needed for the following conditions:
    - Pedestrian crosswalks within a school zone
    - Pedestrian crosswalks under the following Context Classifications:
      - C2T Rural Town Context Classification zone
      - C3C Suburban Commercial Context Classification zone

- C4 Urban General Context Classification zone
  - C5 Urban Center Context Classification zone
  - C6 Urban Core Context Classification zone
- (d) Crosswalks threshold at midblock or unsignalized intersection connecting a **SHARED USE PATH**
- To promote the use of shared use paths and reduce the occurrence of multiple roadway crossings, crossing locations connecting to a shared use path may use a 50 percent reduction to the recommended pedestrian threshold in **TEM 5.2.5.1-(2)b**.
  - Check with local strategic plan when determining the location for installing these types of marked crosswalks.
- (e) Nature-based trail crossings
- See **TEM 2.33** for additional information on nature-based trail crossings.
  - Before a new nature-based trail crossing is approved, the **DTOE** should evaluate whether it's appropriate to install the trail crossing on the State Highway System (SHS).
- (3) Minimum Location Characteristics
- (a) A minimum vehicular volume of 2,000 Average Daily Traffic (ADT) along the roadway segment.
- (b) Minimum distance to nearest alternative intersection or crossing location
- The minimum distance to nearest alternative intersection or crossing location is 300 feet per the **FDM 222**.
  - A proposed crossing location that falls between 100 and 300 feet from an alternative existing crossing may be considered if it is more practical for pedestrian use; this justification must be documented in the engineering study.
- (c) Adjacent signalized intersection
- The proposed location must be outside the influence area of adjacent signalized intersections, including the limits of the auxiliary turn lanes.

## 5.2.5.2 Criteria for Beacons and Signals

### (1) Yellow Flashing Beacons and RRFB

- (a) Use of flashing beacons shall be limited to the roadways with the following conditions:
- A marked special emphasis crosswalk
  - Four (4) or fewer through lanes (both directions)
  - Posted speed limit of 35 MPH or less
- (b) For locations with five (5) lanes (4-through lanes with a Two-Way Left Turn Lane), a refuge island or raised median may be installed at the center of the roadway to create a two-stage crossing.
- (c) Overhead flashing beacons and RRFB are preferred to be used for locations with four (4) lanes divided or five (5) lane roadways with a median refuge island.
- (d) For locations that do not meet the criteria above, a variation must be submitted to the [State Traffic Engineering and Operations Office](#) for review and approval. The variation shall include the following:
- AADT
  - Sight distance
  - Speed data
  - Supplemental information including location description and observations
  - Crash data

### (2) Pedestrian Hybrid Beacon (PHB)

- (a) A PHB should not be installed at an intersection or a driveway. A minimum distance of 100 feet from side streets or driveways controlled by stop or yield signs should be maintained when installing a PHB.
- (b) For locations less than 100 feet from the side streets or driveways controlled by a stop sign, the engineer of record shall address additional treatments to reduce conflict risk between pedestrians and vehicles. These additional treatments may include blank-out signs, static signs, in-

roadway lights, **R1-6a sign**, **R10-6 (STOP HERE ON RED) sign**, or other treatments to inform drivers of the PHB.

- (c) The following conditions may be considered for the installation of a PHB.
- When a midblock traffic control signal is not justified under [Chapter 4C of the MUTCD](#) signal warrants and when gaps in traffic are not adequate to permit pedestrians to cross
  - When the speed of vehicles approaching the location on the major street is too high to permit pedestrians to cross
  - When pedestrian delay is excessive
- (d) PHBs should meet [Chapter 4F of the MUTCD](#) PHB volume guidance. This guidance is summarized in **Figure 5.2-1** and **Figure 5.2-2**.
- (e) In an urban corridor under context classification C4, C5, and C6 with a site location that warrants a PHB in accordance to the above criteria, the PHB may be substituted with a midblock traffic control signal using [Warrant 8 of the MUTCD, Roadway Network](#).

### (3) Midblock Traffic Control Signal

- (a) Traffic control signals at midblock crosswalks should meet a minimum distance of 300 feet from side streets or driveways controlled by a stop or yield sign.
- (b) For midblock crosswalks that are greater than 300 feet from the nearest signalized intersection, its distance to adjacent signals and availability of adequate gaps for pedestrian crossing shall also be considered to determine whether the signal is needed for safe pedestrian crossing.
- (c) Traffic Control Signals at midblock crosswalks shall meet [Warrant 4 of the MUTCD, Pedestrian Volume](#). **Figure 5.2-1** and **Figure 5.2-2** summarize this warrant. The minimum pedestrian volume threshold under Warrant 4 may be reduced for the following conditions:
- When the 15th percentile crossing speed is less than 3.5 feet per second, the pedestrian volume that crosses the major street can be reduced as much as 50 percent.
  - When the 85th percentile speed on the major street exceeds 35 mph or when the area of the midblock crossing is within the built-up area of an isolated community having a population of less than 10,000, the pedestrian volume that crosses the major street can be reduced by 30 percent.

- (d) Combining both pedestrian volume reductions of 30 and 50 percent is allowed when it meets the criteria listed in (c) above.
- (e) Information on requirements for traffic control signal at intersections can be found in **TEM 3.3**.

**Figure 5.2-1. Guidelines for the Installation of Pedestrian Treatments on Low-Speed Roadways**

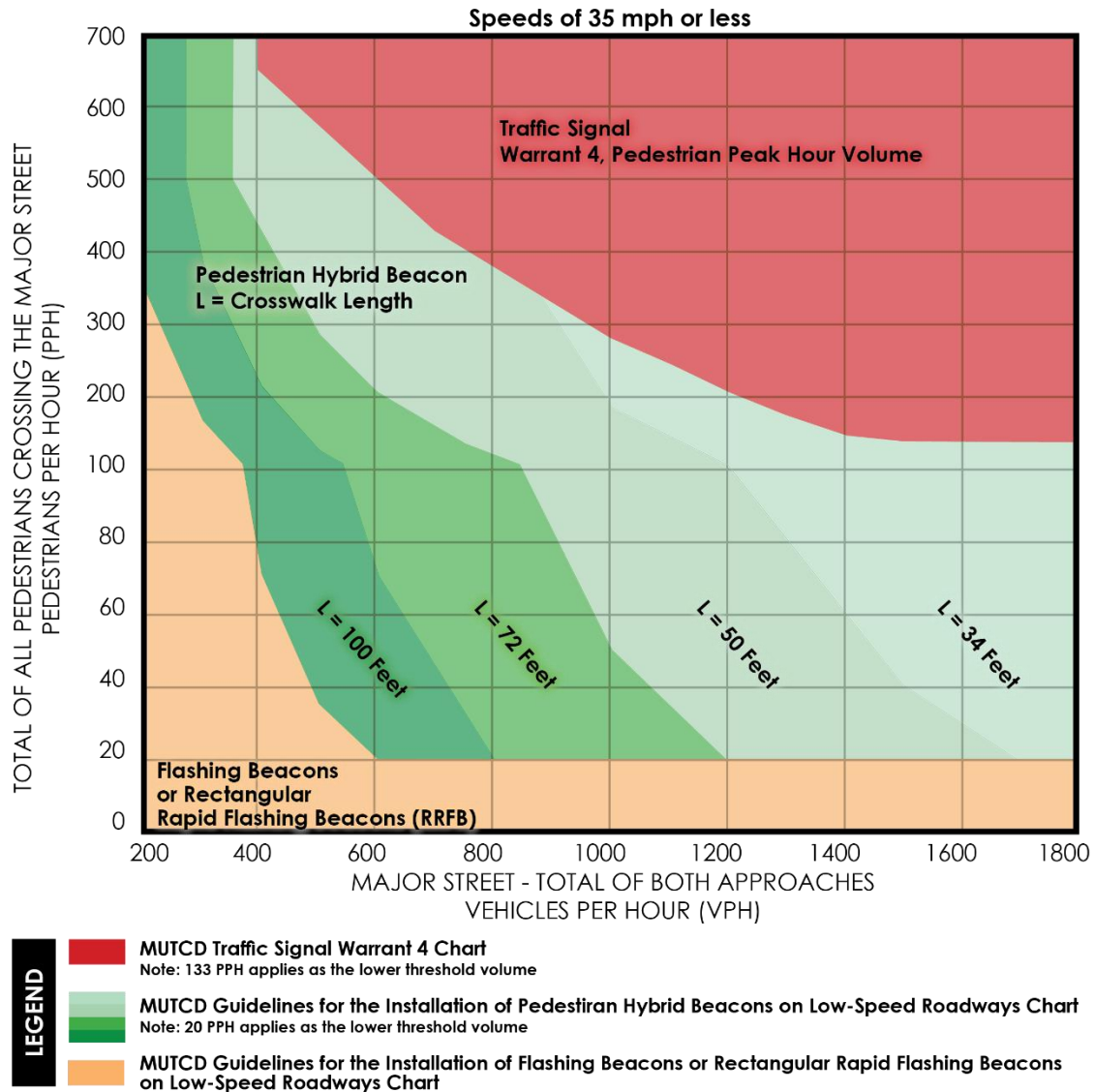

**Figure 5.2-2. Guidelines for the Installation of Pedestrian Treatments on High-Speed Roadways**

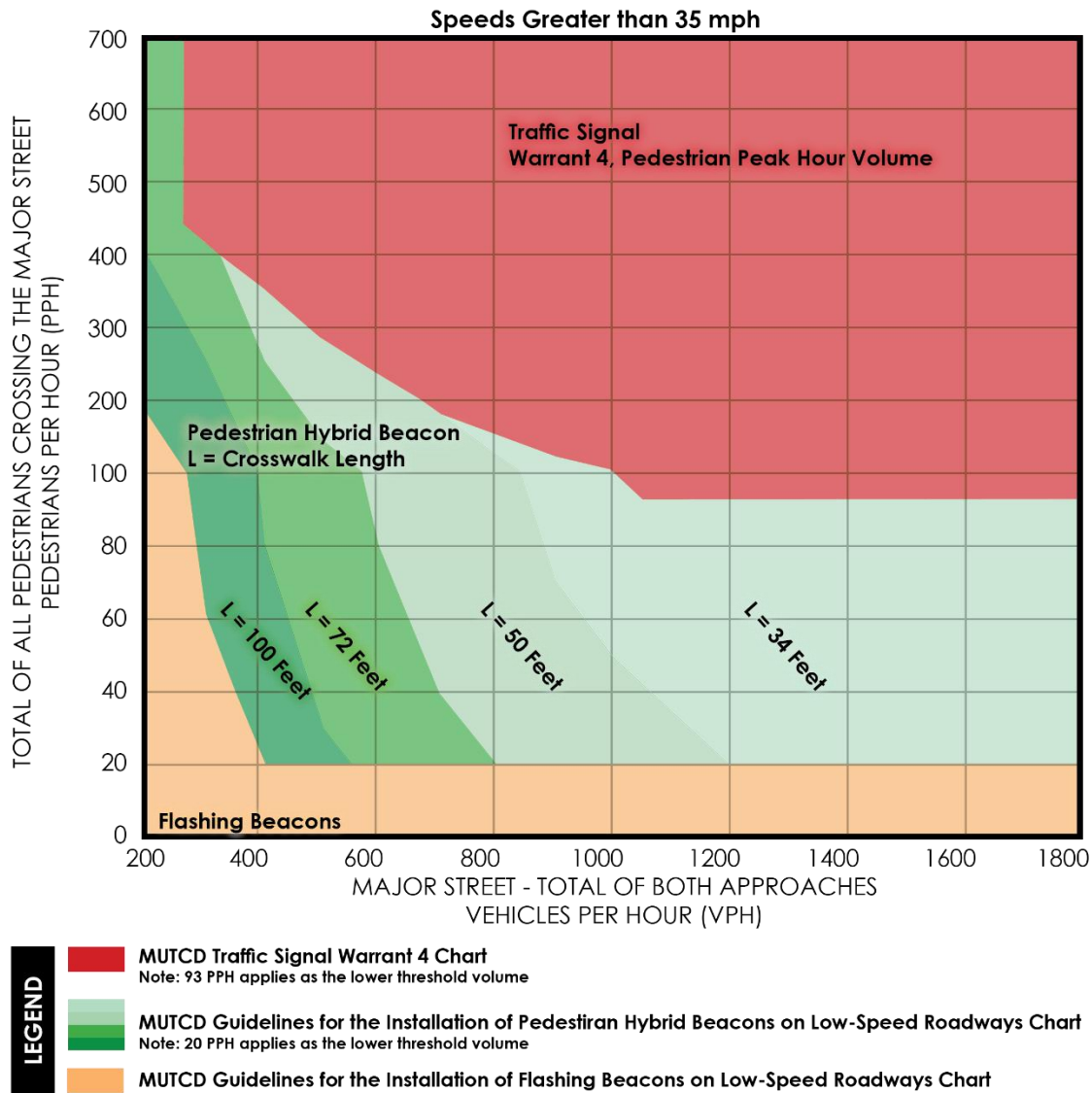

## 5.2.6 ENGINEERING STUDY

- (1) An engineering study shall be conducted before the installation of a marked pedestrian crosswalk and/or treatments at a midblock crosswalk location or unsignalized intersection. Criteria for selecting the specific treatment(s) shall include, but not be limited to, pedestrian and vehicular volumes, roadway characteristics, and other environmental factors as documented in the study.
- (2) The engineering study should include the following information:

- (a) Field data to demonstrate the need for a marked crosswalk based upon minimum pedestrian volumes (except as described in **TEM 5.2.5.1** and availability of any alternative crossing locations that satisfy the criteria described in **TEM 5.2.5**).
- Data collection should be based upon pedestrian volumes observed crossing the roadway outside a crosswalk at or in the vicinity of the proposed location or at an adjacent (nearby) intersection. If applicable, a cyclist can be counted as a pedestrian.
  - The [Department's Manual on Uniform Traffic Studies \(MUTS\)](#) provides additional information on obtaining pedestrian group size and vehicle gap size field data for use in making assessments of opportunities for safe crossings at midblock and unsignalized intersections.
- (b) Field data to estimate individual pedestrian walking speeds, pedestrian speed cumulative curve, and the 15<sup>th</sup> percentile pedestrian crossing speed. The [Chapter 9 of the Department's Manual on Uniform Traffic Studies \(MUTS\)](#) provides additional information on the procedure and method for calculating the parameters of pedestrian walking speed.
- (c) Potential links between pedestrian generators and attractors. Generators and attractors should be identified over an aerial photograph to illustrate potential pedestrian routes in relation to any proposed marked crosswalk location. This information is required for establishing the proposed crossing location or to confirm existing pedestrian crossing patterns.
- (d) All safety considerations as described in **TEM 5.2.4** with respect to stopping sight distances, illumination levels, and proximity to intersection conflict areas.
- (e) Proposed crossing location and corresponding signing, marking, and signal treatments as follows:
- A schematic layout should be provided over aerial photography or survey to show locations of signs, markings, and other treatments in proximity to existing traffic control devices.
  - Treatments are dependent upon the site context, vehicle operating speeds, roadway cross-section, pedestrian volumes, and other variables. Treatments may include consideration of traffic signals or other warning devices to enhance driver yielding behavior. Other treatments such as median refuge areas, curb extensions, raised crosswalks, and supplemental signing and markings may also be applicable at some locations to support reduced crossing distance

and enhanced pedestrian visibility. See **TEM 5.2.7** for discussion of treatment options and guidance on treatment selection.

- (f) Latest three years of pedestrian-vehicle crash history within the vicinity of the proposed crosswalk. Document the number and nature of pedestrian-vehicle conflicts based on field observations.
  - (g) Transit route data and the location of transit stops within the vicinity of the proposed crosswalk.
- (3) Alternative analysis can be conducted at adjacent intersection and midblock locations through the procedure described in the [Department's Manual on Intersection Control Evaluation](#). Intersection and midblock crosswalk's needs might be identified and resolved by considering alternative control strategies that meet the project's purpose and need. The [Department's Manual on Intersection Control Evaluation](#) provides guidelines on these alternative designs.

## 5.2.7 TREATMENT OPTIONS

### 5.2.7.1 Pavement Markings

#### (1) Marked Pedestrian Crosswalk

##### (a) Special Emphasis Crosswalk

Marked crosswalks at unsignalized intersections (uncontrolled approach) and midblock crossings require a special emphasis crosswalk. Follow the procedures identified in **TEM 5.2.4** prior to installation.

##### (b) Standard Crosswalk

At an unsignalized intersection-controlled approach, the crosswalk marking must comply with [FDM 230](#) design criteria. An engineering study is not required for the installation of standard crosswalks.

#### (2) PEDESTRIAN CROSSING WARNING Sign (**W11-2**) Pavement Markings

- (a) The use of **W11-2** pavement markings may be used to supplement existing signage at marked pedestrian crossings when high vehicular volumes and speeds are documented in an engineering study. The **W11-2** pavement markings shall be reviewed and approved by the [DIOE](#) prior to installation. The use of **W11-2** pavement markings as a safety countermeasure is recommended and should be installed if any of the following conditions apply:

- Multi-lane roadway (45 mph or greater)

- Rural two-lane roadway (50 mph or greater)
  - Crosswalks have restricted sight distance due to obstructions such as trees or parked vehicles
  - There is a documented history of non-compliant driver yielding to pedestrians behavior
- (b) When installing at midblock or unsignalized intersections, the **W11-2** pavement markings shall be applied as follows (see **Figure 5.2-3** and **Figure 5.2-4** for additional information):
- Centered in the travel lane(s) on the approach to the crosswalk and in alignment with adjacent lanes when used on multi-lane approaches
  - The **W11-2** pavement marking shall not be intermixed with other pavement markings
- (c) The **W11-2** pavement markings installation shall be coordinated with the District Maintenance Office.

**Figure 5.2-3. PEDESTRIAN CROSSING WARNING Sign (W11-2) Pavement Marking**



**Figure 5.2-4. PEDESTRIAN CROSSING WARNING Sign (W11-2) Pavement Marking Details**

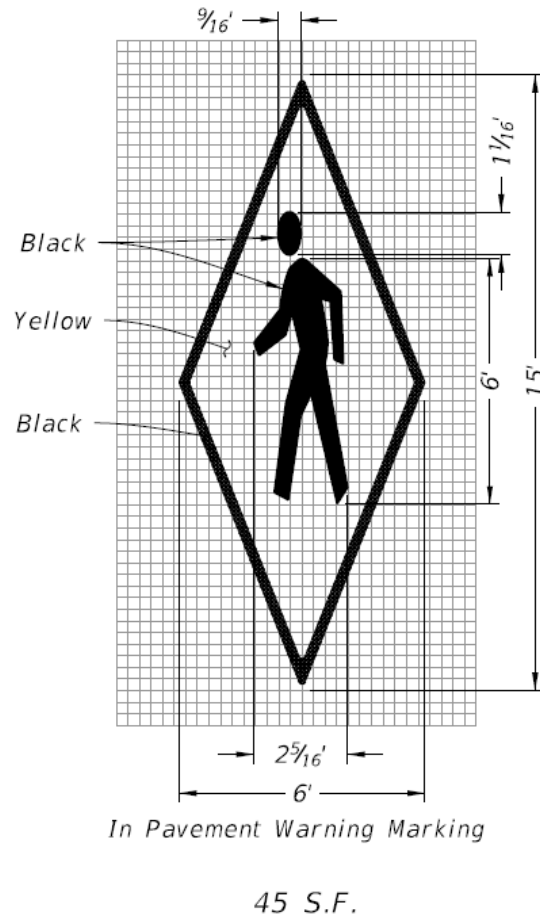

### (3) Pavement Word Markings

Information on the use of Pavement Word Markings can be found in **TEM 4.2**.

## 5.2.7.2 Signs

### (1) General

- (a) The following signs may be installed at midblock crosswalks and unsignalized intersections to improve non-compliant driver yielding and stopping behavior to pedestrians. Sign placement details can be found in the [FDM 230](#).
- (b) To enhance sign conspicuity, highlighted signs and flashing beacons may be installed in accordance with [Section 2A.15 of the MUTCD](#).

### (2) STOP HERE FOR PEDESTRIANS Sign (R1-5b and R1-5c)

- (a) For additional emphasis, a stop line may be installed with the STOP HERE FOR PEDESTRIANS (**R1-5b** and **R1-5c**) sign in accordance with [Section 2B.11 of the MUTCD](#).
- (b) If stop lines are used, they shall be placed 40 feet in advance of the marked crosswalk.
- (c) When the STOP HERE FOR PEDESTRIANS sign is installed, parking shall be prohibited in the area between the stop line and the marked crosswalk. Use a solid lane line between the stop line and crosswalk.
- (d) The **R1-5b** and **R1-5c** signs shall be used with the advanced warning **W11-2** and **W16-7P** signs.
- (e) The **R1-5b** and **R1-5c** signs shall not be used in combination with the traffic signal or PHB.
- (f) The **R1-5b** and **R1-5c** sign may be used at locations where there is non-compliant stopping for pedestrians at an existing mid-block crosswalk, as follows:
  - One sign in each direction
  - Within 100 feet in advance of the crosswalk
  - Shall not interfere with other required signs

**Figure 5.2-5. Pedestrian Crossing Signs  
(R1-5b and W11-2 with an RRFB)**

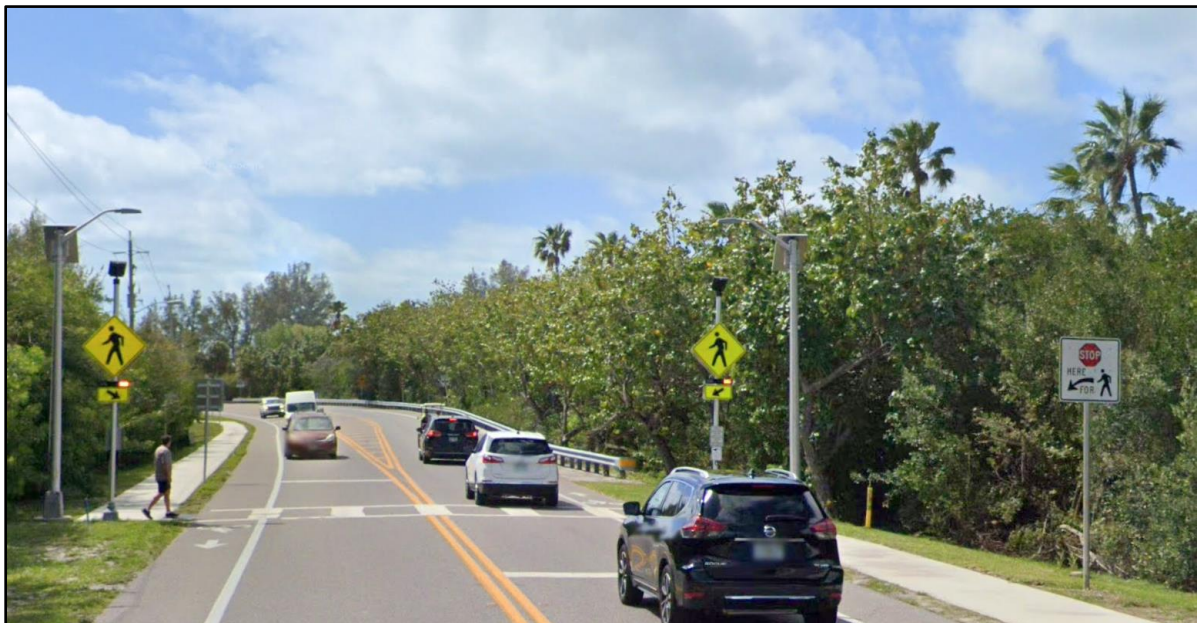

**(3) TURNING VEHICLES STOP FOR PEDESTRIANS sign (R10-15a)**

**TEM 2.44** provides guidance for use of the TURNING VEHICLES STOP FOR PEDESTRIANS sign (**R10-15a**) at locations other than midblock crosswalks.

**(4) PEDESTRIAN CROSSING Signs**

- (a)** A PEDESTRIAN CROSSING (**W11-2**) warning sign with supplemental AHEAD plaque (**W16-9P**) shall be used in combination with the **R1-5b** or **R1-5c** sign.
- (b)** A school sign (**S1-1**) with supplemental diagonal downward pointing arrow (**W16-7P**) may be used to advise road users that they are approaching a crosswalk in close proximity to a school.
- (c)** The combined bicycle/pedestrian sign (**W11-15**) may be used where both bicyclists and pedestrians might be crossing the roadway. A TRAIL X-ING (**W11-15P**) supplemental plaque may be mounted below the **W11-15** sign.

**(5) In-Street Sign (R1-6a)**

- (a)** In-street signs (**R1-6a**) are useful on low-speed roadways to remind road users of laws regarding right-of-way at a midblock or unsignalized pedestrian crosswalk. In-street signs (**R1-6a**) can only be implemented in roadways with four (4) or fewer through lanes (both directions) and with a posted speed limit of 35 MPH or less.
- (b)** Coordination with the District Maintenance Office is required prior to approving the use of the in-street sign (**R1-6a**).
- (c)** If used, the in-street signs (**R1-6a**) shall be placed at one of the following locations:
  - In the roadway at the marked crosswalk location on the center line,
  - In the case of a one-way roadway application, on a lane line, or
  - On a median island as allowed by [Section 2B.12 of the MUTCD](#).

**Figure 5.2-6. Pedestrian Crossing Signs  
(R1-6a and W11-2)**



- (d) [Standard Plans, Index 700-102-1](#) provides design details for the fabrication of in-street signs (**R1-6a**).
- (e) The in-street sign (**R1-6a**) shall not be post-mounted on the left-hand or right-hand side of the roadway.
- (f) The use of in-street signs (**R1-6a**) on lane lines may be substituted with tubular markers to reduce the maintenance and replacement cost due to periodic impacts from vehicular traffic. When the tubular markers are used to supplement an **R1-6** series sign that is either on the center line, lane line, or median island, they should not be used on the same pavement marking line where the **R1-6** Series sign is installed. If used, the tubular marker shall be the same color as the pavement marking that they supplement, in accordance with [Section 3H.01 of the MUTCD](#). For further guidance on tubular marker substitution, please review **TEM 5.2.7.2(5)(h)**.
- (g) Tubular Marker Gateway Treatment
  - To provide additional emphasis for the pedestrian crossing and to provide a channelizing and potentially calming effect on vehicle traffic, the in-street signs (**R1-6a**) may be used with one or more supplemental tubular markers on the lane lines or edge lines at a mid-block pedestrian crossing.

- The use of supplemental tubular marker for gateway treatment is compliant with the [MUTCD](#). See FHWA Official Ruling [3\(09\)-61 \(I\) – Channelizing Devices at Mid-Block Pedestrian Crossings in Conjunction with In-Street Pedestrian Crossing \(R1-6 Series\) Signs](#) issued on August 3, 2020, with guidance and illustrations.

**Figure 5.2-7. Gateway Treatment with R1-6a and Tubular Marker**

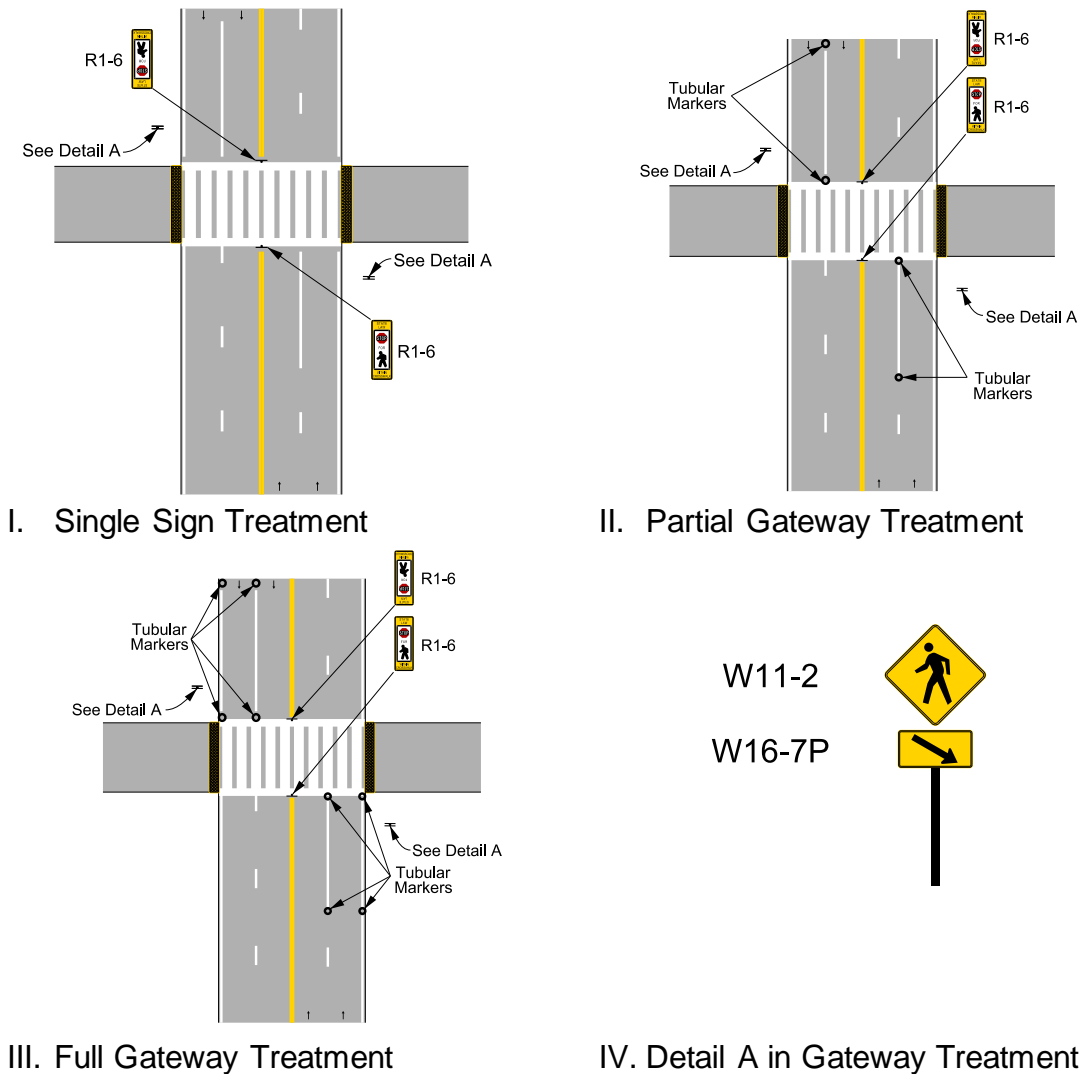

**(6) Portable Changeable Message Sign (PCMS)**

To inform the traveling public of a new traffic control pattern, a PCMS shall be required for all new RRFB, PHB, flashing yellow beacon, and midblock traffic control signals in accordance with the following criteria.

- (a) The PCMS shall display the following safety message:

- NEW SIGNAL XX/XX
  - PREPARED TO STOP
- (b) District shall notify local law enforcement and local agency two weeks before the new traffic control device is installed.
- (c) The PCMS shall be installed two weeks prior and remain in place for a minimum of one week after the installation of traffic control devices mentioned above.

### 5.2.7.3 Beacons (Signal Warrant Analysis Not Required)

#### (1) General

- (a) For locations not warranted for traffic control signals or PHBs, alternative pedestrian-actuated warning devices presented in this section may be considered to provide additional emphasis on the marked crosswalk and of the presence of pedestrians. For guidance on supplemental warning device options that are exempt from warrants, see **TEM 5.2.4** for details.
- (b) Additional treatments not included in this section may also be appropriate depending upon the individual site characteristics. Engineering judgment should guide decisions about which additional treatment options to include, if any.

#### (2) Rectangular Rapid Flashing Beacons (RRFB)

- (a) The FHWA issued [Interim Approval 21, Rectangular Rapid Flashing Beacons at Crosswalks \(IA-21\)](#) on March 20, 2018, which specifies the intended use and design requirements for RRFB devices.
- (b) FDOT has received FHWA approval to install RRFBs on the State Highway System. Local agencies must receive FHWA approval prior to installing RRFBs on their local roads.
- (c) The rectangular beacons are provided in pairs below the PEDESTRIAN CROSSING warning sign (**W11-2**) (and above the diagonal downward arrow (**W16-7P**) plaque for post-mounted RRFB) and operate in a flash pattern upon activation by the pedestrian. For school zone or trail crossings, school sign (**S1-1**) or combined bicycle/pedestrian sign (**W11-15**) may be placed alternatively above the rectangular beacons instead of the pedestrian crossing sign (**W11-2**). Detailed conditions of use, including sign/beacon assembly, dimensions, placement, and flashing rates are provided in [Interim Approval \(IA-21\)](#). Refer to the following FDOT policy for more guidance on RRFB implementation:

- [Standard Plans, Index 654-001](#)
  - [FDM 327](#)
  - [Standard Specifications, Section 700](#)
  - [Standard Specifications, Section 654](#) requires that RRFBs shall include an instruction sign with the following 3-line legend PUSH BUTTON FOR WARNING LIGHTS / WAIT FOR TRAFFIC TO STOP / CROSS WITH CAUTION (**FTP-68C-21**) sign mounted adjacent to or integral with the pedestrian push button device.
- (d) As of January 1, 2021, all new RRFB installations shall include an audible warning message that states “WAIT FOR TRAFFIC TO STOP THEN CROSS WITH CAUTION” when activated. An example of the RRFB treatment is shown in **Figure 5.2-8**.

**Figure 5.2-8. Rectangular Rapid Flashing Beacons**



**(3) Flashing Yellow Beacons**

- (a) For locations where traffic signals are not warranted, additional emphasis on the crossing location can be provided when using flashing yellow beacons to supplement the appropriately marked crossing warning or regulatory signs. These devices are still allowable in the [MUTCD](#), although

newer devices such as RRFBs have increased in popularity.

- (b) When used, flashing yellow beacons shall meet the requirements of [Chapter 4L of the MUTCD](#).
- (c) [Standard Plans, Index 700-120](#) provides design details for the installation of flashing beacons.
- (d) Configuration of beacons is either overhead or side-mounted; however, the preferred configuration is a side post-mounting to avoid drivers confusing the beacons for a flashing traffic signal.
  - When post-mounted, the recommendation is to have a configuration of two vertically aligned beacons. These beacons should operate in an alternating flash pattern.
  - When overhead mounted, flashing yellow beacons should feature an internally illuminated Overhead Pedestrian Crossing sign (**R1-9a**) in conjunction with the beacons, which is continuously lit at night.

#### (4) In-Roadway Lights

- (a) [Chapter 4N of the MUTCD](#) provides detailed guidance on the installation of in-roadway lights.
- (b) Coordination with the District Maintenance Office is required prior to approving the use of the in-roadway lights.
- (c) In-roadway lights are installed in the roadway surface to warn road users that they are approaching a condition on or adjacent to the roadway that might not be readily apparent and might require the road users to slow down and/or come to a stop. This includes marked midblock crosswalks and marked crosswalks on uncontrolled approaches.
- (d) In-roadway lights may be installed at certain marked crosswalks, based on an engineering study or engineering judgment, to provide additional warning to road users.
- (e) When used, in-roadway lights shall be flashed and shall not be steadily illuminated.
- (f) The installation of in-roadway lights in conjunction with overhead or LED roadside highlighted signs or flashing yellow beacons is allowed as long as the flashing rates are identical and flash in unison. Exercising engineering judgment is of great importance.
- (g) In locations where overhead lighting has been omitted by the engineer of

record, in-roadway lights shall be considered.

(h) In-roadway lights shall:

- Be installed only at marked crosswalks with applicable warning signs;
- Be installed along both sides of the crosswalk and shall span its entire length; and
- Not be used at crosswalks controlled by YIELD signs, STOP signs, or traffic control signals.

(i) If pedestrian push buttons are used to actuate the in-roadway lights, a PUSH BUTTON TO TURN ON WARNING LIGHTS (with push-button symbol) (**R10-25** or **FTP-68C-21**) sign shall be mounted adjacent to or integral with each pedestrian push button.

#### 5.2.7.4 Beacons and Signals (Warrant Analysis Required)

(1) Pedestrian Hybrid Beacon (PHB)

- (a) A possible alternative to the traffic signal is a PHB. If used, PHBs shall be used in conjunction with signs and pavement markings to warn and control traffic at locations where pedestrians enter or cross a street or highway. An example of the PHB treatment is shown in **Figure 5.2-9**.
- (b) A PHB shall only be installed at a midblock crosswalk. [Chapter 4F of the MUTCD](#) provides guidance and criteria for PHB installation.
- (c) For six-lane roadways or crossing distances exceeding 80 feet, a two-stage pedestrian crossing with a median refuge island should be considered where a warranted PHB will control the proposed marked crossing.
- (d) PHB treatments shall include the CROSSWALK, STOP ON RED, PROCEED ON FLASHING RED WHEN CLEAR (**R10-23a**) sign. The **R10-23a** replaces the existing **MUTCD R10-23** sign per the [FHWA Interpretation Letter 4\(09\)-61\(I\)](#).

**Figure 5.2-9. Pedestrian Hybrid Beacons**



**(2) Midblock Traffic Control Signal**

- (a) When pedestrian volumes are of a sufficient level to meet the [Signal Warrant 4 of the MUTCD](#), a midblock traffic control signal may be installed to serve this demand in accordance with [Section 4C.05 of the MUTCD](#) for the following locations:
- High pedestrian demand (provided an [MUTCD](#) signal warrant is satisfied) and the new pedestrian signal is compatible with the signal system along the arterial corridor.
  - Where signalized control is selected for the pedestrian crossing, additional coordination for the crossing location is recommended with the District Access Management Review Committee and the [DTOE](#).
- (b) For six-lane divided roadways or crossing distances exceeding 80 feet, a two-stage pedestrian crossing with a median refuge island should be considered where a warranted traffic control signal will control the proposed marked midblock crossing.
- (c) At locations where pedestrian compliance is of concern, feedback devices

may be installed with the traffic control signal button to provide pedestrians with confirmation of the call.

- (d) For locations where signal warrants are met, consideration may be given to providing a pedestrian bridge or tunnel to address safety and compliance issues that cannot be addressed by a traffic signal.
- (e) In some cases, a traffic control signal may not be needed at the study midblock location if adjacent coordinated traffic control signals consistently provide gaps of adequate length for pedestrians to cross the roadway. The [Department's Manual on Uniform Traffic Studies \(MUTS\)](#) provides additional guidance on conducting Pedestrian Group Size and Vehicle Gap Size studies.
- (f) Information on the use of accessible pedestrian signals can be found in **TEM 3.7**.
- (g) [Standard Plans, Index 653-001](#) provides details for installing midblock traffic control signals. An example of the midblock traffic control signal treatment is shown in **Figure 5.2-10**.

**Figure 5.2-10. Midblock Traffic Control Signal**



### 5.2.7.5 Other Treatments

Incorporation of the following treatments to improve visibility, support pedestrian travel, and increase awareness for pedestrians at crossings is worth consideration. Further information on the design criteria of these treatments is in the [FDM 222](#).

- (1) Pedestrian refuge islands or raised median
- (2) Curb extensions
- (3) Raised crosswalks (See *Figure 5.2-11*)

**Figure 5.2-11. Raised Pedestrian Crosswalk**



- (4) Speed reduction treatments (See [FDM 202](#))
- (5) Crosswalk illumination
  - (a) Crosswalk illumination shall be provided in accordance with [FDM 222 and 231](#).
  - (b) There may be locations such as environmental-sensitive areas or crosswalks serving facilities that are open only during daylight hours,

where lighting may be omitted. [DTOEs](#) shall approve this omission. In-roadway lighting shall be considered at these locations.

(6) Passive pedestrian detection

(a) In addition to traditional active pedestrian detection (push button), passive pedestrian detection may be used to supplement and improve pedestrian detection for signals, RRFBs, PHBs, and warning beacons.

- Passive pedestrian detection should be used when there is a documented observation of low usage of the active pedestrian detection (push button). This could be acquired by field review, demographics, or per request. Children/teenagers, school zone, aging roadway users, and other demographics should be considered when implementing passive pedestrian detection.
- When passive pedestrian detection is installed, adequate passing space around the waiting detection area on the sidewalk should be present
- Overhead lighting shall be provided to increase pedestrian visibility and detector accuracy.
- Detection zones should be adjusted after installation to cover the exact specified pedestrian waiting area.
- When using passive pedestrian detection, adequate installation height, detection distance, and position and angle of the detector should be ensured to recognize pedestrian features and detect the presence of pedestrians. If there are no existing poles or infrastructure at the implementation site, a supplemental pole or an extended arm from an existing pole should be considered and installed.
- When deploying a passive pedestrian detection system, two options will be encountered for the sidewalk locations as illustrated in **Figure 5.2-12**.
  - For the option in **Figure 5.2-12 a)**, a grassy shoulder/buffer is constructed between the sidewalk and the road. The area leading towards the crosswalk can be used as the detection zone for the system, providing a well-established and clear area for detection. This option is preferable for deploying passive pedestrian detection.
  - For the option in **Figure 5.2-12 b)**, a sidewalk is constructed next to a curb without any buffer between them, which is

common in urban environments with limited right-of-way. The area that can be used for detection is smaller, and a pedestrian walking on the sidewalk turning into the crosswalk may not be detected in some cases. There may also be false detections with this design. The pedestrian “WALK” signal can be activated by pedestrians walking along the sidewalk but not turning to the crosswalk. This limitation must be considered when implementing passive pedestrian detection.

**Figure 5.2-12. Sidewalk Location Options for Passive Pedestrian Detection**

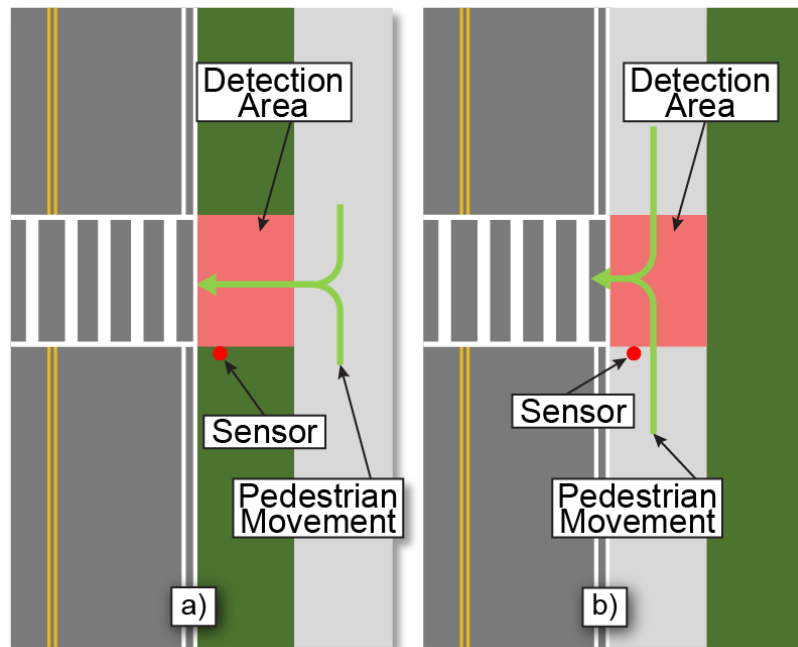

(b) For a shared-use path that crosses a state roadway, passive bicyclist detection may be added in addition to an active bicyclist detection (push button) to improve driver yielding behavior and cyclist safety. Consider the following guidance when installing passive bicyclist detection at midblock or unsignalized intersections.

- At unsignalized intersections and midblock that require bicyclists to be detected, passive bicyclist detection shall be considered.
- The passive bicyclist detection devices shall be placed in the expected path of the bicyclists.
- Bicycle detection devices shall be located in the most conspicuous location and supplemented by appropriate signing and pavement markings to inform bicyclists of where to wait.

- Advanced bicycle detection should be installed on the approach to the intersection to extend the phase or to prompt the phase and allow for continuous bicycle through movements.
- The design of loop detectors shall consider the amount of metal in typical bicycles. Certain loop configurations are better at detecting bicyclists than others, and settings for loop detectors shall be adjusted to detect bicycles properly.

(7) Transverse rumble strips

Transverse rumble strips in advance of rural stop-controlled intersections have shown to improve driver awareness and overall safety performance. Therefore, this type of rumble strips may be used in advance of midblock and unsignalized intersections where driver yielding behavior has not been successful with other advance warning treatments identified in this section. Transverse rumble strips shall be installed in accordance with [Standard Plans, Index 546-001](#), [Standard Specifications, Section 546](#), and [FDM 210](#). Consider the following factors when installing transverse rumble strips near midblock or unsignalized intersections:

- (a) The noise impact of installing transverse rumble strips near residential areas should be evaluated before installation.
- (b) Coordination with the District Maintenance Office is required prior to approving the use of the transverse rumble strips.
- (c) There are two basic layouts for transverse rumble strips, extending across the entire traffic lane or placement only in the wheel tracks. The wheel track layout is preferred because it allows drivers that do not need any additional warning to avoid the rumbles without driving into the opposing lane.
- (d) Use the transverse rumble strips in combination with Pedestrian Crossing (*W11-2*) signs.

## 5.2.8 TREATMENT OPTIONS SELECTION MATRIX

Pedestrians treatments at midblock crosswalks and unsignalized intersections shall be selected based on pedestrian volume, roadway context classification, number of lanes, posted speed limit, and other related factors as identified in *TEM 5.2.4*, *TEM 5.2.5*, and *TEM 5.2.7*. As a reference *Figure 5.2-13* has been designed to aid in the treatment option selections process. This matrix highlights the procedures, selection criteria and treatment requirements identified in *TEM 5.2*.

Figure 5.2-13. Midblock Crosswalk and Unsignalized Intersection Selection Guidance Matrix

TEM 5.2 Midblock Crosswalks and Unsignalized Intersection Selection Guidance Matrix			Midblock and Intersections							Midblock		TEM SECTION	
			Pavement Markings				Beacons			Beacons and Signals			
			Special Emphasis Crosswalk				Standard Crosswalk	RRFB		Flashing Beacon	PHB		Traffic Signal
			20 PPH for 1 Hr or 18 PPH for 2 Hr or 15 PPH for 3 Hr or SHARE USE PATH 50% PPH reduction or school zones					2-4 lanes	3-5 lanes With TWTL				
			or C2T, C4, C5 & C6 0-35 MPH	35-45 MPH	45+ MPH	Stop controlled sidestreets and driveways					0-35 MPH		Florida warrants must be met
Pavement Markings	Special emphasis crosswalk	Midblock	M	M	M	N	M	M	M	M	M		
		Intersection	M	M	M	N	M	M	M	N	N		
	Standard crosswalk		N	N	N	M	N	N	N	N	N		
	Other pavement markings		O	O	O	O	O	O	O	O	O		
Signs	R1-5b/R1-5c	Enhance option: highlighted or beacon	O	O	O	O	M	M	O	N	N		
	W11-2/W16-9P		O	O	O	O	M	M	O	O	O		
	W16-7P/FTP-68C-21		O	O	O	O	M	M	O	O	O		
	R1-9a		O	O	O	O	O	O	M	O	O		
	R10-23a		O	O	O	O	O	O	O	M	O		
	Stop for pedestrians in crosswalk			O	O	O	O	O	O	O	O	O	
	In-street sign (R1-6a)	1-4 lanes	R	N	N	O	R	N	O	N	N		
Beacons	Audible message		N/A	N/A	N/A	N/A	M	M	N	N	N		
	In-roadway warning light		N/A	N/A	N/A	N/A	O	O	O	O	N		
Other Treatments	Two-stage pedestrian crossing	Pedestrian refuge islands	O	O	R	O	R	M	O	R	R		
		Raised median	O	O	R	O	O	R	O	R	R		
	Passive pedestrian and bike detection	SHARED USE PATH	N/A	N/A	N/A	N/A	R	R	R	R	R		
		All others locations	N/A	N/A	N/A	N/A	O	O	O	O	O		
	Curb extensions		O	O	R	O	O	O	O	O	O		
	Transverse rumble strips		O	O	O	O	O	O	O	O	O		
	Raised crosswalks		O	N	N	O	O	O	O	O	O		
	Speed reduction treatments		O	O	R	O	O	O	O	O	O		
Overhead lighting		M	M	M	O	M	M	M	M	M			
TEM SECTION			5.2.5.1				5.2.5.2						

Legend

- Mandatory if applied
- Recommend
- Available Option
- Cannot be Applied
- Not Available Option\*

\*Identifies where the treatment cannot be applied because the infrastructure is not there. Ex: Audible Message on a Marked Crosswalk

## **APPENDICES**

## HISTORY

<b>Entire Manual</b>	<b>FDOT Traffic Engineering Manual (TEM)</b>
11/17	Changed name of Department's Design Standards to Department's Standard Plans and updated associated references.
11/17	Updated reference to Transportation Statistics Office to reflect name change to Transportation Data and Analytics Office.
11/16	Updated hyperlinks to reflect change in office section name from Operations to Traffic Services.
01/12	Mandatory changes to incorporate adoption of MUTCD 2009.
12/06	Pen and Ink changes (updated references and/or links).
<b>Chapter 1</b>	<b>Traffic Engineering Manual Adoption Procedure</b>
10/11	Added Section 5 (Traffic Engineering Variations) and Section 6 (Traffic Engineering Variation Process)
03/09	Pen and ink changes.
04/05	Changed office name. Removed rule reference for Section 2.16.
08/03	Changed website address.
03/03	Changed rule incorporation reference to 14-15.015. Updated website address.
03/02	Changed website address. Also created links to references and changed office name to Traffic Operations.
10/01	Approved to have TEM available electronically on the internet/infonet only.
<b>Chapter 2</b>	<b>Signs</b>
11/16	Simplified language.
<b>Section 2.1</b>	<b>Use of Slippery When Wet Signs</b>
03/02	Updated references to Millennium MUTCD and included links to all references.

10/99 Section 2.1.2(3), 2nd paragraph. Added, "These signs should be placed in accordance with MUTCD Table II-1 using a 10-mph deceleration factor."

06/91 Former FDOT Topic Number 750-010-018 incorporated into TEM.

## **Section 2.2 Overhead Street Name Signs**

06/09 Clarified sign design requirements for internally illuminated overhead signs versus standard static panel signs.

04/07 Removed references to Advance Street Name Signs (new Section 2.37). Standardized sign sizes for overhead street name signs on State Highway System.

03/02 Updated references to Millennium MUTCD and included links to all references.

05/00 Section 2.2.4(1) and (2) changed to conform with letter height requirements shown in Table 6.3-1 in the Elder Roadway User Program Section of the TEM.

## **Section 2.3 Signs and Markings at Non-Signalized Intersections of Divided Highways and Crossroads**

03/02 All references in this document are now in the 2002 edition of the Design Standards.

07/00 This section updated to include the mandatory implementation plan for Divided Highways and Crossroads issued by the State Highway Engineer.

06/91 Former FDOT Topic Number 750-010-035 incorporated into TEM.

## **Section 2.4 Symbol Signs on the State Highway System**

03/02 Updated references to Millennium MUTCD and included links to all references.

06/91 Former FDOT Topic Number 750-010-026 incorporated into TEM.

## **Section 2.5 Destination Distance Signs at Rural Interstate and Freeway Exit Ramp Terminals**

06/91 Former FDOT Topic Number 750-010-024 incorporated into TEM.

## **Section 2.6 Bridge Signs and Markings**

- 11/18 Added clarification that placement of W12-2 sign should be at the Stopping Sight Distance
- 06/18 Added new subsection 2.6.5 Guide Signs on Overpasses
- 11/12 Mandatory changes to incorporate maximum vehicle height according to Section 316.515, F.S.
- 04/02 Updated references to Millennium MUTCD and included links to all references. We also standardized lettering size for the cross road signs on overpasses.
- 07/93 Cross Road Name Signs on Overpasses, added that signs can be installed if requested by law enforcement or emergency rescue organizations.
- 06/91 Former FDOT Topic Number 750-010-034 incorporated into TEM.

## **Section 2.7 Place Name Signs on the State Highway System**

- 04/05 Rescinded. Now Part IV of Rule 14-51, F.A.C., Florida's Highway Guide Sign Program.
- 05/02 Minor editorial changes to make current.
- 05/00 Editorial comments. Section 2.7.6(2) revised to add that place name signs located off state right-of-way must conform to statute.
- 06/91 Former FDOT Topic Number 750-010-036 incorporated into TEM.

## **Section 2.8 Move Accident Vehicles from Travel Lanes Signs**

- 06/04 Updated sign references to the 2004 Design Standards. Added optional graphic panel to limited access sign.
- 05/02 Updated references to Millennium MUTCD and included links to all references.
- 06/91 Incorporated into TEM.

## **Section 2.9 No Passing Zone Signs**

- 07/12 Mandatory changes to incorporate MUTCD references.
- 05/02 Created a link to the W14-3 sign in the new federal Standard Highway Signs.

06/91 Incorporated into TEM.

### **Section 2.10 Vending Machine Signs**

06/04 Added sign details.

06/91 Incorporated into TEM.

### **Section 2.11 Guidelines for Bicycle Warning Signs**

10/20 Added guidance for the use of a bicycle passing clearance sign.

05/19 Eliminated references to the “Share the Road” sign and updated the section to include references to the “Bicycle May Use Full Lane” sign.

09/02 Updated references to the Millennium MUTCD and the 2002 Standard Highway Signs Manual.

07/00 Editorial comments. Added Section 2.11.4 to include sign design and instructions for Bicycle Sharing Road Sign. Change initiated due to Revision 5 of the MUTCD.

06/91 Incorporated into TEM.

### **Section 2.12 Recycling Collection Center Signs**

09/04 Updated sign references to the 2004 Design Standards.

09/02 Updated sign references to the 2002 Design Standards.

06/91 Incorporated into TEM.

### **Section 2.13 Signing for Safety Belt Use and Child Restraint Laws**

11/04 Updated sign references to the 2004 Design Standards and Sign Library.

01/03 Updated sign references to the 2002 Design Standards. Updated references to Millennium MUTCD.

07/00 Editorial Comments. Added sign details for all signs. Section 2.13.6 changed to add new design for Standard Safety Belt Sign.

03/93 Former FDOT Topic Number 750-010-014 incorporated into TEM.

## **Section 2.14 Signing for Evacuation Routes**

- 10/20 Updated the FTP number in Section 2.14.4(4). Deleted the requirements for continuous hinge and added a link to the Department's Standard Plans to avoid duplication.
- 06/18 Section renamed to Signing for Emergency Management.
- 06/18 Section updated to reflect most current practices.
- 11/16 Section rewritten to simplify language.
- 11/16 Corrected sign numbers.
- 11/16 Removed Department of Community Affairs, which has been dissolved into Florida Division of Emergency Management.
- 11/16 Added the word inch to clarify measurement.
- 11/16 Corrected phone number.
- 08/01 Changes were made to incorporate the process for signing for one-way operations and also radio frequency information signs during an evacuation. Also, the "hurricane" reference was removed from the title and throughout the document as this section is applicable to all types of evacuations.
- 09/99 Changes were made based on new direction of regional evacuation and sheltering plan. The Department's Emergency Coordination Office initiated changes.
- 08/93 Former Topic Number 750-020-006 incorporated into TEM.

## **Section 2.15 Smoke on Highway Signs**

- 11/18 Section updated to reflect modified smoke management agreement
- 03/02 Changes necessary following the Highway Safety Smoke Management Interagency Agreement. Included sign details for Temporary and Prescribed Burn Signs and requirements for the installation and removal of these signs. Also included links to all references.
- 04/96 Incorporated into TEM.

### **Section 2.16 Signing for Supplemental Guide Signs and Motorist Services on Limited and Non-Limited Access Highways**

04/05 Rescinded. Now Rule 14-51, F.A.C., Florida's Highway Guide Sign Program.

09/99 Formatting changes and converted back to English.

### **Section 2.17 Emergency Highway Traffic Plan**

04/09 Rescinded. Now covered under Topic No. 500-000-104, Emergency Management Program.

06/93 Incorporated into TEM.

### **Section 2.18 \*FHP Highway Assistance Program**

11/04 Updated sign references to the 2004 Design Standards and Sign Library.

01/03 Changed sign detail references to their FTP number in the Design Standards.

04/96 Incorporated into TEM.

### **Section 2.20 Call Box/Mile Marker Signs**

04/14 Rescinded. Call boxes removed from State Highway System.

09/04 Updated sign references to the 2004 Design Standards and Sign Library.

03/99 Section 2.20.2(1) and (2) increased measurement for installation. Also added sign design to include tenth of a mile measurement.

07/97 Incorporated into TEM.

### **Section 2.21 Florida Litter Law Signs**

10/21 Updated FTP numbers of FLORIDA LITTER LAW signs to match the latest Department Standard Plans

10/20 Added a reference and linked to the related Florida statue in Section 2.21.2(2).

06/04 Updated sign references to 2004 Design Standards. Minor revisions recommended by Signing Team.

07/97 Incorporated into TEM.

## **Section 2.22 Traffic Control for Toll Collection Facilities**

- 10/21 Updated reference to Turnpike Design Handbook (TDH).
- 04/09 Rescinded. Now included in Turnpike's Plans Preparation and Practices Handbook.
- 07/98 Former FDOT Topic Number 750-010-010 incorporated into TEM.

## **Section 2.23 Florida's Turnpike and Toll Road Numbering and Signing Program**

- 11/01 Changes made were initiated by Management to include the use of the local road name or logo (to be provided by the local expressway authority) on the toll facility along with our Toll Route Marker. Updated references to Millennium MUTCD and the sign detail for the Toll Route Marker.
- 04/01 Section 2.23.4(3), last sentence. Allowed possibility of local road names to be used in a guide sign or directional sign. Change initiated by management.
- 07/98 Incorporated into the TEM.

## **Section 2.24 Placement of Crime Watch Signs on the State Highway System**

- 05/04 Pen and Ink changes.
- 07/98 Former FDOT Instructional Memo Number 750-005 incorporated into TEM.

## **Section 2.25 Distance Signing for Non-Limited Access Highways**

- 09/99 Incorporated into TEM. Implements Action Plan 006 from our Evaluation of International Signing Practices Study (1994).

## **Section 2.26 Advance Guide Signs on Limited Access Highways**

- 09/99 Incorporated into TEM. Implements Action Plan 007 of our Evaluation of International Signing Practices Study (1994).

## **Section 2.27 Commuter Assistance Signs**

- 09/99 Incorporated into TEM. Developed from discussions with Public Transportation Office.

## **Section 2.28 Reference Location Signs (Mile-Markers)**

- 09/14 Criteria established for both limited and non-limited access roadways.

04/00 Incorporated into TEM. Recommended by DTOEs during statewide meeting.

### **Section 2.29 Use of Fluorescent Yellow-Green Sign Sheeting**

11/18 Section rescinded and the language is now included in the FDOT Standard Specifications for Road and Bridge Construction Section 700.

07/00 Incorporated into TEM. Developed to establish guidelines for the use of this innovative sheeting that was approved by the FHWA.

### **Section 2.30 Signing for One-Stop Career Centers**

08/04 Updated sign references to 2004 Design Standards.

07/00 Incorporated into TEM. Developed from sign request in District Four.

### **Section 2.31 Unique Transportation Symbol Signs**

08/02 Incorporated into TEM.

### **Section 2.32 511 Telephone Service Sign**

10/20 Updated the graphic on the Travel Info Call 511 sign.

06/04 Incorporated new FTP references.

06/02 Incorporated into TEM.

### **Section 2.33 Signing for Nature-based Tourism and Heritage Tourism Trails**

09/02 Incorporated into TEM.

### **Section 2.34 Signing for Florida Scenic Highways Program and the National Scenic Byways Program**

10/04 Incorporated into TEM.

### **Section 2.35 Signing for Memorial Roadway Designations**

07/06 Web address for Sign Library changed.

10/04 Incorporated into TEM.

### **Section 2.36 Wayfinding Signs**

04/07 Incorporated into TEM.

### **Section 2.37 Advance Street Name Signs**

- 11/16 Added clarification that conditions are recommended and not mandatory.
- 11/16 Added language addressing lengthy street name legends and limited right-of-way.
- 11/16 Added language for font size.
- 06/09 In order to provide consistency with the MUTCD, incorporated standards for advance street name signs not only for signalized intersections but non-signalized and the use of advance street name sign plaques for advance warning and intersection control signs.
- 04/07 Incorporated into TEM.

### **Section 2.38 Use of Temporary Stop Signs at Non-Functioning Signalized Intersections**

- 06/18 Section renamed to Use of Generators and Portable Stop Signs at Non-Functioning Signalized Intersections
- 06/18 Section updated to reflect most current practices.
- 01/16 Editorial change to apply to any emergency event.
- 05/07 Incorporated into TEM.

### **Section 2.39 Warning, Stop, and Yield Sign Sizes**

- 10/20 Updated the STOP sign size in Table 2.39-3 to 30 inches for the 20 mph POSTED SPEED.
- 10/07 Pen and ink changes made to table for consistency with final research report.
- 08/07 Incorporated into TEM.

### **Section 2.40 Displaying Messages on Dynamic Message Signs Permanently Mounted on the State Highway System**

- 11/17 Section modified.
- 08/15 New approved messages added
- 08/08 Incorporated into TEM.

### **Section 2.41 Guidelines for Use of Retroreflective Strips**

10/15 Incorporated into TEM.

### **Section 2.42 Express Lanes Signing**

10/21 Added guidance on Periods of Operation sign (R3-44).

05/19 Modified 2.42.4 paragraph (1) to allow more flexibility with the signing order.

06/18 Incorporated into TEM.

### **Section 2.43 Ramp Only Signal Panel**

10/19 Incorporated into TEM.

### **Section 2.44 TURNING VEHICLES STOP FOR PEDESTRIANS Sign**

10/21 Incorporated into TEM.

## **Chapter 3 Signals**

### **Section 3.1 Signalized Intersections Flashing Mode Operation and Flashing Beacons**

12/09 Changes made consistent with MUTCD 2003.

10/93 Page III-1 removed provision that accident patterns need to be monitored at flashing yellow/red locations. Page III-2 removed option for flashing signal operations in relation to closing times.

06/91 Former FDOT Topic Number 750-010-023 incorporated into TEM.

### **Section 3.2 Guidelines for Left Turn Treatment**

12/09 Changes made as recommended by DTOEs, figures added.

08/93 Under Left Turn Signal Phasing, changed left turn separation from 10 to 12 feet.

06/91 Incorporated into TEM.

### **Section 3.3 Scheduling Intersection Control and Funding Arrangements**

10/19 Section name changed to "Scheduling Intersection Control Evaluations and Funding Arrangements."

10/19            Hyperlink added for Manual on Intersection Control Evaluation and FDOT Approved Product List Submittal Process.

10/93            Former FDOT Topic Number 750-010-001 incorporated into TEM.

### **Section 3.4    Emergency Traffic Control Signals**

11/18            Updated figure 3.4-1 and eliminated figure 3.4-2 by incorporation to improve legibility.

06/18            Section updated to reflect most current practices.

11/12            Mandatory changes to provide clarity and revise MUTCD reference.

02/10            Added appropriate MUTCD 2003 signs and references.

04/96            Former FDOT Topic Number 750-020-004 incorporated into TEM.

### **Section 3.5    Traffic Signal Mast Arm Support Boundaries**

02/10            Section title change, references to PPM added, direct links to pdf versions of District Boundary Maps included.

10/98            Incorporated into TEM.

### **Section 3.6    Standardization of Yellow Change and Red Clearance Intervals for Signalized Intersections**

10/20            Added guidance for calculating the yellow change interval and minor editorial updates.

10/13            Changes to yellow change and red clearance intervals: (a) Increased perception reaction time to 1.4 seconds; (b) Round up Yellow Change Intervals to the next 0.1 sec; (c) Increased the minimum Yellow Change Interval to 3.4 seconds; (d) Increased the minimum Red Clearance Interval to 2.0 seconds and the maximum Red Clearance Interval to 6.0 seconds.

09/12            New language added to clarify and give guidance for determining the all-red clearance interval.

07/11            Editorial changes made to clarify the method of determining yellow clearance time.

06/10            Changes necessary to have yellow and all-red intervals consist with ITE's Traffic Engineering Handbook.

07/05 These are guidelines so we changed title to reflect it. Changed from "Standardization of Yellow and All-Red Intervals for Signalized Intersections."

06/02 Incorporated into TEM.

### **Section 3.7 Accessible Pedestrian Signals**

11/18 Entire section updated. "Audible" changed to "accessible".

02/03 Incorporated into TEM.

### **Section 3.8 Railroad Traffic Signal Preemption Time Calculation**

10/21 Added language on preempt trap check and vehicle-date interaction check procedures as well as an example of adding a preemption phase to the traffic control system.

10/20 Incorporated into TEM.

### **Section 3.8 Marked Pedestrian Crosswalks at Midblock and Uncontrolled Approach Locations**

10/20 Rescinded. Information contained in Section 5.2 (Treatments for Pedestrian Crosswalks at Midblock and Unsignalized Intersections).

10/19 Updated hyperlinks for Department's Standard Plans.

05/19 Section modified to include provisions for pedestrian crosswalk treatments that are based on context classifications.

11/18 Updated section to reflect MUTCD language consistency and to clarify the 'average day' language in Section 3.8.5(3)(b).

01/16 Modified to address pedestrian crosswalks at both midblock and uncontrolled approach locations. Added definitions to key terms, revised minimum pedestrian activity thresholds, updated photos, clarified guidance on Pedestrian Hybrid Beacons, and modified guidance on the use of Rectangular Rapid Flashing Beacons on multilane roadways.

10/14 Modified to reflect the language for crosswalk illumination to help implement safe crossing of pedestrians at midblock locations.

06/13 Changes necessary to refine the criteria for installing and operating mid-block pedestrian crosswalks.

01/10 Substantive changes necessary to expand crossing treatments available with appropriate criteria and selection guidance included.

06/03 Changes necessary to conform to the MUTCD 2000 standards.

02/03 Incorporated into TEM.

### **Section 3.9 Installing Signal Backplates on Existing Structures**

10/21 Updated language clarifying the use of rigid and flexible retroreflective backplates.

10/20 Incorporated into TEM.

### **Section 3.9 Countdown Pedestrian Signal Applications**

11/17 Section rescinded.

03/07 Changes necessary to incorporate Department's policy on this device.

07/06 Changes necessary to give direction to districts on implementation.

04/03 Incorporated into TEM.

### **Section 3.10 Flashing Yellow Arrow Signal Application**

10/21 Updated language regarding education materials for flashing yellow arrow and portable changeable message signs.

10/20 Updated guidance on yellow left turn trap and referenced bulletin TEOB 20-02.

11/18 Incorporated into TEM.

### **Section 3.11 Signal Timing Applications for Pedestrian Movement**

10/21 Changed title to "Signal Timing Applications for Pedestrian Movement". Added signal timing definitions from NCHRP Report 812. Revised language pertaining to leading pedestrian interval (LPI) implementation and LPI considerations sections.

10/20 Revised criteria for LPI signal applications requiring engineers to consider LPI for all new traffic signal designs. Provided guidance on LPI applications for protected and permissive left-turn movements.

05/19 Incorporated into TEM.

## **Chapter 4 Markings**

### **Section 4.1 Crosswalks in Heavy Pedestrian Concentration Areas**

11/17 Changed reference to Design Standard to Speed Zone Manual.

- 08/04 Incorporated latest MUTCD 2003 changes.
- 06/91 Former FDOT Topic Number 750-020-008 incorporated into TEM.

#### **Section 4.2 Pavement Word, Symbol, and Arrow Markings**

- 10/21 Revised the language for route shield pavement markings installation criteria.
- 10/19 Changed reference to design of elongated shields.
- 11/18 Updated figure 4.2-3 to improve legibility.
- 11/17 Changed reference to Design Standard to Speed Zone Manual.
- 02/15 Added new subsection for Route Shields for Wrong Way Treatment.
- 05/14 Pen and ink changes to update figures.
- 10/13 Changes necessary to bring the proper clarification for pavement markings and route shields into the TEM.
- 06/91 Former FDOT Topic Number 750-010-020 incorporated into TEM.

#### **Section 4.3 Use of Blue Raised Pavement Markers to Identify Fire Hydrants**

- 10/19 Rescinded.
- 07/98 Former FDOT Instructional Memorandum Number 750-004 incorporated into TEM.

#### **Section 4.4 Roundabout Markings**

- 07/07 Incorporated into TEM.

#### **Section 4.5 Express Lanes Markings**

- 10/21 Added FDM references to the section.
- 10/20 Section updated to replace “express lanes marker” with “Tubular marker” and some editorial changes.
- 11/18 Added new definitions.
- 06/18 Incorporated into TEM.

#### **Section 4.6 Use of Internally Illuminated Raised Pavement Markers**

- 11/18 New section.

## **Chapter 5 Specialized Operational Topics**

### **Section 5.1 Golf Cart Crossings and Operation on the State Highway System**

10/21 Revised the side street maximum vehicular volume and AM/PM peak hour volume criteria for golf cart crossings at full signalized intersections. Updated language on the operation of golf carts on sidewalks. Added language pertaining to the education of golf cart operations.

10/11 Incorporated into TEM in new “Specialized Operational Topics” chapter.

### **Section 5.1 Computer Models for Traffic Engineering and ITS Analysis and Design**

11/10 Rescinded.

06/91 Former FDOT Topic Number 750-030-005 incorporated into TEM.

### **Section 5.2 Treatments for Pedestrian Crosswalks at Midblock and Unsignalized Intersections**

10/21 Updated safety considerations criteria for new marked crosswalks. Revised recommended levels of pedestrian demand threshold criteria and added C3C context classification for pedestrian volume demand exemptions. Added language on nature-based trail crossings and revised language for engineering study.

10/20 Incorporated into TEM by restructuring the rescinded TEM Section 3.8 (Marked Pedestrian Crosswalks at Midblock and Uncontrolled Approach Locations). New guidance has been provided to pavement markings, signs, beacons, signals to improve safety.

## **Chapter 6 Safe Mobility for Life Program**

11/16 Removed.

### **Section 6.1 Elder Road User Program**

04/07 Rescinded. Information contained in section provided on Safe Mobility for Life Program (Topic No. 000-750-001) website.

06/98 Incorporated into TEM. Initiated by Elder Road User Program FDOT Topic Number 000-750-001.

### **Section 6.2 Warning, Stop, and Yield Sign Sizes to Accommodate the Elder Roadway User in Florida**

08/07 Rescinded. Information contained in Section 2.39 (Warning, Stop, and Yield Sign Sizes).

06/98 Incorporated into TEM. Based on research developed from Elder Road User Program.

### **Section 6.3 Intersection Guide Signs**

04/07 Rescinded. Information contained in Section 2.37 (Advance Street Name Signs).

06/98 Incorporated into TEM. Based on research developed from Elder Road User Program.

### **Chapter 7 Approved Product List Certification and Approval Process**

11/16 Removed.

### **Section 7.1 Approved Product List Certification and Approval Process**

07/12 Rescinded. Changed into a local procedure and link shown in section.

03/11 Title changed and APL Vendor Qualification Program was added. Changes made to the Product Approval Process, Temporary Permit Process and APL Review Process. Moved remaining APL procedures from MSTCSD specifications to this section.

03/99 Former FDOT Topic Number 750-010-013 incorporated into TEM.

## INDEX

### Statutes, Rules, and Procedures Pertaining to Traffic Engineering

<b>A.1.1</b>	<b>STATUTES</b>
<b>Chapter 20</b>	<b>Organizational Structure</b>
<a href="#"><u>20.23</u></a>	Department of Transportation
<b>Chapter 258</b>	<b>State Parks and Preserves</b>
<a href="#"><u>258.007</u></a>	Powers of division
<b>Chapter 267</b>	<b>Historical Resources</b>
<a href="#"><u>267.062</u></a>	Naming of state buildings and other facilities
<b>Chapter 316</b>	<b>State Uniform Traffic Control</b>
<a href="#"><u>316.002</u></a>	Purpose
<a href="#"><u>316.003</u></a>	Definitions
<a href="#"><u>316.006</u></a>	Jurisdiction
<a href="#"><u>316.007</u></a>	Provisions uniform throughout state
<a href="#"><u>316.0076</u></a>	Regulation and use of cameras.
<a href="#"><u>316.008</u></a>	Powers of local authorities
<a href="#"><u>316.0083</u></a>	Mark Wandall Traffic Safety Program
<a href="#"><u>316.074</u></a>	Obedience to and required traffic control devices
<a href="#"><u>316.0741</u></a>	High-occupancy-vehicle lanes
<a href="#"><u>316.0745</u></a>	Uniform signals and devices
<a href="#"><u>316.07456</u></a>	Transitional implementation
<a href="#"><u>316.0747</u></a>	Sale or purchase of traffic control devices by nongovernmental entities; prohibitions
<a href="#"><u>316.075</u></a>	Traffic control signal devices
<a href="#"><u>316.0755</u></a>	Pedestrian control signals
<a href="#"><u>316.076</u></a>	Flashing signals
<a href="#"><u>316.0765</u></a>	Lane direction control signals
<a href="#"><u>316.077</u></a>	Display of unauthorized signs, signals, or markings
<a href="#"><u>316.0775</u></a>	Interference with official traffic control devices or railroad signs or signals
<a href="#"><u>316.0776</u></a>	Traffic infraction detectors; placement and installation

<a href="#"><u>316.078</u></a>	Detour signs to be respected
<a href="#"><u>316.079</u></a>	Duty to yield to highway construction workers
<a href="#"><u>316.0875</u></a>	No-passing zones
<a href="#"><u>316.088</u></a>	One-way roadways and rotary traffic islands
<a href="#"><u>316.089</u></a>	Driving on roadways laned for traffic
<a href="#"><u>316.090</u></a>	Driving on divided highways
<a href="#"><u>316.091</u></a>	Limited access facilities; interstate highways; use restricted
<a href="#"><u>316.1001</u></a>	Payment of toll on toll facilities required; penalties.
<a href="#"><u>316.121</u></a>	Vehicles approaching or entering intersections
<a href="#"><u>316.122</u></a>	Vehicle turning left
<a href="#"><u>316.123</u></a>	Vehicle entering stop or yield intersection
<a href="#"><u>316.126</u></a>	Operation of vehicles and actions of pedestrians on approach of authorized emergency vehicle
<a href="#"><u>316.130</u></a>	Pedestrians; traffic regulations
<a href="#"><u>316.1305</u></a>	Fishing from state road bridges
<a href="#"><u>316.1355</u></a>	Driving through safety zone prohibited
<a href="#"><u>316.1575</u></a>	Obedience to traffic control devices at railroad-highway grade crossings
<a href="#"><u>316.171</u></a>	Traffic control devices at railroad-highway grade crossings
<a href="#"><u>316.183</u></a>	Unlawful speed
<a href="#"><u>316.187</u></a>	Establishment of state speed zones
<a href="#"><u>316.189</u></a>	Establishment of municipal and county speed zones
<a href="#"><u>316.1895</u></a>	Establishment of school speed zones, enforcement; designation
<a href="#"><u>316.1945</u></a>	Stopping, standing, or parking prohibited in specified places
<a href="#"><u>316.195</u></a>	Additional parking regulations
<a href="#"><u>316.1995</u></a>	Driving upon sidewalk or bicycle path
<a href="#"><u>316.212</u></a>	Operation of golf carts on certain roadways
<a href="#"><u>316.2122</u></a>	Operation of low-speed vehicle or mini-trucks on certain roadways
<a href="#"><u>316.2125</u></a>	Operations of golf carts within a retirement community
<a href="#"><u>316.2126</u></a>	Authorized use of golf carts, low-speed vehicles, and utility vehicles
<a href="#"><u>316.2127</u></a>	Operation of utility vehicles on certain roadways by homeowners' associations
<a href="#"><u>316.614</u></a>	Safety belt usage

<a href="#"><u>316.75</u></a>	School crossing guards
<b>Chapter 334</b>	<b>Transportation Administration</b>
<a href="#"><u>334.03</u></a>	Definitions
<a href="#"><u>334.035</u></a>	Purpose of transportation code
<a href="#"><u>334.044</u></a>	Department; powers and duties
<a href="#"><u>334.046</u></a>	Department mission, goals, and objectives
<b>Chapter 479</b>	<b>Outdoor Advertising</b>
<a href="#"><u>479.16</u></a>	Signs for which permits are not required
<b>Chapter 553</b>	<b>Building Construction Standards</b>
<a href="#"><u>553. 5041</u></a>	Parking spaces for persons who have disabilities
<b>Chapter 1006</b>	<b>Support for Learning</b>
<a href="#"><u>1006.21</u></a>	Duties of district school superintendent and district school board regarding transportation
<a href="#"><u>1006.23</u></a>	Hazardous walking conditions
<a href="#"><u>1006.66</u></a>	Regulation of traffic at universities
<b>Chapter 1013</b>	<b>Educational Facilities</b>
<a href="#"><u>1013.36</u></a>	Site planning and selection
<a href="#"><u>A.1.2</u></a>	<b>Active Traffic Engineering and Operations Procedures and Policy Statements</b>
<b>A.1.3</b>	<b>Rules</b>
<a href="#"><u>14-15.010</u></a>	Adoption of Manual on Uniform Traffic Control Devices (MUTCD)
<a href="#"><u>14-15.012</u></a>	Speed Zoning for Highways, Roads and Streets in Florida
<a href="#"><u>14-51</u></a>	Florida's Highway Guide Sign Program

# TEEM

## Traffic Engineering Manual

JANUARY 2022



## TABLE OF CONTENTS

### Chapter 1           PROCEDURE

1.1    **Adoption Procedure.....1-1-1**

### Chapter 2           SIGNS

2.1    **Use of Slippery When Wet Signs.....2-1-1**  
    2.1.1    Conditions for Use.....2-1-1  
    2.1.2    Location and Placement.....2-1-1  
    2.1.3    Enhancement.....2-1-2  
    2.1.4    Notification.....2-1-2

2.2    **Overhead Street Name Signs.....2-2-1**  
    2.2.1    Purpose.....2-2-1  
    2.2.2    Standards.....2-2-1  
    2.2.3    Installation.....2-2-2  
    2.2.4    Sign Design.....2-2-2

2.3    **Signs and Markings at Divided Highways and Crossroads.....2-3-1**

2.4    **Symbol Signs on the State Highway System.....2-4-1**  
    2.4.1    Definitions.....2-4-1  
    2.4.2    Conditions for Use.....2-4-1

2.5    **Destination-Distance Signs at Rural Interstate and Freeway Exit Ramp  
Terminals.....2-5-1**  
    2.5.1    Background.....2-5-1  
    2.5.2    Purpose.....2-5-1  
    2.5.3    Conditions for Use.....2-5-1

2.6    **Bridge Signs and Markings.....2-6-1**  
    2.6.1    Bridge and Sign Structure Low Clearance Signs.....2-6-1  
    2.6.2    Bridge Pier Marking.....2-6-1  
    2.6.3    Cross Road Name Signs on Overpasses.....2-6-1  
    2.6.4    Narrow Bridge Treatment.....2-6-2  
    2.6.5    Guide Signs on Overpasses.....2-6-2

2.7    **Place Name Signs on the State Highway System.....2-7-1**

2.8    **Move Vehicles from Travel Lane Sign.....2-8-1**  
    2.8.1    Sign Design.....2-8-1  
    2.8.2    Location and Placement.....2-8-1

<b>2.9</b>	<b>No Passing Zone Signs</b> .....	<b>2-9-1</b>
2.9.1	Purpose.....	2-9-1
2.9.2	Background.....	2-9-1
2.9.2	Conditions for Use.....	2-9-1
<b>2.10</b>	<b>Vending Machine Signs</b> .....	<b>2-10-1</b>
2.10.1	Physical Characteristics.....	2-10-1
2.10.2	Location and Placement.....	2-10-1
<b>2.11</b>	<b>Guidelines for Use of Bicycle Signs</b> .....	<b>2-11-1</b>
2.11.1	Purpose.....	2-11-1
2.11.2	General.....	2-11-1
2.11.3	Bicycles May Use Full Lane (R4-11) Sign.....	2-11-1
2.11.4	Bicycle Passing Clearance Sign.....	2-11-2
<b>2.12</b>	<b>Recycling Collection Center Signs</b> .....	<b>2-12-1</b>
2.12.1	Definition.....	2-12-1
2.12.2	Sign Design.....	2-12-1
2.12.3	Sign Installation.....	2-12-1
<b>2.13</b>	<b>Signing for Safety Belt Use and Child Restraint Laws</b> .....	<b>2-13-1</b>
2.13.1	Purpose.....	2-13-1
2.13.2	Background.....	2-13-1
2.13.3	State Highway System Points of Entry.....	2-13-1
2.13.4	Rest Areas and Interstate Welcome Centers.....	2-13-1
2.13.5	Other Locations.....	2-13-2
2.13.6	Standard Safety Belt Sign (FTP-46-06 and FTP-47-06).....	2-13-2
2.13.7	Sign Design.....	2-13-3
2.13.8	Sign Availability.....	2-13-3
<b>2.14</b>	<b>Signing for Emergency Management</b> .....	<b>2-14-1</b>
2.14.1	Purpose.....	2-14-1
2.14.2	Background.....	2-14-1
2.14.3	Procedure.....	2-14-1
2.14.4	Evacuation Route Sign Design.....	2-14-1
2.14.5	Evacuation Route Sign Use.....	2-14-2
2.14.6	Evacuation Route Sign Placement.....	2-14-2
2.14.7	Sign Installation.....	2-14-2
2.14.8	Shelter and Traveler Information Signing.....	2-14-3
2.14.9	Shelter Sign Design and Use.....	2-14-3
2.14.10	Traveler Information Signing Design and Use.....	2-14-4

2.14.11	Continuous Hinge Requirements.....	2-14-5
2.14.12	Radio Frequency Information Signs.....	2-14-5
2.14.12.1	Radio Frequency Information Sign Design.....	2-14-5
2.14.12.2	Radio Frequency Information Sign Placement.....	2-14-5
2.14.12.3	Radio Frequency Information Sign Installation.....	2-14-7
<b>2.15</b>	<b>Smoke on Highway Signs.....</b>	<b>2-15-1</b>
2.15.1	General.....	2-15-1
2.15.2	Temporary Smoke on the Highway Sign.....	2-15-1
2.15.3	Prescribed Burn Sign.....	2-15-1
<b>2.16</b>	<b>Supplemental Guide and Motorist Services Signs on Limited and Non-Limited Access Highways.....</b>	<b>2-16-1</b>
<b>2.17</b>	<b>Emergency Highway Traffic Plan.....</b>	<b>2-17-1</b>
<b>2.18</b>	<b>*FHP Highway Assistance Program.....</b>	<b>2-18-1</b>
2.18.1	Purpose.....	2-18-1
2.18.2	Sign Location.....	2-18-1
2.18.3	Sign Design and Installation.....	2-18-1
2.18.3.1	Interstate and Other Limited Access Routes.....	2-18-1
2.18.3.2	Major Arterial Routes.....	2-18-2
2.18.4	Sign Availability.....	2-18-2
<b>2.20</b>	<b>Call Box/Mile Marker Signs.....</b>	<b>2-20-1</b>
<b>2.21</b>	<b>Florida Litter Law Signs.....</b>	<b>2-21-1</b>
2.21.1	Purpose.....	2-21-1
2.21.2	Sign Design and Placement.....	2-21-1
2.21.3	Sign Installation.....	2-21-2
<b>2.22</b>	<b>Traffic Control for Toll Collection Facilities.....</b>	<b>2-22-1</b>
<b>2.23</b>	<b>Florida's Turnpike and Toll Road Numbering and Signing Program.....</b>	<b>2-23-1</b>
2.23.1	Purpose.....	2-23-1
2.23.2	Background.....	2-23-1
2.23.3	Road Numbering Program.....	2-23-1
2.23.4	Signing Program.....	2-23-2
2.23.5	Recommended Maximum Trailblaze distance.....	2-23-3
2.23.6	Limited Access Sign Designs.....	2-23-3
<b>2.24</b>	<b>Placement of Crime Watch Signs on the State Highway System .....</b>	<b>2-24-1</b>
2.24.1	Purpose.....	2-24-1
2.24.2	Definitions.....	2-24-1
2.24.3	Background.....	2-24-1

2.24.4	Requests for Signing.....	2-24-1
2.24.5	Sign Locations.....	2-24-1
2.24.6	Sign Design and Placement.....	2-24-2
2.24.7	Installation and Maintenance.....	2-24-2
2.24.8	Special Considerations.....	2-24-3
<b>2.25</b>	<b>Distance Signing for Non-Limited Access Highways.....</b>	<b>2-25-1</b>
2.25.1	Purpose.....	2-25-1
2.25.2	Background.....	2-25-1
2.25.3	Procedure.....	2-25-1
<b>2.26</b>	<b>Advance Guide Signs on Limited Access Highways.....</b>	<b>2-26-1</b>
2.26.1	Purpose.....	2-26-1
2.26.2	Background.....	2-26-1
2.26.3	Definitions.....	2-26-1
2.26.4	Procedure.....	2-26-1
<b>2.27</b>	<b>Commuter Assistance Signs.....</b>	<b>2-27-1</b>
2.27.1	Purpose.....	2-27-1
2.27.2	Background.....	2-27-1
2.27.3	Sign Design and Installation.....	2-27-1
<b>2.28</b>	<b>Reference Location Signs (Mile-Markers).....</b>	<b>2-28-1</b>
2.28.1	Purpose.....	2-28-1
2.28.2	Standards.....	2-28-1
2.28.3	Criteria for Limited Access Roadways.....	2-28-1
2.28.4	Criteria for Non-Limited Access Roadways.....	2-28-1
<b>2.29</b>	<b>Use of Fluorescent Yellow-Green Sign Sheeting.....</b>	<b>2-29-1</b>
<b>2.30</b>	<b>Signing for One-Stop Career Centers.....</b>	<b>2-30-1</b>
2.30.1	Purpose.....	2-30-1
2.30.2	Background.....	2-30-1
2.30.3	Definitions.....	2-30-1
2.30.4	Sign Design and Installation.....	2-30-1
<b>2.31</b>	<b>Unique Transportation Symbol Signs.....</b>	<b>2-31-1</b>
2.31.1	Purpose.....	2-31-1
2.31.2	Background.....	2-31-1
2.31.3	Scope.....	2-31-1
2.31.4	Passenger Ship Sign.....	2-31-1
2.31.5	Amtrak Sign.....	2-31-2
2.31.6	Greyhound Signing.....	2-31-2

2.31.7	Installation and Placement.....	2-31-3
<b>2.32</b>	<b>511 Telephone Service Sign.....</b>	<b>2-32-1</b>
2.32.1	Purpose.....	2-32-1
2.32.2	Sign Design and Placement.....	2-32-1
2.32.2.1	Interstate and other Limited Access Routes.....	2-32-2
2.32.2.2	Major Arterial Routes.....	2-32-2
<b>2.33</b>	<b>Signing for Nature-Based Tourism and Heritage Tourism Trails.....</b>	<b>2-33-1</b>
2.33.1	Purpose.....	2-33-1
2.33.2	Background.....	2-33-1
2.33.3	Pilot Program.....	2-33-1
2.33.4	Criteria for Signing Program.....	2-33-1
2.33.5	DOT Participation.....	2-33-2
2.33.6	Sign Approval and Design.....	2-33-2
2.33.7	Sign Maintenance.....	2-33-3
<b>2.34</b>	<b>Signing for the Florida Scenic Highways Program and the National Scenic Byways Program.....</b>	<b>2-34-1</b>
2.34.1	Purpose.....	2-34-1
2.34.2	Background.....	2-34-1
2.34.3	Program Coordination.....	2-34-2
2.34.4	Sign Criteria.....	2-34-2
2.34.5	Florida Scenic Highway Signs.....	2-34-3
2.34.5.1	Coordination.....	2-34-3
2.34.5.2	Sign Detail.....	2-34-3
2.34.5.3	Sign Installation.....	2-34-3
2.34.5.4	Maintenance.....	2-34-4
2.34.6	National Scenic Byway Signs.....	2-34-5
2.34.6.1	Coordination.....	2-34-5
2.34.6.2	Sign Detail.....	2-34-6
2.34.6.3	Installation.....	2-34-6
2.34.6.4	Maintenance.....	2-34-6
<b>2.35</b>	<b>Signing for Memorial Roadway Designations.....</b>	<b>2-35-1</b>
2.35.1	Purpose.....	2-35-1
2.35.2	Background.....	2-35-1
2.35.3	Signing Process.....	2-35-1
2.35.4	Sign Installation and Maintenance.....	2-35-2
2.35.5	Sign Design.....	2-35-2

<b>2.36</b>	<b>Community Wayfinding Guide Signs</b> .....	<b>2-36-1</b>
2.36.1	Purpose.....	2-36-1
2.36.2	Background.....	2-36-1
2.36.3	Standards.....	2-36-1
2.36.4	Review Process.....	2-36-1
<b>2.37</b>	<b>Advance Street Name Signs</b> .....	<b>2-37-1</b>
2.37.1	Purpose.....	2-37-1
2.37.2	Background.....	2-37-1
2.37.3	Definitions.....	2-37-1
2.37.4	Standards.....	2-37-1
2.37.5	Advance Street Name Signs at Signalized Intersections.....	2-37-2
2.37.6	Advance Street Name Signs at Non-Signalized Intersections.....	2-37-5
2.37.7	Advance Street Name Plaques on Intersection Warning and Advance Traffic Control Signs.....	2-37-6
<b>2.38</b>	<b>Use of Generators and Portable Stop Signs at Non-Functioning Signalized Intersections</b> .....	<b>2-38-1</b>
2.38.1	Purpose.....	2-38-1
2.38.2	Conditions for Use.....	2-38-1
2.38.3	Location and Placement.....	2-38-1
2.38.4	Storage and Distribution.....	2-38-2
2.38.5	Removal and Recovery.....	2-38-2
<b>2.39</b>	<b>Warning, Stop, and Yield Sign Sizes</b> .....	<b>2-39-1</b>
2.39.1	Background.....	2-39-1
2.39.2	Recommended Warning Sign Sizes.....	2-39-1
2.39.3	Recommended Stop Sign Sizes.....	2-39-3
2.39.4	Recommended Yield Sign Sizes.....	2-39-4
<b>2.40</b>	<b>Approved Safety Messages for Permanently Mounted Dynamic Message Signs</b> .....	<b>2-40-1</b>
2.40.1	Purpose.....	2-40-1
2.40.2	Definitions.....	2-40-1
2.40.3	Approved Standard Safety Messages for Display on Permanently Mounted DMS.....	2-40-1
<b>2.41</b>	<b>Guidelines for Use of Retroreflective Strips</b> .....	<b>2-41-1</b>
2.41.1	Purpose.....	2-41-1
2.41.2	Definitions.....	2-41-1
2.41.3	Conditions for Use.....	2-41-1

2.41.4	Sign Design.....	2-41-2
<b>2.42</b>	<b>Express Lanes Signing.....</b>	<b>2-42-1</b>
2.42.1	Purpose.....	2-42-1
2.42.2	Background.....	2-42-1
2.42.3	Criteria.....	2-42-1
2.42.3.1	Vehicle Eligibility Sign.....	2-42-1
2.42.3.2	Express Lanes Termination Sign.....	2-42-2
2.42.3.3	Toll Amount Sign (TAS).....	2-42-2
2.42.3.4	Periods of Operation Sign (R3-44).....	2-42-3
2.42.3.5	Advanced Guide Signs.....	2-42-4
2.42.3.6	Point of Entry/Ingress Signs.....	2-42-4
2.42.3.7	Point of Exit/Egress Signs.....	2-42-6
2.42.4	Sign Sequence.....	2-42-8
2.42.5	Special Consideration for Arterial Entrance/Ingress Connections with Express Lanes.....	2-42-8
<b>2.43</b>	<b>Ramp Only Sign Panel.....</b>	<b>2-43-1</b>
2.43.1	Purpose.....	2-43-1
2.43.2	Background.....	2-43-1
2.43.3	Conditions for Use.....	2-43-1
<b>2.44</b>	<b>Turning Vehicles Stop for Pedestrians Sign .....</b>	<b>2-44-1</b>
2.44.1	Purpose.....	2-44-1
2.44.2	General.....	2-44-1
2.44.3	Guidance.....	2-44-1

## **Chapter 3 SIGNALS**

<b>3.1</b>	<b>Signalized Intersection Flashing Mode Operation and Flashing Beacons .....</b>	<b>3-1-1</b>
3.1.1	Definitions.....	3-1-1
3.1.2	Recommendations for Signalized Intersections.....	3-1-1
3.1.2.1	Programmed Flashing Mode Operation.....	3-1-1
3.1.2.2	Non-Programmed Flashing Mode Operation.....	3-1-2
3.1.3	Application Requirements for Signalized Intersection.....	3-1-2
3.1.3.1	Yellow-Red Flashing Mode.....	3-1-2
3.1.3.2	Red-Red Flashing Mode.....	3-1-2
3.1.4	Heads to Be Flashed.....	3-1-3

3.1.5	Flashing Indication Colors.....	3-1-3
3.1.6	Application Requirements for Flashing Beacons.....	3-1-4
3.1.7	Operation of Flashing Beacons.....	3-1-4
<b>3.2</b>	<b>Guidelines for Left Turn Treatment.....</b>	<b>3-2-1</b>
3.2.1	Purpose.....	3-2-1
3.2.2	Left Turn Signal Phasing.....	3-2-1
3.2.3	Left Turn Signal Displays.....	3-2-3
3.2.4	Signal Display for Exclusive Left Turn Lane.....	3-2-3
3.2.5	Left Turn Phases for Separated Left and Thru Lanes.....	3-2-3
3.2.6	Permissive Only Mode in Multi- Left Turn Lane Approaches.....	3-2-6
<b>3.3</b>	<b>Scheduling Intersection Control Evaluations and Funding Arrangement .....</b>	<b>3-3-1</b>
3.3.1	Purpose.....	3-3-1
3.3.2	General.....	3-3-1
3.3.3	Response to Signal Requests and Scheduling Traffic Signal Studies .....	3-3-1
3.3.4	Traffic Signal Studies and Engineering.....	3-3-2
3.3.5	Funding Arrangements for Warranted New Signal Installations.....	3-3-3
3.3.6	Other Considerations.....	3-3-4
<b>3.4</b>	<b>Emergency Traffic Control Signals.....</b>	<b>3-4-1</b>
3.4.1	Purpose.....	3-4-1
3.4.2	Background.....	3-4-1
3.4.3	Procedure.....	3-4-1
3.4.4	Configuration and Operation of Emergency Traffic Control Signals .....	3-4-2
3.4.5	Emergency Signal Sign (R10-13).....	3-4-3
3.4.6	Other Requirements.....	3-4-3
<b>3.5</b>	<b>Traffic Signal Mast Arm Support Boundaries.....</b>	<b>3-5-1</b>
3.5.1	General.....	3-5-1
3.5.2	Implementation.....	3-5-1
3.5.2.1	Mast Arm Structures Boundary Maps.....	3-5-1
<b>3.6</b>	<b>Standardization of Yellow Change and Red Clearance Intervals for Signalized Intersections.....</b>	<b>3-6-1</b>
3.6.1	Purpose.....	3-6-1
3.6.2	Standard.....	3-6-1
3.6.2.1	Yellow Change Interval.....	3-6-2

3.6.2.2	Red Clearance Interval.....	3-6-3
<b>3.7</b>	<b>Accessible Pedestrian Signals.....</b>	<b>3-7-1</b>
3.7.1	Purpose.....	3-7-1
3.7.2	General.....	3-7-1
3.7.3	Procedure.....	3-7-1
3.7.4	Approval/Denial Process.....	3-7-2
<b>3.8</b>	<b>Railroad Traffic Signal Preemption Time Calculation.....</b>	<b>3-8-1</b>
3.8.1	Purpose.....	3-8-1
3.8.2	Background.....	3-8-1
3.8.3	General.....	3-8-1
3.8.4	Definitions.....	3-8-1
3.8.5	Procedure.....	3-8-4
3.8.6	Preempt Trap Check.....	3-8-8
3.8.7	Vehicle-Gate Interaction Check.....	3-8-9
3.8.8	Example.....	3-8-12
<b>3.9</b>	<b>Installing Retroreflective Signal Backplates on Existing Structures.....</b>	<b>3-9-1</b>
3.9.1	Purpose.....	3-9-1
3.9.2	Background.....	3-9-1
3.9.3	Definitions.....	3-9-1
3.9.4	Procedure.....	3-9-2
<b>3.10</b>	<b>Flashing Yellow Arrow Signal Application.....</b>	<b>3-10-1</b>
3.10.1	Purpose.....	3-10-1
3.10.2	Background.....	3-10-1
3.10.3	Operational Requirements.....	3-10-2
3.10.4	Installation Guide.....	3-10-5
3.10.5	Installation Criteria.....	3-10-6
3.10.6	Variable Mode of Operation.....	3-10-8
3.10.7	Public Notification.....	3-10-8
3.10.8	Education.....	3-10-8
3.10.9	Signal Retrofit Checklist.....	3-10-9
<b>3.11</b>	<b>Signal Timing Applications for Pedestrian Movement.....</b>	<b>3-11-1</b>
3.11.1	Purpose.....	3-11-1
3.11.2	Background.....	3-11-1
3.11.3	Definitions.....	3-11-1
3.11.4	LPI Implementation.....	3-11-3
3.11.5	LPI Considerations.....	3-11-4

## **Chapter 4            MARKINGS**

<b>4.1</b>	<b>Crosswalks in Heavy Pedestrian Concentration Areas.....</b>	<b>4-1-1</b>
4.1.1	General.....	4-1-1
4.1.2	Markings.....	4-1-1
4.1.3	Signing.....	4-1-1
<b>4.2</b>	<b>Pavement Word, Symbol, and Arrow Markings.....</b>	<b>4-2-1</b>
4.2.1	General.....	4-2-1
4.2.2	Lane Use Arrow and “Only” Pavement Markings on Intersection Approaches.....	4-2-2
4.2.3	Route Shield Pavement Markings.....	4-2-3
4.2.4	Route Shields for Wrong Way Treatment.....	4-2-5
<b>4.3</b>	<b>Use of Blue Raised Pavement Markers to Identify Fire Hydrants.....</b>	<b>4-3-1</b>
<b>4.4</b>	<b>Roundabout Markings.....</b>	<b>4-4-1</b>
<b>4.5</b>	<b>Express Lane Markings.....</b>	<b>4-5-1</b>
4.5.1	Purpose.....	4-5-1
4.5.2	Definitions.....	4-5-1
4.5.3	The Words ‘Express’ and ‘Only’ Pavement Markings in Express Lanes .....	4-5-1
4.5.4	Chevrons and Markers in Buffer Area.....	4-5-2
4.5.5	Special Pavement Markings within the Tolling Area.....	4-5-3
<b>4.6</b>	<b>Use of Internally Illuminated Raised Pavement Markers.....</b>	<b>4-6-1</b>
4.6.1	Purpose.....	4-6-1
4.6.2	Definitions.....	4-6-1
4.6.3	Application.....	4-6-1
4.6.4	Procedure.....	4-6-1

## **Chapter 5            SPECIALIZED OPERATIONAL TOPICS**

<b>5.1</b>	<b>Golf Cart Crossing and Operation on the State Highway System.....</b>	<b>5-1-1</b>
5.1.1	Purpose.....	5-1-1
5.1.2	General.....	5-1-1
5.1.3	Definitions.....	5-1-1
5.1.4	Procedure.....	5-1-1
5.1.5	Criteria for Approval of Crossing.....	5-1-3
5.1.6	Operation of Golf Carts on Sidewalks.....	5-1-7

**5.2 Treatments for Pedestrian Crosswalks at Midblock and Unsignalized Intersections.....5-2-1**

- 5.2.1 Purpose.....5-2-1
- 5.2.2 General.....5-2-1
- 5.2.3 Definitions.....5-2-2
- 5.2.4 Procedure.....5-2-3
- 5.2.5 Selection Criteria.....5-2-5
  - 5.2.5.1 Criteria for Marked Crosswalk.....5-2-5
  - 5.2.5.2 Criteria for Beacons and Signals.....5-2-7
- 5.2.6 Engineering Study.....5-2-10
- 5.2.7 Treatment Options.....5-2-12
  - 5.2.7.1 Pavement Markings.....5-2-12
  - 5.2.7.2 Signs.....5-2-14
  - 5.2.7.3 Beacons (Signal Warrant Analysis Not Required).....5-2-19
  - 5.2.7.4 Beacons and Signals (Warrant Analysis Required) .....5-2-22
  - 5.2.7.5 Other Treatments.....5-2-25
- 5.2.8 Treatment Options Selection Matrix.....5-2-28

**APPENDICES**

**History.....A-1**

**Index.....B-1**

PROCEDURE



SIGNS



SIGNALS



MARKINGS



SPECIAL  
OPERATIONAL  
TOPICS



## ADOPTION PROCEDURE

### PURPOSE

To provide traffic engineering standards and guidelines to be used on the State Highway System by the Department's [District Traffic Operations Offices](#).

### AUTHORITY

[Sections 20.23\(4\)\(a\)](#) and [334.048\(3\)](#), Florida Statutes (F.S.)

### SCOPE

The *Traffic Engineering Manual (TEM)* affects the State Traffic Engineering and Operations Office and the District Traffic Operations Offices.

### REFERENCES

[Chapter 316, F.S., State Uniform Traffic Control](#)

[Rule 14-15.010, F.A.C., Manual on Uniform Traffic Control Devices \(MUTCD\)](#)

[Topic No. 025-020-002, Standard Operating System](#)

#### 1. DISTRIBUTION

The official recipient of this manual will be the [District Traffic Operations Engineers \(DTOE\)](#) and their staff, and the [State Traffic Engineering and Operations Office](#) managers and staff.

#### 2. AVAILABILITY

The *TEM* is available free of charge at the Department's [State Traffic Engineering and Operations Office website](#).

#### 3. REGISTRATION

Users of the *TEM* interested in receiving automatic notifications of revisions to the manual by e-mail may subscribe from the Department's website. As required by [Section 283.55, F.S.](#), by March 1 of each odd-numbered year, we will survey e-mail addresses from our current registration list and purge any outdated registrations.

#### 4. REVISIONS AND ADDITIONS

- (1) The [\*\*District Traffic Operations Engineers \(DTOE\)\*\*](#) and the [\*\*State Traffic Operations Engineer \(STOE\)\*\*](#) will constitute the Manual Review Committee.
- (2) Items warranting immediate change will be made with the approval of the [\*\*STOE\*\*](#) (after a majority vote of the Manual Review Committee and consultation with any other affected parties). Statewide meetings of [\*\*DTOEs\*\*](#) will be held every six months, and a major agenda item will be any additions/changes either necessary or recommended to the **TEM**.
- (3) All revisions will be coordinated through the Forms and Procedures Office prior to implementation.
- (4) Substantive revisions or policy-related issues, as determined by the Manual Review Committee, will be approved by the Secretary following the process established in the [\*\*Standard Operating System, Topic No. 025-020-002\*\*](#).
- (5) Once revisions and/or additions have been approved by the Secretary, they will be posted on the [\*\*State Traffic Engineering and Operations Office\*\*](#) website.
- (6) An e-mail notification will be made to all registered holders of the **TEM** that the revisions have been posted on the website.

#### 5. TRAFFIC ENGINEERING VARIATIONS

- (1) The Department's traffic engineering criteria and standards contained in this manual are established by recommended practice of the [\*\*Manual on Uniform Traffic Control Devices \(MUTCD\)\*\*](#) or the [\*\*American Association of State Highway and Transportation Officials \(AASHTO\)\*\*](#) guidelines and/or by specific research conducted for the Department. There may be site specific conditions or certain circumstances that may warrant a variation from the criteria or standards referenced herein. A variation shall be a one-time event on a case-by-case basis or it may be that the **TEM** will be revised to incorporate a variation.
- (2) A request for and subsequent approval of any variation from the criteria and/or standards contained in the **TEM** shall be subject to the procedure established below in **Section 6**.

#### 6. TRAFFIC ENGINEERING VARIATION PROCESS

- (1) A formal written request from a local governmental agency, engineering consultant, or other interested party may be submitted to the appropriate [\*\*DTOE\*\*](#) and should include the following:
  - (a) Proposed location (State Road ID, Mile Post).

- (b) Applicable standard or criterion (Chapter & Section Number).
  - (c) Statement of the reasons why the required criteria or standards are not applicable to the site-specific conditions.
  - (d) Statement of the proposed variation.
  - (e) Statement of how the proposal can be as safe by not following the criteria or standard.
  - (f) Description of other impacts (operations, environmental and community needs).
- (2) The District Traffic Operations Staff will review and evaluate the proposed variation request according to the following guidelines:
- (a) Whether the variation is absolutely necessary for completing a project.
  - (b) Whether other alternatives have been considered that would meet current **TEM** criteria or standards.
  - (c) Whether the proposed variation has been used in other areas – local, state or national. Provide examples, including before and after data, if available.
  - (d) Whether the proposed variation will require Federal Highway Administration approval or coordination.
- (3) If the District Staff believes a variation may be warranted, the **DTOE** shall forward the request for variation to the **State Traffic Engineering and Operations Office** for review.
- (4) If the District Staff believes a variation is not warranted, the **DTOE** shall document the reasons and advise the requestor of the findings.
- (5) Upon review by the **State Traffic Engineering and Operations Office** Staff, the **STOE** shall submit a memorandum concerning the decision for requested variation, including any special conditions or requirement to the appropriate **DTOE**. The **STOE** may consult with the **DTOEs** to obtain statewide consensus prior to approving and authorizing the requested variation.
- (6) The **STOE** memorandum will serve as the formal document authorizing or denying the requested variation from the applicable **TEM** criteria or standard and shall be filed electronically on the **State Traffic Engineering and Operations Office** SharePoint site for future reference.

## **7. TRAINING**

None required.

## **8. FORMS**

None required.

PROCEDURE



SIGNS



SIGNALS



MARKINGS



SPECIAL  
OPERATIONAL  
TOPICS



## Section 2.1

### USE OF SLIPPERY WHEN WET SIGNS

#### 2.1.1 CONDITIONS FOR USE

The [District Traffic Operations Engineer \(DTOE\)](#) shall request the District Maintenance Engineer to erect SLIPPERY WHEN WET (**W8-5**) signs at locations where it has been determined there is a slippery pavement condition. A slippery pavement is defined when a standard friction test at 40 mph has determined the skid numbers are less than 25.

When the posted highway speed is above 45 mph, SLIPPERY WHEN WET signs should be installed when the skid numbers are less than 30, and also one of the following conditions is met:

- (1) When the Safety Ratio (Actual Crash Rate divided by the Critical Crash Rate) is greater than or equal to one.
- (2) Any downgrade greater than 3 percent.
- (3) At intersections with traffic signals.

#### 2.1.2 LOCATION AND PLACEMENT

Additional signs may be needed at locations with the following conditions:

- (1) **Horizontal Curves.** SLIPPERY WHEN WET signs are to be placed prior to the CURVE sign with an advisory speed plate. The ball-bank indicator provides a reasonable speed through the curve; however, a lower speed may be desired if there are known extraordinary hazards such as hydroplaning.
- (2) **Hydroplaning.** Generally, hydroplaning only occurs at speeds above 47 mph; however, excessive runoff across travel lanes may produce hydroplaning at lower speeds. Multi-lane facilities, rutted lanes, built-up shoulders, and downgrades are candidate locations. If excessive water buildup cannot be corrected, then SLIPPERY WHEN WET signs may be appropriate even when skid numbers are greater than 30.
- (3) **Ramp and Bridge Decks.** Interchange exit or entrance ramps on sharp curves and on a downgrade may present a hazardous condition if the pavement is also slippery. Special attention should be given to ramps with compound curves. A pavement friction inventory is normally maintained for interchange ramps; however, special tests, at speeds less than 40 mph can be requested. SLIPPERY WHEN WET signs should be used with an advisory exit speed sign, RAMP XX

MPH (**W13-2**).

SLIPPERY WHEN WET signs shall be placed in advance of all moveable and non-moveable steel deck bridges. These signs should be placed in accordance with [Table 2C-4 of the MUTCD](#).

### 2.1.3 ENHANCEMENT

When roadway surface conditions exist that might adversely affect a motorcyclists' ability to maintain control of their motorcycle under wet conditions, a MOTORCYCLE (**W8-15P**) plaque as shown in **Figure 2.1-1** may be mounted below the warning sign. Additional warnings should be placed at appropriate intervals where the condition exists.

**Figure 2.1-1. Motorcycle Plaque**

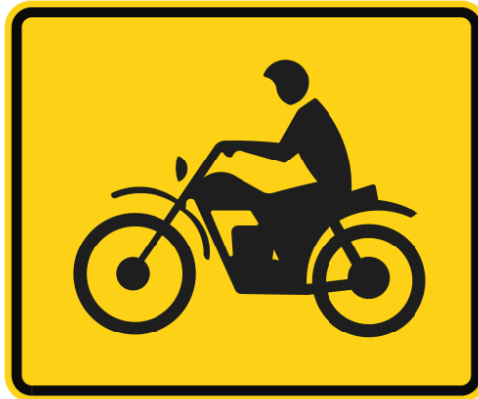

### 2.1.4 NOTIFICATION

- (1) The District Maintenance Engineers will promptly notify in writing the [DTOE](#) when SLIPPERY WHEN WET signs have been erected.
- (2) The [DTOE](#) shall request the District Maintenance Engineer to remove SLIPPERY WHEN WET signs that are no longer warranted under the above provisions.

## Section 2.2

### OVERHEAD STREET NAME SIGNS

#### 2.2.1 PURPOSE

Street name guide signs for most streets that intersect with a road on the state highway system are normally furnished, installed, and maintained by the appropriate local government. However, at signalized intersections on the state highway system, larger overhead street name signs should be used. These signs may be furnished and installed, by the Department.

#### 2.2.2 STANDARDS

- (1) Street name signs shall only be used to identify cross streets. They are not intended to identify destinations such as cities or facilities.
- (2) The word Street, Boulevard, Avenue, etc., may be abbreviated or deleted to conserve sign panel length. However, if confusion would result due to similar street names in the area, for example Seminole Street and Seminole Avenue, this deletion should not be made.
- (3) When a cross street is known by both route number and a local name, use of the local name is preferred on the overhead street name signs since the route number is identified on route markers along the route.
- (4) When a cross street has dual local street name designations, for example N.W. 31 Avenue and Martin Luther King Jr. Boulevard, both names may be used on the overhead street name signs. However, the Department is responsible for the primary designation (i.e., name shown on the Official Florida Transportation Map). If a secondary designation is approved by local resolution, the local government shall be responsible for the installation of this secondary designation.
- (5) When a cross street has a different name on each side of the intersection, both names shall be shown on the overhead street name sign, two signs should be used with one on the left and one on the right side of the intersection. In some instances, the type of signal span design may dictate the need for the use of a single sign with both names. When used, the names should be separated and accompanied by directional arrows, with the left name displayed over the right.
- (6) The display of block numbers is not required when two street names with arrows are provided on a single panel.

## 2.2.3 INSTALLATION

- (1) The location of the overhead street name sign on a signal strain pole and/or mast arm may vary. However, it shall not interfere in any way with the motorist view of the signal heads.
  - (a) For static signs, the preferred installation is shown in the [Standard Plans, Index 659-010](#).
  - (b) For internally illuminated signs, the preferred installation is shown in the [Standard Plans, Index 700-050](#).
- (2) In the case of separate street names on each side of the street, one sign should be placed to the right of the centerline and signal heads and the other to the left side of the centerline and signal heads.

## 2.2.4 SIGN DESIGN

- (1) Overhead street name signs shall be designed in accordance with [Section 2D.43 of the MUTCD](#).
- (2) The sign panel used for overhead street name signs shall be 24 inches in height with length determined by legend.
- (3) At a minimum, 8-inch upper and 6-inch lower case lettering for the street name and 6-inch all uppercase lettering for the block numbering text on the second line shall be used. The preferred font is Series E-Modified; however, Series E may be used to accommodate the amount of legend. An example of this design is shown in [Figure 2.2-1](#).
- (4) When structurally possible, overhead street name signs should be designed in compliance with FHWA recommendations for older drivers ([Section 2D.43 of the MUTCD](#) and [Recommendation I-J-2 of the FHWA Design Handbook for Older Drivers and Pedestrians](#)). When used, the minimum lettering size should be 12-inch upper case with 9-inch lower case.
- (5) Internally illuminated signs should be used whenever possible to provide better night-time visibility, and to benefit older drivers. When used, the devices shall be on the [Department's Approved Products List \(APL\)](#). They shall be designed using a white message on a green background, and if a border is used it shall be white.
- (6) Overhead street name signs using standard panels shall have a white message and border on a green background. If internally illuminated overhead street name signs are not installed, high intensity sheeting should be used for added visibility at night.

- (7) Sign panels should be two-sided in order to provide for a sign display on both the right and left side of each intersection approach.

**Figure 2.2-1. Overhead Street Name Sign**



## Section 2.3

# SIGNS AND MARKINGS AT DIVIDED HIGHWAYS AND CROSSROADS

The Department's standards for this section are shown in the current edition of the [Standard Plans, Indexes 711-001 and 700-109.](#)

## Section 2.4

### SYMBOL SIGNS ON THE STATE HIGHWAY SYSTEM

#### 2.4.1 DEFINITIONS

**Symbol Sign.** Sign used to inform, advise, regulate, or warn of an impending situation where a symbol depicts the approaching situation or information desired.

**Word Message Sign.** Sign used as an alternate to a symbol sign describing by word message an approaching situation or information desired.

**Educational Plaque.** A word message sign used jointly with a new symbol sign to familiarize the motoring public with the meaning of the symbol displayed.

Symbol signs are more easily recognized and better understood by the motoring public. The [MUTCD](#) encourages their use as the primary advisory or warning sign.

With Florida's large tourist population, a broader use of symbol signs is a desirable and important step toward the greater safety and facilitation of traffic. Accordingly, it is appropriate to require the use of symbol signs over word message signs.

#### 2.4.2 CONDITIONS FOR USE

- (1) A symbol sign, if available, shall be used where an advisory, regulatory, or warning sign is warranted to depict an approaching situation or provide information. Word message signs as alternates to symbol signs and educational plaques are generally less effective. However, there may be circumstances where a word message sign is more appropriate. In these cases, the [DTOE](#) should maintain documentation of the exception in district files.
- (2) Any proposed new symbol will require approval as provided in [Section 1A.10 of the MUTCD](#). All requests for a new symbol shall be sent to the [State Traffic Operations Engineer \(STOE\)](#) for review and processing with the Federal Highway Administration.
- (3) When a new symbol sign is utilized, an educational plaque may be used to explain the new symbol by word message as provided in [Section 2A.12 of the MUTCD](#).

## Section 2.5

# DESTINATION-DISTANCE SIGNS AT RURAL INTERSTATE AND FREEWAY EXIT RAMP TERMINALS

### 2.5.1 BACKGROUND

Destination signs (*D1* series) provide guidance information in the form of a destination name and the direction to the destination. Distance Signs (*D2* series) indicate the distance to the destination shown on the sign. Destination and distance signs are especially valuable to motorists unfamiliar with a particular area.

### 2.5.2 PURPOSE

To provide standards and statewide sign design consistency for Destination-Distance signs.

### 2.5.3 CONDITIONS FOR USE

- (1) Combined DESTINATION-DISTANCE (*D1-1a*, *D1-2a*, and *D1-3a*) signs should be used at exit ramp terminals on rural interstates and freeways in lieu of DESTINATION (*D1-1*) signs.
- (2) The combined DESTINATION-DISTANCE sign shall only be used facing exiting traffic from rural interstate and freeway ramps.
- (3) Existing DESTINATION signs at exit ramp terminals should be replaced with the combination DESTINATION-DISTANCE signs during the course of routine sign replacement activities.
- (4) Distances should be determined from the best information available and reflect the distance from the ramp terminal to a control point in the named destination. Control points for all Florida cities that are listed on the official [Florida Distance Chart](#) are maintained by the Transportation Data and Analytics Office.
- (5) In the case of places not on the chart, a control point may be defined by the district, usually as the junction of two main routes within the urban area.
- (6) Distance figures shall be shown just after the destination name. When a sign must accommodate destinations in different directions, a line should divide the destinations as shown in [Figure 2D-7 of the MUTCD](#).
- (7) Signs shall have a white legend on green background. The signs shall be individually detailed in plans and use as a minimum 8-inch numerals and 8/6 upper/lower case lettering.

## Section 2.6

### BRIDGE SIGNS AND MARKINGS

#### 2.6.1 BRIDGE AND SIGN STRUCTURE LOW CLEARANCE SIGNS

- (1) A LOW CLEARANCE (**W12-2**) sign shall be placed at the Stopping Sight Distance of every bridge or structure having a minimum vertical clearance of 14 feet 6 inches or less except as noted below.
- (2) In urban areas, where advance signs could be blocked by traffic or where competition with advertising signs make advance signs ineffective, the LOW CLEARANCE sign or marking should be placed on the bridge beam or equivalent.
- (3) A LOW CLEARANCE sign or marking shall also be placed on the bridge beam or equivalent of every bridge or structure having a minimum vertical clearance of 13 feet 6 inches or less.
- (4) LOW CLEARANCE signing and marking shall conform to additional criteria outlined in [Section 2C.27 of the MUTCD](#).

#### 2.6.2 BRIDGE PIER MARKING

- (1) Bridge piers shall be marked only when they are not protected by a guardrail or a barrier and are less than 30 feet from the near edge of pavement.
- (2) The marking used shall be a Type 3 object marker 12 x 36-inch panel with alternating black and yellow stripes sloped down at an angle of 45 degrees toward the side of the pier which traffic is to pass.
- (3) For additional emphasis, a large surface bridge pier may be treated with sheeting having diagonal stripes at least 12 inches wide and similar in design and application to the Type 3 object marker.

#### 2.6.3 CROSSROAD NAME SIGNS ON OVERPASSES

These signs will no longer be installed, except as requested by law enforcement agencies or emergency rescue organizations. This includes signs mounted on the bridge beam or on posts. When this request is approved, the signs should use 10.67-inch Series E Modified lettering.

## **2.6.4 NARROW BRIDGE TREATMENT**

Signs and markings on narrow bridge approaches shall be as shown in the current edition of the [Standard Plans, Index 700-106](#).

## **2.6.5 GUIDE SIGNS ON OVERPASSES**

See [Section 2.6, Volume 3 of the Structures Manual](#) for limitations on the use of bridge mounted signs.

## Section 2.7

### PLACE NAME SIGNS ON THE STATE HIGHWAY SYSTEM

This section has been rescinded since it is now included in [Rule Chapter 14-51, Part IV of the Florida Administrative Code.](#)

## Section 2.8

### MOVE VEHICLES FROM TRAVEL LANE SIGN

#### 2.8.1 SIGN DESIGN

MOVE VEHICLES FROM TRAVEL LANE (*R16-4*) signs are found in [Section 2B.65 of the MUTCD](#). These signs are used in support of [Section 316.061\(2\), F.S.](#) and replaces the experimental MOVE ACCIDENT VEHICLES FROM TRAVEL LANE sign (formerly *FTP 27-06 and FTP-28-06*.)

Figure 2.8-1. Move Vehicles from Travel Lane Sign

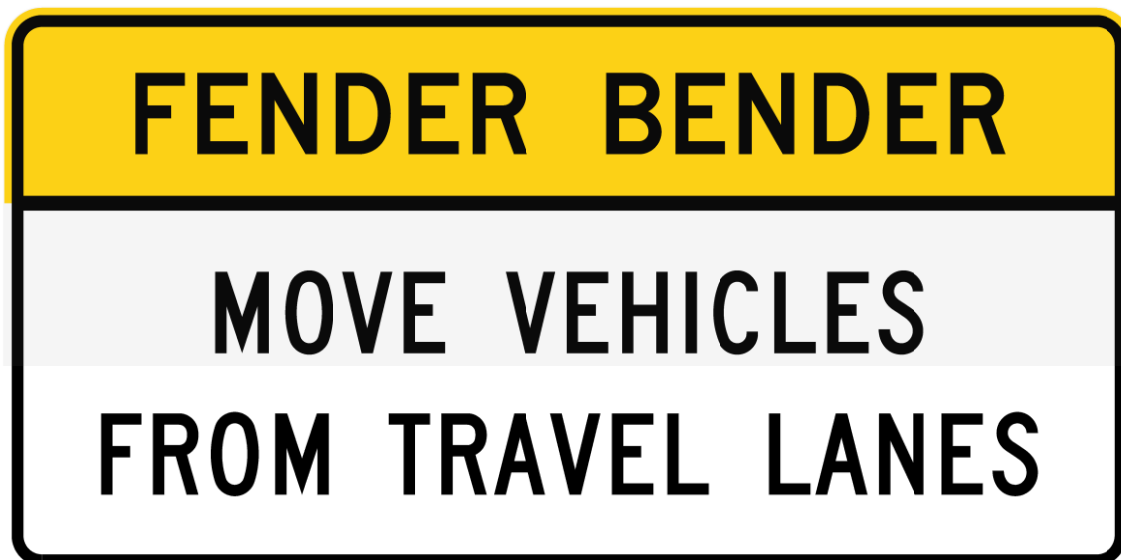

#### 2.8.2 LOCATION AND PLACEMENT

- (1) On non-limited access highways a MOVE VEHICLES FROM TRAVEL LANE (*R16-4*) sign may be used in urban areas when their use will reduce queue lengths and delays, remove interference with traffic signal vehicle detectors, or enhance intersectional capacity. The 42 x 84 inch standard panel uses 6-inch Series C lettering. The 24 x 52 inch standard sign panel has 4-inch Series C letters.
- (2) On limited access highways, a 54 x 120 inch MOVE VEHICLES FROM TRAVEL LANE (*R16-4*) sign using 8-inch Series D lettering may be placed on the right side of urban freeways downstream from entrance ramps when their use will improve driver behavior concerning unnecessary and unlawful constriction of freeway travel lanes due to traffic crashes.

- (3) The MOVE VEHICLES FROM TRAVEL LANE (**R16-4**) sign details are available in the [Standard Highway Signs and Markings Book – Interim Releases for New and Revised Signs](#).
- (4) For permanent installations, specify yellow retroreflective background for the FENDER BENDER enhancement.
- (5) Mounting heights and lateral clearances should adhere to those specified in the [Standard Plans, Index 700-101](#) and support systems shall meet or exceed Department standards of frangibility.

## Section 2.9

### NO PASSING ZONE SIGNS

#### 2.9.1 PURPOSE

To provide guidance on the use of NO PASSING ZONE pennant signs.

#### 2.9.2 BACKGROUND

These signs are used in support of [Section 316.0875, F.S.](#), and [Section 2C.45 of the MUTCD](#) establishes the standards for NO PASSING ZONE pennant signs installed on public roadways.

#### 2.9.3 CONDITIONS FOR USE

- (1) The NO PASSING ZONE (*W14-3*) pennant sign, as shown in **Figure 2.9-1** shall not be used routinely at the beginning of all no passing zones.
- (2) The NO PASSING ZONE pennant sign may be installed as a supplement to pavement markings that establish a no passing zone under the following circumstances:
  - (a) At locations where pavement markings indicating no passing zones are not visible sufficiently in advance to give the driver adequate warning such as on vertical or horizontal curves.
  - (b) Other locations where such signs are determined desirable for safety as a result of an engineering study.
- (3) Proposed use of NO PASSING ZONE pennant signs at locations meeting the above criteria shall be reviewed and approved by the [DTOE](#) prior to installation.

**Figure 2.9-1. No Passing Zone Pennant Sign**



## Section 2.10

### VENDING MACHINE SIGNS

#### 2.10.1 PHYSICAL CHARACTERISTICS

- (1) The VENDING MACHINES sign (**FTP-73-06**) shall be 66 x 30 inches with two lines of legend in 8-inch Series D lettering. The legend and border shall be white on blue background.
- (2) Sign details are available in the [Standard Plans, Index 700-102](#).

#### 2.10.2 LOCATION AND PLACEMENT

- (1) VENDING MACHINES signs will be appended at the bottom and between the supports of REST AREA 1 MILE (**D5-1**) signs. Such placement will not impair the breakaway characteristics of the sign.
- (2) At some rest areas, the VENDING MACHINE message is designed into a sign with flip-up panel which reveals the message SAFETY BREAK / FREE COFFEE (**FTP-74-06, FTP-75-06, and FTP-76-06**).
- (3) Normally, the VENDING MACHINES message will be displayed. However, when the safety break is in effect, the sign is to be folded up to read SAFETY BREAK FREE COFFEE.
- (4) The SAFETY BREAK / FREE COFFEE sign detail is available in the [Standard Plans, Index 700-102](#).

## Section 2.11

### GUIDELINES FOR USE OF BICYCLE SIGNS

#### 2.11.1 PURPOSE

To provide guidance on the use of bicycle signs when a documented need exists. The objective of using bicycle signs is to improve motorist awareness of people biking on State roadways.

#### 2.11.2 GENERAL

- (1) [Chapter 9B](#) and [Section 2C.49 of the MUTCD](#) establish the standards for bicycle signs installed on public roadways. The MUTCD must be reviewed and considered with bicycle sign requests.
- (2) The use of bicycle signs as a warning is shown in [Section 9B.18](#) and [Section 2C.49 of the MUTCD](#). The use of bicycle signs as regulatory is shown in [Section 9B.06 of the MUTCD](#).
- (3) Bicycle signs shall be installed only at locations reviewed and approved by the [DTOE](#).
- (4) The District Bicycle/Pedestrian Coordinator and District Bicycle/Pedestrian Safety Specialist will provide recommendations for all bicycle sign requests and should consider the following conditions when reviewing requests for bicycle signs:
  - (a) context classification
  - (b) land use
  - (c) volumes
  - (d) crash data
  - (e) geometric criteria
- (5) Bicycle signs shall be mounted in accordance with existing Department standards.

#### 2.11.3 BICYCLES MAY USE FULL LANE (R4-11) SIGN

- (1) The BICYCLES MAY USE FULL LANE (**R4-11**) sign is used when it is important to inform road users that bicyclists might occupy the travel lane such as where commuter bicyclists are common users of the facility. The BICYCLES MAY USE FULL LANE (**R4-11**) sign may be installed on roadways when a shared lane

marking ([Standard Plans, Index 711-002](#)) is present or when all of the following conditions exist:

- (a) where travel lanes are less than 14' wide
  - (b) no bicycle lane is present
  - (c) no rideable paved shoulder of 4' width or greater is present
- (2) A shared lane marking is not required for use of the BICYCLES MAY USE FULL LANE (**R4-11**) sign.
- (3) Requests to install BICYCLES MAY USE FULL LANE (**R4-11**) signs on multilane roadways must be submitted by the [DTOE](#) and shall be sent to the [STOE](#) for review and approval.

#### 2.11.4 BICYCLE PASSING CLEARANCE SIGN

- (1) [Florida Statute 316.083](#) requires that vehicles must pass bicycles at a safe distance of not less than three feet. The BICYCLE PASSING CLEARANCE sign (**Figure 2.11-1**) is intended to remind motorists of the three feet minimum clearance State law that a motorist must provide when passing a bicycle.
- (2) The BICYCLE PASSING CLEARANCE sign shall not be installed where a bicycle lane is present.
- (3) The BICYCLE PASSING CLEARANCE sign may be installed on roadways with the following characteristics:
- (a) where there is a designated bicycle route
  - (b) where the BICYCLES MAY USE FULL LANE (**R4-11**) signs are installed
- (4) The BICYCLE PASSING CLEARANCE sign should be installed where there is a documented history of crashes or near misses. Documented history may be obtained from citizen complaints, field observations or crash records.
- (5) Placement of the BICYCLE PASSING CLEARANCE sign should not interfere with the visibility of any existing regulatory or warning signs.
- (6) Sign details are available in the [Department's Sign Library](#).

Figure 2.11-1 Bicycle Passing Clearance Sign



## Section 2.12

### RECYCLING COLLECTION CENTER SIGNS

#### 2.12.1 DEFINITION

**Recycling Collection Center.** A facility open full time to the general public for the purpose of collecting items to be recycled, e.g., oil, aluminum, batteries, etc. The facility may operate as part of a recycling plant or may be a collection center for the distribution of these items to a recycling center elsewhere.

#### 2.12.2 SIGN DESIGN

- (1) The RECYCLING COLLECTION CENTER (FTP-48-06) sign shall be 42 x 60 inches. Lettering shall be 4-inch, Series C. The legend and border shall be white on green.
- (2) The RECYCLING COLLECTION CENTER W/OPTIONAL MUNICIPALITY NAME (FTP-49-06) sign shall be 42 x 66 inches. Lettering shall be 4-inch, Series C. The legend and border shall be white on green.
- (3) A Directional Arrow (M-Series) may be attached below the sign panel if desired.
- (4) Sign details for both the FTP-48-06 and the FTP-49-06 are available in the [Standard Plans, Index 700-102](#), and in the [Department's Sign Library](#).

#### 2.12.3 SIGN INSTALLATION

- (1) Sign requests must be submitted by local government to the appropriate [District Traffic Operations Office](#) for review and approval.
- (2) RECYCLING COLLECTION CENTER signs placed on the State Highway System should adhere to the mounting heights and lateral clearances specified in the [Standard Plans, Index 700-101](#). Support systems shall meet or exceed the standards shown in [Standard Specifications, Section 700](#).
- (3) RECYCLING COLLECTION CENTER signs shall not be permitted in a location where the view of existing traffic control devices may be obscured or where they might otherwise compete for the motorist's attention, for example, next to a stop sign.

## Section 2.13

# SIGNING FOR SAFETY BELT USE AND CHILD RESTRAINT LAWS

### 2.13.1 PURPOSE

To help reduce the number of highway deaths and injuries; to encourage compliance of motorists with the state's safety belt use and child restraint laws; and to establish uniform criteria for district implementation of signing for safety belt use and child restraint laws.

### 2.13.2 BACKGROUND

The Florida Safety Belt Law ([Section 316.614, F.S.](#)), mandates state agencies conduct a continuing safety and public awareness campaign and adopt programs designed to encourage compliance with usage requirements of the safety belt law. It is the intent of this procedure to support the actions of this statute and provide appropriate signing.

### 2.13.3 STATE HIGHWAY SYSTEM POINTS OF ENTRY

- (1) Districts Two and Three shall install and maintain signing at all State Highway System points of entry, informing motorists of the statutory requirement for safety belt use in the State of Florida.
- (2) On limited access highways, a FLORIDA SAFETY BELT AND CHILD RESTRAINT LAW sign (**FTP-44-06**) shall be installed downstream of existing "Welcome to Florida" and speed limit signs.
- (3) On non-limited access highways, a FLORIDA SAFETY BELT AND CHILD RESTRAINT LAW sign (**FTP-45-06**) shall be installed downstream of existing "Welcome to Florida" and speed limit signs.

### 2.13.4 REST AREAS AND INTERSTATE WELCOME CENTERS

- (1) A Rest Area Safety Belt Law sign (**Figure 2.13-1**) shall be installed and maintained in all rest areas and Interstate Welcome Centers informing motorists of the specific requirements of Florida's safety belt and child restraint laws. This sign shall be placed in a prominent location for easy viewing by pedestrians using the facilities.

Figure 2.13-1. Florida Safety Belt Law

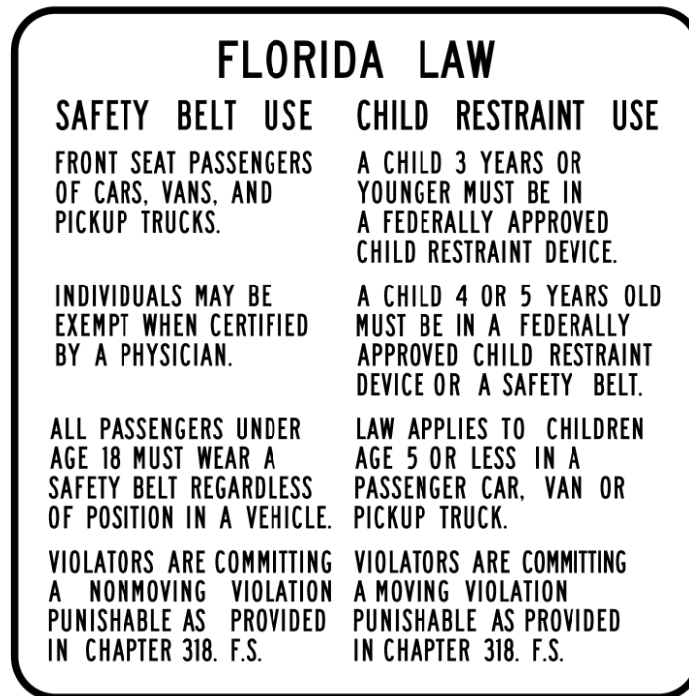

- (2) On the exit from these rest areas and Welcome Centers, the existing “Buckle Up” sign shall be replaced with the FLORIDA SAFETY BELT AND CHILD RESTRAINT LAW sign (**FTP-45-06**), as signs need to be replaced.

### 2.13.5 OTHER LOCATIONS

The FLORIDA SAFETY BELT AND CHILD RESTRAINT LAW sign (**FTP-44-06** and **FTP-45-06**) may be used at other locations on the State Highway System at the discretion of the [D<sub>TOE</sub>](#) but should be limited to locations where:

- (1) There is documented evidence of a high crash location; or
- (2) A high percentage of the traffic is composed of tourists or visitors; and
- (3) The sign will not interfere or detract from existing regulatory, guide, or warning signs or other traffic control devices.

### 2.13.6 STANDARD SAFETY BELT SIGN (FTP-46-06 AND FTP-47-06)

- (1) This sign is to be used for general educational purposes.
- (2) The 36 x 48 inch sign (**FTP-46-06**) should be installed on limited access facilities at county lines, based on space available. The [D<sub>TOEs</sub>](#) may also install this sign

where there is a documented need.

- (3) The 24 x 30 inch sign (**FTP-47-06**) is to be installed on non-limited access highways and urban areas, based on space available and where there is a documented need.

### **2.13.7 SIGN DESIGN**

- (1) Specific sign details for all signs referenced in this section are shown in the [Standard Plans, Index 700-102](#).
- (2) Sign details are available in the [Department's Sign Library](#).

### **2.13.8 SIGN AVAILABILITY**

Maintenance may obtain new or replacement signs by requisition from the Lake City Sign Shop.

## Section 2.14

### SIGNING FOR EMERGENCY MANAGEMENT

#### 2.14.1 PURPOSE

To establish a uniform basis for installing and maintaining emergency management signs on the State Highway System.

#### 2.14.2 BACKGROUND

- (1) The Florida Division of Emergency Management (DEM) plans for both natural and man-made disasters, as well as, prepares and implements a statewide Comprehensive Emergency Management Plan (CEMP). The DEM is the state's liaison with federal and local agencies on emergencies of all kinds and works with local governments to provide technical assistance, as they prepare emergency plans and procedures.
- (2) The DEM requested the Department to install and maintain evacuation route signs on those portions of the State Highway System that comprise official evacuation routes to educate motorists as to the available routes and to ensure that signs are in place well in advance of the actual need to guide motorists away from high-risk areas. Evacuation Route and Zone Maps are located on the DEM website.

#### 2.14.3 PROCEDURE

- (1) The [D<sub>TOE</sub>](#) shall initiate the actions necessary at the district level to implement these guidelines and to ensure that evacuation routes are properly and promptly signed upon request of the County Emergency Management Director. District Maintenance will ensure that the signs are installed and maintained in the field.
- (2) Information on subsequent signing changes and/or additions shall be provided to the DEM for their records and shall be handled by the [D<sub>TOE</sub>](#) upon request of the regional counties and coordinated through the Department's Emergency Coordination Officer.

#### 2.14.4 EVACUATION ROUTE SIGN DESIGN

- (1) The EVACUATION ROUTE sign shall conform to the [Standard Plans, Index 700-102](#).
- (2) A 24-inch diameter Evacuation Route sign (**FTP-78-06**) should be used by local governments to indicate roads or streets under local jurisdiction as official evacuation routes.

- (3) The 36-inch diameter Evacuation Route sign (**FTP-77-06**) shall be used on limited access highways and the 24-inch diameter Evacuation Route sign (**FTP-78-06**) shall be used on non-limited access highways.
- (4) The arrow designs on the **FTP-77-06** or **FTP-78-06** sign shall include a straight, vertical arrow pointing upward, a straight horizontal arrow pointing to the left or right, or a bent arrow pointing to the left or right for advance warning of a turn.
- (5) Sign details are available in the [Department's Sign Library](#).

### **2.14.5 EVACUATION ROUTE SIGN USE**

- (1) The EVACUATION ROUTE sign shall be used exclusively to sign along regional evacuation routes that have been so designated on the approved statewide regional evacuation route plans recorded by the Florida Division of Emergency Management.
- (2) The EVACUATION ROUTE sign shall be used to guide motorists along the regional evacuation routes and away from potential high-risk areas.
- (3) The sign shall comply with applicable provisions of the [Section 2N.03 of the MUTCD](#).

### **2.14.6 EVACUATION ROUTE SIGN PLACEMENT**

- (1) Signs shall be placed in accordance with existing Department standards and be consistent with the [Section 2N.03 of the MUTCD](#).
- (2) The EVACUATION ROUTE sign shall be erected 150 to 300 feet in advance of, and at, any turn in an approved evacuation route and elsewhere for straight-ahead confirmation, if needed. The signs shall be mounted according to height and lateral clearances specified in the [Standard Plans, Index 700-101](#).

### **2.14.7 SIGN INSTALLATION**

- (1) Signs shall be furnished, installed, and maintained by the Department on official evacuation routes that are on the State Highway System.
- (2) Signs shall be installed only at locations reviewed and approved by the [D<sub>TOE</sub>](#) to ensure that such signs do not interfere with existing traffic control devices.

## 2.14.8 SHELTER AND TRAVELER INFORMATION SIGNING

- (1) The [STOE](#) will coordinate, address, and implement operational concerns on evacuation route signing and related operational needs within the Department and with the Florida Division of Emergency Management.
- (2) The [DTOEs](#) will coordinate evacuation shelter signing efforts on a districtwide basis. If signing for shelters or evacuation traveler information is required, the use of the signs must be included in the CEMP area/regional evacuation plan.
- (3) Shelter signing will be installed on highways at key locations. The location determination shall be a joint effort between the [DTOE](#) and the local agencies.
- (4) Signs will be installed under the following conditions:
  - (a) the shelter location is part of the regional plan;
  - (b) the local agency shall purchase the signs;
  - (c) the local agency shall be responsible to "flip-up" or "flip-down" the signs.

## 2.14.9 SHELTER SIGN DESIGN AND USE

- (1) Shelter signs shall have a white background in accordance with [Section 2N.09 of the MUTCD](#).
- (2) The type of shelter signing support used on the State Highway System, portable (temporary), or permanent, will be determined by the [DTOE](#).
- (3) The sign designs for shelters may be permanent or temporary. The permanent design will use a "flip up" design as shown in **Figure 2.14-1**. This means that the bottom panel will be flipped up to reveal the shelter message. The Safety Belt Symbol Sign shall be used as the default message for shelter signs. The CEMP should assign responsibility for turning up the "flip up" signs (**Figure 2.14-1**) during emergency conditions, and back down when conditions return to normal.

Figure 2.14-1. Flip Up Sign

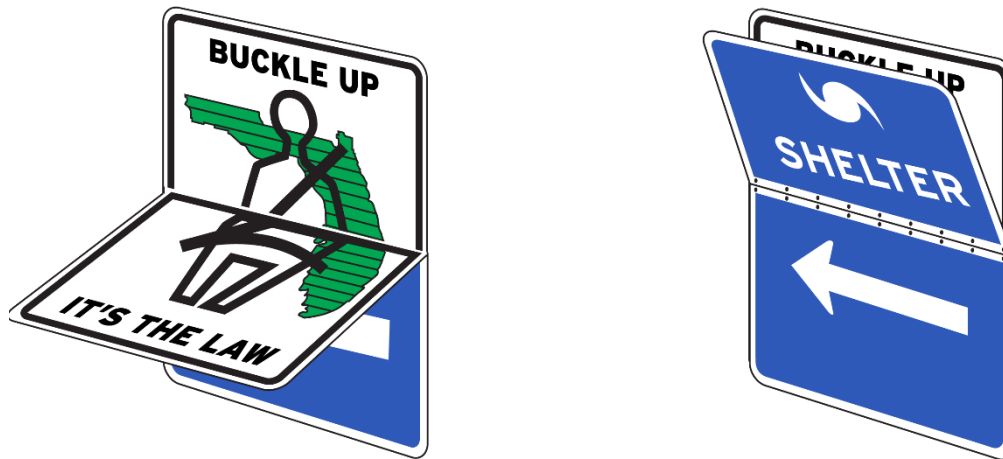

NORMAL POSITION – DOWN

EMERGENCY POSITION – UP

#### 2.14.10 TRAVELER INFORMATION SIGNING DESIGN AND USE

- (1) The Traveler Information sign shall have a blue background with a white legend in accordance with the MUTCD Standard Signs D12 series and [Section 2I.09 of the MUTCD](#). An example is shown in [Figure 2.14-2](#).
- (2) When the local/regional CEMP plan includes the use of traveler information on local shelters and other evacuation information, and a local radio station has a written agreement to be the official traveler information station, the frequency of the station may be signed for on the interstate system. This can be done with Changeable Message Signs, or with permanent flip up signs as shown in [Figure 2.14-1](#). A default message for the “flip up” sign shall be the Safety Belt Symbol sign.

Figure 2.14-2. Traveler Information Sign



## 2.14.11 CONTINUOUS HINGE REQUIREMENTS

The continuous hinge requirements shall be as shown in the current edition of the [Standard Plans, Index 700-010](#).

## 2.14.12 RADIO FREQUENCY INFORMATION SIGNS

The addition of radio frequency information signs along evacuation routes on the State Highway System has been approved by the Department as an important communication link for public safety during evacuation periods. The addition of these signs was made possible when Florida Public Radio Stations volunteered to partner with other state and local agencies in the state's evacuation efforts.

### 2.14.12.1 Radio Frequency Information Sign Design

The Radio Frequency Information sign shall have a blue background with a white legend in accordance with the MUTCD Standard Signs D12 series and [Section 2I.09 of the MUTCD](#).

### 2.14.12.2 Radio Frequency Information Sign Placement

- (1) The Radio Frequency Information Sign (**Figure 2.14-3**) will be placed at the following locations:
  - (a) All limited access highways classified as evacuation routes.
  - (b) Principal non-limited access highways in areas where limited access highways are not the main evacuation routes.
  - (c) Principal non-limited access highways that are critical links leading to limited access highways.
- (2) Limited access highways will consist of an Evacuation Route sign (**FTP-77-06**) sign and a 36 x 24-inch Radio Frequency Information sign (**FTP-70-06**). Exact sign details can be found in the [Standard Plans, Index 700-102](#).
- (3) This sign assembly will be positioned near county lines (where radio coverage is present) and where radio frequency coverage changes. When overlap occurs, the frequency motorists would be driving into is the correct frequency to sign.
- (4) Evacuation routes on the State Highway System non-limited access highways are signed with the Evacuation Route sign (**FTP-78-06**). A 24 x 18-inch Radio Frequency Information sign (**Figure 2.14-3**) will be attached to the existing sign assembly in the above mentioned locations erected close to the county lines or coverage area. Changes are to be modified with the addition of the radio frequency panel. Additional locations to be modified are the beginning and termination points of qualifying links.

- (5) When long segments occur on both limited access and non-limited access highways, confirmation Radio Frequency Information signs should be installed at 10-mile increments.
- (6) **Figure 2.14-4** represents the general statewide radio coverage area for this program.

**Figure 2.14-3. Radio Frequency Information Sign**



Figure 2.14-4. Radio Coverage Area

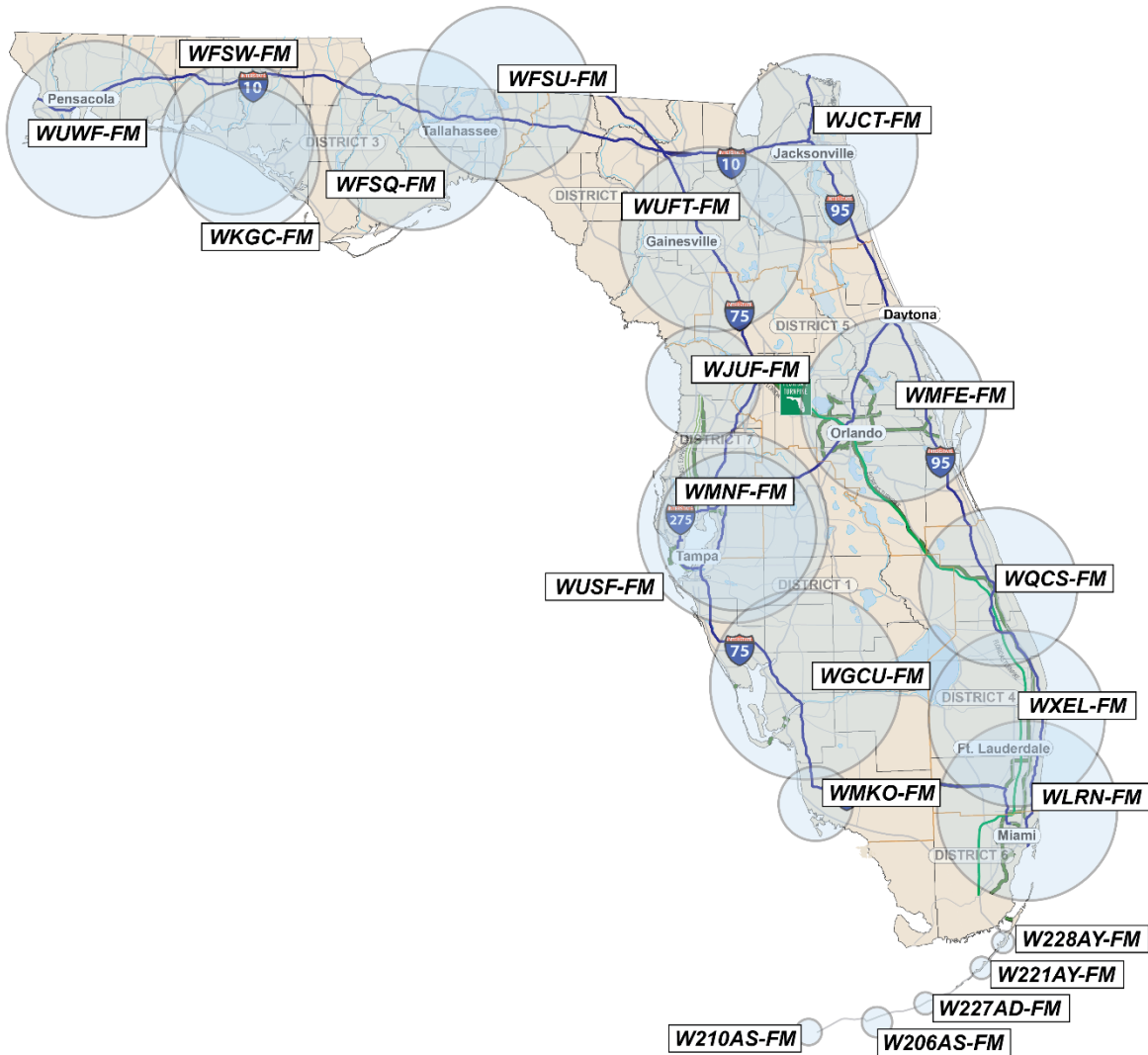

**Note:** WXEL-FM call letters have changed to WPBI-FM  
WFIT-FM has been added to the Florida Public Broadcast membership.

### 2.14.12.3 Radio Frequency Information Sign Installation

- (1) Exact sign locations are to be determined by the [DTOE](#). Work orders should be prepared using the usual procedures for installation by Department Maintenance forces.
- (2) The signs shall be mounted according to height and lateral clearances specified in the [Standard Plans, Index 700-101](#).

- (3) In some cases, the mounting height resulting from attaching an additional panel to an existing sign may be less than the required 7 feet. In rural roadside areas, this situation still meets requirements; however, in urban areas where pedestrians are present, the support must be modified to maintain the required height.

## Section 2.15

### SMOKE ON HIGHWAY SIGNS

#### 2.15.1 GENERAL

- (1) Fires in proximity to highways in Florida can be wildfires or controlled burns under prescribed conditions. In either case, the Florida Department of Agriculture and Consumer Services (FDACS) Florida Forest Service (FFS) is most knowledgeable about smoke conditions.
- (2) A Cooperative Agreement For Response To and Management of Smoke Intrusion On Florida Highways has been developed to provide a cooperative policy and process to warn and advise travelers about roadway visibility conditions resulting from wildfires and prescribed burns. This agreement is between the FFS, FDOT and the Florida Highway Patrol (FHP).
- (3) The use of signs for controlled burns is shown in [Part 5 of the MUTCD](#). The use of signs for incident management is shown in [Chapter 6I of the MUTCD](#).

#### 2.15.2 TEMPORARY SMOKE ON THE HIGHWAY SIGN

- (1) FDOT will supply as needed, temporary incident management signs for use during smoke emergencies.
- (2) FDOT has the authority to place the signs. FFS is authorized, but has no duty, to place the signs to warn motorists of an existing smoke hazard.
- (3) FFS will notify FHP whenever FFS has knowledge that smoke may impact traffic on the state highway system. FDOT and FFS will assist when requested by FHP.
- (4) FFS will coordinate the removal of such signs with FHP or FDOT.
- (5) The signs and support hardware must comply with the Department standards.
- (6) Sign details are available in the [Department's Sign Library](#) under Temporary Smoke on Highway and reads: REDUCE SPEED SMOKE AHEAD.

#### 2.15.3 PRESCRIBED BURN SIGN

- (1) Prescribed burns are pre-planned and approved through the FFS authorization process. Precautionary warning signs on non-limited access roadways may be supplied, erected, and removed by the prescribed fire practitioner planning and executing the burn. The use of temporary precautionary warning signs for prescribed burns is optional.

- (2) Prescribed fire practitioners shall not place precautionary warning signs on limited access public roadways without written approval by FDOT.
- (3) Sign details are available in the [Department's Sign Library](#) under Prescribed Burn and temporary precautionary warning signs will read as follows:  
PRESCRIBED BURN AHEAD.
- (4) Sign materials shall comply with the current edition of the [Standard Specifications, Section 994](#).
- (5) Signs shall be mounted in accordance with the current edition of the [Standard Plans, Index 102-600](#).
- (6) Mounting heights and lateral clearances should adhere to those specified in the current edition of the [Standard Plans, Index 700-101](#):

Case II (rural locations)      Sign edge 12' minimum from driving lane edge

Case V (urban locations)      Sign edge 2' minimum from face of curb

## Section 2.16

# **SUPPLEMENTAL GUIDE AND MOTORIST SERVICES SIGNS ON LIMITED AND NON-LIMITED ACCESS HIGHWAYS**

This section has been rescinded since it is now adopted as Florida's Highway Guide Sign Program in [Rule Chapter 14-51, F.A.C.](#)

## Section 2.17

### EMERGENCY HIGHWAY TRAFFIC PLAN

This section of the TEM has been rescinded and replaced with the [Emergency Management Program \(Topic Number 956-030-001\)](#), which is sponsored by the Emergency Management Office.

## Section 2.18

### \*FHP HIGHWAY ASSISTANCE PROGRAM

#### 2.18.1 PURPOSE

- (1) The \*FHP (347) Highway Assistance Program is a statewide program where motorists wishing to report highway related information to the Florida Highway Patrol, or summon roadside assistance in a Road Ranger service area, can do so by using their cellular phone. Signs will be erected to inform motorists of the cellular phone number.
- (2) The signing program will extend to all Interstate, Toll, U.S. Routes, and other major State Highway System roadways throughout the state.

#### 2.18.2 SIGN LOCATION

The location of these signs should correspond to areas where cellular service is available. The service is available in all counties of the state; however, there are areas in some counties which are not covered.

#### 2.18.3 SIGN DESIGN AND INSTALLATION

- (1) The \*FHP sign (*FTP-43-06*) is 48 x 48 inches, has a white legend on blue background, and the exact sign detail is shown in the [Standard Plans, Index 700-102](#).
- (2) Sign details are available in the [Department's Sign Library](#).
- (3) The \*FHP sign has been revised to provide motorists the number interpretation of FHP (347), in order to quicken the calling process. This new sign design will be used on all new projects and as signs need to be replaced.
- (4) Mounting heights and lateral clearances should adhere to those specified in the [Standard Plans, Index 700-101](#) and support systems shall meet or exceed Department standards of frangibility.
- (5) Specific sign placement details should be developed by the [District Traffic Operations Offices](#) using the following guidelines.

##### 2.18.3.1 Interstate and Other Limited Access Routes

- (1) At state and county lines
- (2) At approximately 30 mile intervals

- (3) Following major freeway to freeway interchanges

### **2.18.3.2 Major Arterial Routes**

- (1) At state and county lines
- (2) At approximately 30 mile intervals
- (3) Downstream from intersections formed by junctions of U.S./Major State Highway System roadways

### **2.18.4 SIGN AVAILABILITY**

Maintenance may obtain new or replacement signs by requisition from the Lake City Sign Shop.

## Section 2.20

### CALL BOX/MILE MARKER SIGNS

This section has been rescinded in accordance with the *Department's DME Memo 13-05, Call Box Removal Plan*. Information on the use of reference markers can be found in *TEM 2.28*.

## Section 2.21

### FLORIDA LITTER LAW SIGNS

#### 2.21.1 PURPOSE

In 1988, the Legislature enacted the ***Solid Waste Act*** which provided for a comprehensive solution to Florida's solid waste problems by involving state and local governmental entities and the private sector. ***Section 55 of the Solid Waste Act*** provided that there must be a coordinated effort to a cleaner environment through sustained programs of litter prevention. ***Subsection 5*** provided that the Department of Transportation must place signs discouraging litter at all off-ramps on the interstate highway system.

#### 2.21.2 SIGN DESIGN AND PLACEMENT

- (1) The FLORIDA LITTER LAW sign is to be installed in compliance with [Section 403.413\(4\), F.S.](#)
- (2) The Department shall install the FLORIDA LITTER LAW sign (***FTP-41-21***) on interstate off-ramps as required by statute ([Section 403.4131\(2\), F.S.](#)). They should be installed a minimum of 100 feet in advance of the first motorist services sign, or a minimum of 100 feet in advance of directional signs on the off-ramps without motorist service signs.

Figure 2.21-1. FLORIDA LITTER LAW Sign (FTP-41-21)



- (3) The off-ramp sign shall be 30 x 36 inches with a white background and black legend (***FTP-41-21***). The specific sign detail is shown in the [Standard Plans, Index 700-102](#).

- (4) The Department may also install the FLORIDA LITTER LAW sign (***FTP-40-21***) on the interstate where there is excessive littering. This sign shall be 42 x 48 inches with a white background and black legend. The specific sign detail is shown in [\*\*Standard Plans, Index 700-102\*\*](#).
- (5) Sign details are available in the [\*\*Department's Sign Library\*\*](#).

### **2.21.3 SIGN INSTALLATION**

- (1) Installation of these signs should be completed through the normal methods of locating the sign positions and notifying District Maintenance. Maintenance will order the signs from the Sign Shop and install them.
- (2) The FLORIDA LITTER LAW sign (***FTP-41-21***) may also be installed on the State Highway System either by the [\*\*DTOE\*\*](#) or by local government through the Department's permit process.
- (3) Mounting heights and lateral clearances should adhere to those specified in the [\*\*Standard Plans, Index 700-101\*\*](#) and support systems shall meet or exceed Department standards of frangibility.

## Section 2.22

# TRAFFIC CONTROL FOR TOLL COLLECTION FACILITIES

The Department's standards for this section are now referenced in the [Turnpike Design Handbook \(TDH\)](#).

## Section 2.23

# FLORIDA'S TURNPIKE AND TOLL ROAD NUMBERING AND SIGNING PROGRAM

### 2.23.1 PURPOSE

To establish standards for systematic numbering and signing of Florida's emerging toll road system.

### 2.23.2 BACKGROUND

- (1) Florida's toll road system was originally made up of a complex network of locally developed expressways and the Florida Turnpike. The toll roads were developed largely through the efforts of local expressway authorities to serve regional transportation needs, seldom extending into adjacent counties. As locally funded and developed projects, the expressway's authorities developed a sense of community ownership for the toll road and gave it a locally pleasing name. These names have traditionally been used when referring to the roadway even though state road numbers were assigned to each facility.
- (2) [Section 338.01, F.S.](#), which has created an intrastate highway system, changed the local flavor of the toll roads. Now considered a major component of the intrastate system, the toll roads perform a necessary function in transporting the motorist through urban areas in the shortest possible time. Consequently, the Turnpike District of the Department is responsible for the administration and expansion of many of the toll roads. Some of these are already open, others are in the planning stages.
- (3) As toll roads have expanded and developed over time into a statewide toll network, a systems approach has been adopted to include connections to other systems. This includes accessibility to local streets, county roads, state system routes, and connections between other limited access systems. An integral part of this interconnected system is the road numbering and signing program.

### 2.23.3 ROAD NUMBERING PROGRAM

- (1) Because of the expanding size of the toll system, the convention of identifying toll roads only by local names is not acceptable. The high number of toll roads and their interconnected nature causes navigation problems for tourists and other non-familiar motorists. A worst case can develop where one expressway joins another and the route name suddenly changes without changing roadways. The solution is to use a route numbering system, similar to that used on interstate routes, U.S. routes, and other state highways.

- (2) Local names or logos will be retained for identification and a local sense of ownership only. Local names or logos will continue to be used by resident motorists, but those not familiar with the local system will rely on the numbering system to navigate the statewide system of toll facilities.
- (3) The numbering system will be consistent with the statewide numbering systems for all state and county roads. In most cases the existing state road numbers will be used to refer to the toll roads. For new tollways, a number will be assigned by the Transportation Data and Analytics Office, consistent with the official numbering program. In cases where future facilities will result in the completion of a loop or beltway, connecting a series of shorter toll road segments, a single road number will be retained, often requiring a change of road numbers on older links.
- (4) To express membership in the statewide toll system, and provide a consistent method of identification throughout the State, a sign has been developed (**Figure 2.23-1**) which depicts the toll road number on a unique sign shape. This sign is similar to an interstate shield and is used as a route marker and as part of the trailblaze assembly.

**Figure 2.23-1. Toll Route Marker**

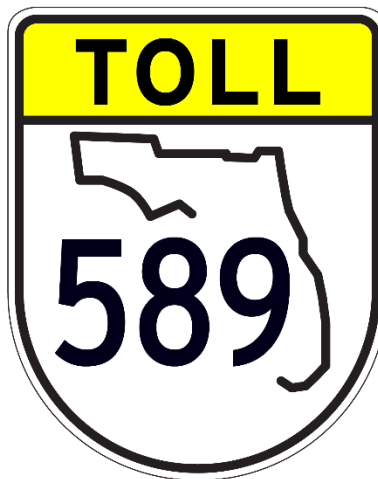

#### **2.23.4 SIGNING PROGRAM**

- (1) The toll route marker (**Figure 2.23-1**) is available in three sizes, depending on application. To identify the facility along the mainline a 48 x 60-inch toll route marker may be used. This sign may be used when leaving the toll plaza to confirm the route and also erected periodically along the mainline.
- (2) To maintain the local identity of the toll road, and provide for local area motorists, the toll road name or logo may be erected on a confirmation guide sign downstream from the mainline toll plazas. If used, the logo panel shall be

furnished by the local expressway authority. These local name or logo signs are for identification purposes only. No attempt shall be made to use only the local toll road name or logo in guide signing, direction signing or trailblazing to the facility. A combination of route number signs and expressway names or logos may be necessary to accommodate local concerns, but the principal identification is the toll route marker.

- (3) To identify a toll facility at a freeway to freeway interchange, both the advance guide sign and exit direction guide sign shall use the 36 x 48-inch toll route shield. This size is available as an overlay, and should also be used in other freeway type guide signs and overhead direction sign applications. The local toll road name or 36-inch logo panel may be used in a guide sign or direction sign application. If used, this logo panel shall be furnished by the local expressway authority.
- (4) To identify a toll facility from a conventional road, (state, county, or local systems), or to provide trailblazing to a toll facility a 24 x 30-inch toll route marker shield shall be used in conjunction with the appropriate cardinal direction information, arrows, junctions, etc. The local toll road name or a 24-inch logo panel may be used in conjunction with the toll route marker. If used, this logo panel shall be furnished by the local expressway authority. Confirmation assemblies should be used in trailblazing beyond intersections of numbered routes. Sign details are available in the [Department's Sign Library](#).
- (5) Although trailblazing to toll facilities is an effective method of advertising for the facility, the intent of signing is to guide the motorist. The [MUTCD](#) is very specific on this issue. General limits on the maximum distance from a toll facility to parallel routes are recommended for rural and urban density development as follows.

### 2.23.5 RECOMMENDED MAXIMUM TRAILBLAZE DISTANCE

Rural density	5 miles
Urban density	2 miles

Due to the cost of signing and the possibility of overloading the motorist with information, the engineer must use care in locating these signs. Acceptable locations are along major parallel routes, and at the junction of roadways which have exits on the toll road.

### 2.23.6 LIMITED ACCESS SIGN DESIGNS

- (1) For general issues relating to guide signs and the use of regulatory and warning signs, the toll system shall be interpreted as functioning as a fully access controlled roadway with corresponding criteria such as clear zone requirements, letter height, sign placement, etc. (See [Section 2E.02 of the MUTCD](#)). The

engineer must keep in mind that this level of signing is purposefully kept simple and dignified, using large lettering, and concise messages that can be read, comprehended, and acted upon while traveling at a high rate of speed.

- (2) The procedures used for guide sign sequences shall be as for other limited access facilities. The use of supplemental guide signs for traffic generators shall follow [Rule 14-51.020, F.A.C.](#)

## Section 2.24

# PLACEMENT OF CRIME WATCH SIGNS ON THE STATE HIGHWAY SYSTEM

### 2.24.1 PURPOSE

To aid districts in evaluating and responding to requests for erecting Crime Watch Signs within the State Highway System rights-of-way.

### 2.24.2 DEFINITIONS

**Crime Watch Sign.** A sign used to identify a neighborhood, community, or other geographical area within which there exists a Crime Watch Program.

### 2.24.3 BACKGROUND

- (1) Crime prevention is an issue of critical concern to both government and its citizens. With the assistance of law enforcement agencies, local citizens have organized Crime Watch Programs to enhance the safety and security of persons and property within their communities. According to law enforcement officials, the erection of Crime Watch Signs indicative of the adoption of a Crime Watch Program can be a deterrent to crime. Generally, local governments erect these signs along residential streets and in business districts.
- (2) Crime Watch Signs shall not be considered official traffic control devices and accordingly are not governed by the [MUTCD](#). However, they do aid in law enforcement and contribute to public safety.

### 2.24.4 REQUESTS FOR SIGNING

- (1) Requests for permitting the erection of Crime Watch Signs within State Highway System rights-of-way should be reviewed by the [DTOE](#).
- (2) Only requests submitted by local government traffic engineering or law enforcement agencies should be considered. Others should be referred to their local governmental agencies.

### 2.24.5 SIGN LOCATIONS

- (1) Crime Watch Signs may be permitted along a state highway only in the vicinity of strip residential or commercial development which is directly accessed from the state highway.
- (2) Crime Watch Signs should not be permitted on state highway right-of-way when

the area of concern is adequately served by side streets connecting to the state highway. In such cases, the signs should be placed on the side street right-of-way and be readily visible to someone entering the side street from the state highway.

- (3) Excessive posting of Crime Watch Signs along a state highway should not be permitted. Prudent judgment must be exercised in reviewing signing strategies with respect to the spacing of successive signs. For example, on highways passing through isolated small rural or suburban communities, single signs at the limits of the communities may be appropriate. In heavily developed areas, additional signs at moderate spacing may be needed.
- (4) Crime Watch Signs shall not be permitted in a location where the view of existing traffic control devices may be obscured or where they might otherwise compete for the motorists' attention (e.g., next to a STOP Sign).

#### **2.24.6 SIGN DESIGN AND PLACEMENT**

- (1) Since Crime Watch Signs are not official traffic control devices, requests for the Department to design or establish standards for these signs should be declined. However, the [DTOE](#) should review sign designs proposed for use on the State Highway System. Designs which resemble an official traffic control device or which may be confusing to or misconstrued by the motorists should be rejected.
- (2) Sign designs should be simple and dignified, devoid of any advertising. Panel design and quality should be adequate to maintain a high level of appearance and legibility under anticipated environmental conditions, both day and night.
- (3) Mounting heights and lateral clearances should adhere to those specified in the [Standard Plans, Index 700-101](#) and support systems shall meet or exceed Department standards of frangibility.
- (4) Crime Watch Signs shall not be affixed to any sign support maintained by the Department.

#### **2.24.7 INSTALLATION AND MAINTENANCE**

- (1) A local governmental agency must agree to assume full responsibility for the installation and maintenance of any Crime Watch Signs permitted by the Department for installation on the State Highway System.
- (2) The installing agency should be advised that the Department reserves the right to remove any Crime Watch Signs not in conformance with these instructions or which are not properly installed or maintained.

## **2.24.8 SPECIAL CONSIDERATIONS**

Unusual requests or designs, or problems associated with Crime Watch Signs on the State Highway System should be discussed with the [\*\*STOE\*\*](#) prior to permitting.

## Section 2.25

### DISTANCE SIGNING FOR NON-LIMITED ACCESS HIGHWAYS

#### 2.25.1 PURPOSE

To establish a consistent distance signage system for all non-limited access state roads in conformance with [Section 2D.41](#) and [Section 2D.42 of the MUTCD](#).

#### 2.25.2 BACKGROUND

- (1) [Section 2D.37 of the MUTCD](#) does address the application of distance signage. However, there is no statewide procedure for distance signage on non-limited access roads. This perpetuates the situation of signing for a destination on a non-limited access state road that may be several hundred miles away. Also, the current distance signage practice does not take into consideration the use of Interstate and Florida's Turnpike System for long distance driving by motorists.
- (2) The Department's current non-limited access distance signs do not provide adequate destination information for motorists who are looking for the variety of tourist attractions which are accessible from non-limited access highways in addition to destinations accessible from the Interstate and Florida's Turnpike System.

#### 2.25.3 PROCEDURE

- (1) Distance signs should have the names of three cities, towns, significant geographical identity, route, or community, and the distance (to the nearest mile) to those places.
- (2) The top name should be the next place on the route having a post office, railroad station, route number (name) of an intersecting highway, or other significant geographical identity.
- (3) The middle name should be used to indicate communities along the route or important route junctions. This name may be varied on successive distance signs to give motorists maximum information concerning communities along the route to the next control city.
- (4) The bottom name must a major destination control city. The control city should remain the same on all successive distance signs throughout the length of the route until that destination qualifies to be the top or middle name on the distance sign. Once the control city moves up, the next control city must be shown as the bottom name. There should always be a control city shown as the bottom name.

- (5) **Figure 2.25-1, Figure 2.25-2, Figure 2.25-3, and Figure 2.25-4** are examples of distance signs for non-limited access highways.
- (6) Placement of distance signs are specified in [Section 2D.42 of the MUTCD](#).
- (7) Control cities have populations of 10,000 or more and include county seats. A matrix that includes the centroid defined for each municipality on the list can be found on the [Intercity Mileage Spreadsheet](#), maintained by the Transportation Data and Analytics Office.
- (8) The implementation of this distance signing program should be through normal construction projects. The [DTOE](#) must develop corridor distance signage plans for inclusion into existing work program projects. Stand-alone distance signage projects are not required or desired.

**Figure 2.25-1**



City "A"	5
Town "B"	10
Control City "A"	20

**Figure 2.25-2**

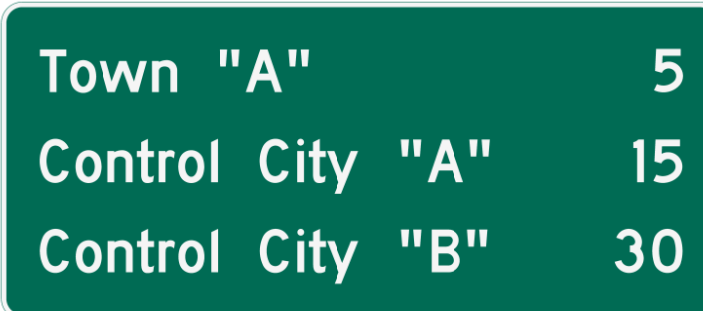

Town "A"	5
Control City "A"	15
Control City "B"	30

Figure 2.25-3



Town "B"	5
Control City "A"	15

Figure 2.25-4

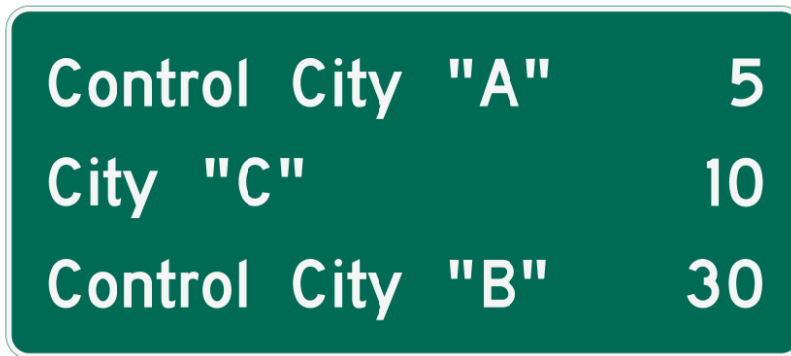

Control City "A"	5
City "C"	10
Control City "B"	30

## Section 2.26

### ADVANCE GUIDE SIGNS ON LIMITED ACCESS HIGHWAYS

#### 2.26.1 PURPOSE

To provide uniform statewide advance guide sign applications that ensure motorists are provided advance notification of interchange exits on limited access highways.

#### 2.26.2 BACKGROUND

The Department's *International Signing Practices Study* recognized the need of the international tourist for advance notification of exit direction information. The most frequently cited problem of international visitors navigating in Florida was the lack of information about exits. Since this need is not limited to the international tourist, but to every unfamiliar motorist and also older drivers from both in and out-of-state this section was developed. The application for interchange guide signs is currently addressed in [Section 2E.30 of the MUTCD](#).

#### 2.26.3 DEFINITIONS

The following definitions apply to this section and are in accordance with [Section 2E.32 of the MUTCD](#):

**Intermediate Interchange.** An interchange with urban and rural routes not in the category of major or minor interchanges.

**Major Interchange.** Subdivided into two categories: (a) interchanges with other expressways or freeways, or (b) interchanges with high-volume multi-lane highways, principal urban arterials, or major rural routes where the volume of interchanging traffic is heavy or includes many road users unfamiliar with the area.

**Minor Interchange.** An interchange where traffic is local and very light, such as interchanges with land service access roads. Where the sum of the exit volumes is estimated to be lower than 100 vehicles per day in the design year.

#### 2.26.4 PROCEDURE

- (1) For urban areas, two advanced guide signs are required for every major and intermediate interchange on the Interstate, Florida's Turnpike System, and other limited access roadways.

- (2) The two advance guide signs should be placed 1/2 mile and 1 mile upstream of the exit. If interchange spacing prohibits the placement of these two advanced guide signs, then the interchange sequential series signs ([Section 2E.40 of the MUTCD](#)) should be used. Left hand exit interchanges should utilize diagrammatic signs.
- (3) For major and intermediate interchanges, the two advance guide signs must be mounted overhead in urban areas. For rural interchanges either cantilever or ground mounted signs are adequate.
- (4) For major interchanges in the rural area and freeway-to-freeway interchanges, three (3) advance guide signs must be provided and located approximately 1/2 mile, 1 mile, and 2 miles upstream from the exit. For rural intermediate interchanges, two advance guide signs are to be installed.
- (5) Implementation of this advance guide sign program should be through construction projects scheduled in the work program. The [DTOE](#) must develop a list of interchanges for inclusion into the work program projects. Stand-alone advance guide sign projects are not required to comply with this standard.

## Section 2.27

### COMMUTER ASSISTANCE SIGNS

#### 2.27.1 PURPOSE

To provide statewide sign design consistency for the Department's Commuter Assistance Program, [Topic Number 725-030-008](#).

#### 2.27.2 BACKGROUND

Coordinated use of existing transportation resources can provide a responsive, low cost alternative for alleviating urban highway congestion and improving air quality, thereby reducing the need for costly highway improvements. The Commuter Assistance Program focuses on the single occupant commuter trip which is the greatest cause of peak hour highway congestion. A coordinated effort to provide alternatives to these commuters, using existing or low-cost resources, can be beneficial to the development of a transportation demand management program and public transit statewide. The State's Commuter Assistance Program encourages a public/private partnership to provide services to employers and individuals for: carpools, vanpools, express bus service, subscription transit service, group taxi services, heavy and light rail, and other systems which are designed to increase vehicle occupancy.

#### 2.27.3 SIGN DESIGN AND INSTALLATION

- (1) [Section 2I.11 of the MUTCD](#) provides guidance for the installation of a carpool information sign.
- (2) Signing requests received from the Department's Public Transit Office or local transit agencies must be approved by the [DTOEs](#).
- (3) Sign placement will be determined by District Traffic Operations based on field review and space availability.
- (4) The Department's Commuter Assistance Program also includes two additional modes of services (vanpooling and transit) and there are different signs for each of these services.
- (5) There are two different sizes for each sign design. The arterial sign shall be 36 x 24 inches. The interstate sign shall be 78 x 48 inches. All signs shall be blue reflective background with white lettering.

- (6) Exact sign details for the TRY CARPOOLING (***FTP-56-06 and FTP-56A-06***) TRY TRANSIT (***FTP-59-06 and FTP-60-06***) and TRY VANPOOLING (***FTP-57-06 and FTP-58-06***) are available in the [\*\*\*Standard Plans, Index 700-102\*\*\*](#).
- (7) Sign details are available in the [\*\*\*Department's Sign Library\*\*\*](#).
- (8) Mounting heights and lateral clearances should adhere to those specified in the [\*\*\*Standard Plans, Index 700-101\*\*\*](#) and support systems shall meet or exceed Department standards of frangibility.

## Section 2.28

### REFERENCE LOCATION SIGNS (MILE-MARKERS)

#### 2.28.1 PURPOSE

To establish consistent criteria and signing methods for reference location signs (mile markers) on both limited and non-limited access roadways.

#### 2.28.2 STANDARDS

- (1) Reference location signs shall be as described in [Section 2H.05](#) and [Section 2H.06 of the MUTCD](#). These signs consist of a vertical panel containing the mile-marker number. The sign shall have 6-inch white letters on a green reflective background and be placed on the right side of the roadway at 1-mile or 1/2-mile increments as detailed in [TEM 2.28.3](#) and [TEM 2.28.4](#).
- (2) The zero distance shall be established at the southern or western state line or at junctions where the route begins. [MUTCD](#) standards shall be followed for overlap routes.

#### 2.28.3 CRITERIA FOR LIMITED ACCESS ROADWAYS

Reference Location Signs and Enhanced Reference Location Signs shall be used on limited access facilities. The following criteria shall be used when selecting reference location signs along limited access facilities:

- (1) Reference location signs ([Section 2H.05 of the MUTCD](#)) shall be used every 1.0 mile outside urban boundary facilities.
- (2) Enhanced reference location signs ([Section 2H.06 of the MUTCD](#)) shall be used every half mile inside urban boundary facilities.

#### 2.28.4 CRITERIA FOR NON-LIMITED ACCESS ROADWAYS

- (1) While reference location signs will be helpful on many roadways, those with existing positioning systems, i.e., good building numbers, adequate landmarks, and signed cross streets will not benefit significantly. In addition, there may be many requests from municipalities to provide these signs on qualifying roadways. The following criteria shall be used when selecting roadways to use reference location signs:
  - (a) Cross at least two municipalities or two county jurisdictions within three miles.
  - (b) Relatively devoid of named landmarks, cross streets, or building addresses that would serve as navigation aids for motorists in the area.

- (c) Can be identified by local Emergency Medical Services (911) program to assist in address location.
  - (d) The proposed reference location sign should not interfere in any manner with other traffic control devices.
- (2) Requests for the reference location signing must be initiated by local jurisdictions. In all cases, requests shall be directed to the [DTOE](#) and must meet all the criteria listed above.
- (3) The local jurisdiction must, through the permit process, erect and maintain reference location signs on state system roadways, but the [DTOE](#) is responsible for the route signing plan.

## Section 2.29

### USE OF FLUORESCENT YELLOW-GREEN SIGN SHEETING

This section was rescinded on 11/1/18 and is now included in [Standard Specifications, Section 700](#).

## Section 2.30

### SIGNING FOR ONE-STOP CAREER CENTERS

#### 2.30.1 PURPOSE

The intent of this sign is to assist Floridians locate full-service One-Stop Career Centers located statewide. These centers provide a customer service network that offer every Floridian access to re-employment information, job search consulting, training and education referrals, and temporary financial assistance.

#### 2.30.2 BACKGROUND

In 1995, the State of Florida began taking steps toward a new future for workforce development. Florida has committed significant resources to the development and integration of its workforce development system, perhaps most significant is the development of the One-Stop Career Centers. These centers offer universal services to all Floridians, not just those eligible for specific programs.

#### 2.30.3 DEFINITIONS

**Full-Service One-Stop Career Center.** A physical location designated by the Regional Workforce Development Board which provides access to legislatively mandated partner agencies, and on-site delivery of core services, i.e., job search, placement assistance, skills assessment, and information on supportive services.

#### 2.30.4 SIGN DESIGN AND INSTALLATION

- (1) The One-Stop Career Center sign (**FTP-36-06**) shall be 36 x 36 inches and is white on green in color. The exact detail is shown in the [Standard Plans, Index 700-102](#).
- (2) Sign details are available in the [Department's Sign Library](#).
- (3) Sign requests must be submitted by a local representative of the [Workforce Regional Development Boards](#) to the appropriate [DTOE](#). The Department will only sign for full-service One-Stop Career Centers as defined above.
- (4) One-Stop Career Center signs will only be installed and maintained by the Department on Non-Limited Access Highways.
- (5) Signs will be placed, based on availability of suitable space, at the nearest intersection along the State Highway System to the One-Stop Career Center.
- (6) Mounting heights and lateral clearances shall adhere to those specified in the

[Standard Plans, Index 700-101](#) and support systems shall meet or exceed Department standards for frangibility.

## Section 2.31

### UNIQUE TRANSPORTATION SYMBOL SIGNS

#### 2.31.1 PURPOSE

To provide standards for the use of FHWA approved transportation symbol signs on the State Highway System.

#### 2.31.2 BACKGROUND

- (1) Florida has a unique traveler composition compared to other states, in that a significant proportion of motorists are not familiar with our roadways. This is mainly due to the very large number of tourists, both domestic and international.
- (2) We have found through research in our International Signing Study that non-familiar motorists respond very well to symbol signs.
- (3) We have enhanced our signing program by implementing the following innovative symbol signs that describe transportation related services or destinations.

#### 2.31.3 SCOPE

The use of the symbol signs in this section must meet the criteria for motorist services signing established in [Rule Chapter 14-51, F.A.C., Florida's Highway Guide Sign Program](#). More specifically, [Rule 14-51.021\(1\)\(f\), F.A.C.](#) for Limited Access Highways and [Rule 14-51.031\(1\)\(f\), F.A.C.](#) for Non-Limited Access Highways.

#### 2.31.4 PASSENGER SHIP SIGN

- (1) The passenger ship transportation mode forms an important destination for both Florida residents and visitors to the state. This symbol sign will be used throughout the state to trailblaze the routes to passenger seaports and cruise ship ports that meet criteria specified in **TEM 2.31.3**.
- (2) The PASSENGER SHIP sign (**Figure 2.31-1**) is a white symbol on green background.
- (3) A 30-inch sign panel should be used on limited access highways and a 24-inch panel on non-limited access highways.
- (4) Sign details are available in the [Department's Sign Library](#).

**Figure 2.31-1. Passenger Ship Sign**



### **2.31.5 AMTRAK SIGN**

- (1) This AMTRAK symbol sign is currently approved for use on guide signs and trailblazing to Amtrak stations.
- (2) Approval to place the AMTRAK sign shall be in accordance with criteria specified in **TEM 2.31.3**.
- (3) The AMTRAK sign (**Figure 2.31-2**) is a white symbol on green background.
- (4) A 30-inch sign panel should be used on limited access highways and a 24-inch panel on non-limited access highways.
- (5) Sign details are available in the [Department's Sign Library](#).

**Figure 2.31-2. Amtrak Sign**



### **2.31.6 GREYHOUND SIGNING**

- (1) This 3-color sign will be used as a motorist service sign and also to trailblaze to intra-city bus stations. Currently, there is no good way to sign for small bus stations that may be located within a building used for other businesses. The use of this symbol sign will make it easier to trailblaze to these locations.

- (2) Approval to place the GREYHOUND sign shall be in accordance with criteria specified in **TEM 2.31.3**.
- (3) The GREYHOUND sign is (**Figure 2.31-3**) a 3-color symbol with a white border on a green background
- (4) A 30-inch panel should be used on limited access highways and a 24-inch panel on non-limited access highways.
- (5) Sign details are available in the [Department's Sign Library](#).

**Figure 2.31-3. Greyhound Sign**

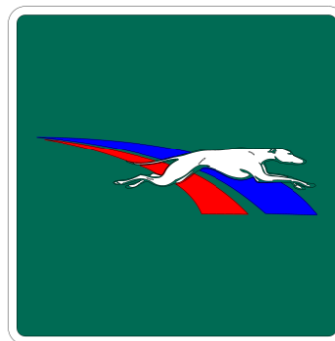

### **2.31.7 INSTALLATION AND PLACEMENT**

- (1) Where these signs are approved for use as trailblazer signs they shall be installed in accordance with height and lateral clearance requirements shown in the [Standard Plans, Index 700-101](#).
- (2) Where these signs are approved for use as general service signs appended to freeway guide signs, they must conform to the [Standard Plans, Index 700-104](#) except for color scheme.

## Section 2.32

### 511 TELEPHONE SERVICE SIGN

#### 2.32.1 PURPOSE

The 511 Telephone Service is part of a nationwide program where motorists who wish to obtain traffic and transportation information can do so by dialing 511 from either their cell or regular phones in areas where the service is available. Signs will be erected to inform motorists of the phone number for this service.

The signing will extend to all Interstate and major State Highway System roadways throughout the state that have the 511 Telephone Service.

#### 2.32.2 SIGN DESIGN AND PLACEMENT

- (1) The CALL 511 sign (*Figure 2.32-1*), as found in [Section 2I.10 of the MUTCD](#), has two standard sizes. Signs installed on limited access highways shall be 48 x 60 inches (*FTP-66-06*) while signs installed on non-limited access highways shall be 36 x 48 inches (*FTP-67-06*).

Figure 2.32-1. TRAVEL INFO CALL 511 Sign



- (2) The CALL 511 signs (*FTP-66-06 and FTP 67-06*) shall have a white legend on blue background and the exact sign details are shown in the [Standard Plans, Index 700-102](#).
- (3) Sign details are available in the [Department's Sign Library](#).

- (4) When the 511 Telephone Service becomes available, specific sign placement details shall be reviewed by the appropriate [District Traffic Operations Office](#) using the guidelines shown in **TEM 2.32.2.1** and **TEM 2.32.2.2**.

### **2.32.2.1 Interstate and Other Limited Access Routes**

- (1) At state and county lines
- (2) At approximately 10 mile intervals in urban/metro areas
- (3) At approximately 30 mile intervals in rural areas
- (4) Preceding major freeway to freeway interchanges

### **2.32.2.2 Major Arterial Routes**

- (1) At state and county lines
- (2) At approximately 10 mile intervals in urban/metro areas
- (3) At approximately 30 mile intervals in rural areas
- (4) Recommended locations should be upstream from intersections formed by junctions of U.S./Major State Highway System Roadways at the discretion of the [DTOE](#).

## Section 2.33

# SIGNING FOR NATURE-BASED TOURISM AND HERITAGE TOURISM TRAILS

### 2.33.1 PURPOSE

The purpose of this section is to identify for prospective sponsors of nature-based and/or heritage trails the type of support the Department can offer and the signs that are appropriate for installing along public roadways.

### 2.33.2 BACKGROUND

- (1) The concept of nature-based and heritage tourism is best explained as a statewide effort to promote the natural and historic resources of our state. These resources include natural spaces of our State Parks, lakes, rivers, beaches, and woodlands, as well as the rich historical and cultural sites across Florida.
- (2) The Department is an active participant in the effort to promote Florida's natural assets through nature-based tourism and heritage tourism programs. The Department's role is to provide a mechanism for using public right of way for the needed signs and provide engineering guidance to ensure that effective signing plans are developed.
- (3) Some examples of approved trails are the Historic Heritage Trail sponsored by the Department of State, the Birding Trail sponsored by the Fish and Wildlife Conservation Commission, and the Gulf Coast Heritage Trail sponsored by the Sarasota Bay National Estuary Program.

### 2.33.3 PILOT PROGRAM

- (1) The Gulf Coast Heritage Trail was the first regional nature-based tourism trail program within the state and the Department approved the signing plan as a pilot program. It is a true trail system in that trail-blaze signs identify the route to follow to access the sites, which are also described in the auto tour map and brochure. The program was pioneered and coordinated by the Sarasota Bay National Estuary Program in Sarasota and Manatee Counties.
- (2) The success of this pilot is such that the Department is using the Gulf Coast Heritage Trail as a model for other regional plans to follow.

### 2.33.4 CRITERIA FOR SIGNING PROGRAM

In developing a trail system, several criteria must be followed by the sponsor of the proposed nature-based or heritage tourism trail.

- (1) The sponsor must develop grassroots support including local input into establishing routes.
- (2) The program must include use of a land-based brochure with auto tour map - the signs are not the primary guidance method.
- (3) Attraction selection should be restricted to public ownership, non-profit, or for those charging admission, a primary educational purpose (this includes museums and art galleries).
- (4) Promotional posters and an Internet website are strongly suggested.

### **2.33.5 DOT PARTICIPATION**

- (1) The Department will participate in the development of nature-based and heritage tourism programs by providing advisory services as the programs are proposed, offer preliminary route recommendations, and approve routes upon which signs may be erected.
- (2) The Department's [State Traffic Engineering and Operations Office](#) (850-410-5600) must be contacted early in the process to assure proper coordination with all districts affected by the proposed trail.
- (3) Upon selection of the final route, the District Traffic Operations personnel will determine appropriate locations for trail-blaze signs and mark the locations so that a sign contractor can erect the signs. It is the sponsor's responsibility to have the signs manufactured and erected through the Department's general use permitting process. Department staff can provide the names of sign manufacturers and contractors who are experienced in providing these services.

### **2.33.6 SIGN APPROVAL AND DESIGN**

- (1) The [STOE](#) in Tallahassee must approve the sign design to be used for this program.
- (2) Logo signs are encouraged for this program, and several criteria apply:
  - (a) Signs installed on non-limited access highways shall be 24-inch panels. The name of the trail should be in white highway sign type, upper case lettering (Helvetica). A sample logo is shown in **Figure 2.33-1**.
  - (b) Signs shall be devoid of advertising.
  - (c) Signs logos may use colors, but must contain a brown background of Type III retro-reflective sheeting, per [Standard Specifications, Section 994](#). Inks must be transparent highway sign types.
  - (d) Signs should be installed along the State Highway System route with an

arrow pointing in the appropriate direction where cross streets must be used to access the attraction. Confirmation signs, with straight-ahead arrows, are used at appropriate intervals to let motorists know they are on the right path (usually 3-5 miles depending upon length of the route segments).

**Figure 2.33-1. Logo for Gulf Heritage Trail**



### **2.33.7 SIGN MAINTENANCE**

- (1) The sponsors of the proposed nature-based and/or heritage trails are responsible for the maintenance of the signs used throughout the trail.
- (2) A contract with a private sign installation contractor should be executed or a maintenance agreement with local government secured for signs on the State Highway System.
- (3) Evidence of the contract or agreement must be presented to the appropriate [District Traffic Operations Office](#) prior to installation of the signing program.

## Section 2.34

# SIGNING FOR THE FLORIDA SCENIC HIGHWAYS PROGRAM AND THE NATIONAL SCENIC BYWAYS PROGRAM

### 2.34.1 PURPOSE

To establish statewide signing standards for designated Florida Scenic Highways and/or National Scenic Byways.

### 2.34.2 BACKGROUND

- (1) The intent of both the Florida Scenic Highways Program (FSHP) and the National Scenic Byways Program (NSBP) is to designate paved public roads as scenic corridors to preserve, enhance, and maintain the intrinsic resources for the enjoyment of the traveling public.
- (2) For a roadway to be designated under either or both these programs, the roadway must possess at least one of the following six intrinsic resources:
  - (a) **Cultural Resources.** Include the traditions, values, customs and arts of social groups.
  - (b) **Historical Resources.** Reflect human actions evident in past events, sites or structures.
  - (c) **Archaeological Resources.** Embody the physical evidence or remains of human life, activities, or cultures.
  - (d) **Recreational Resources.** Highlight activities dependent upon the natural elements of the landscape.
  - (e) **Natural Resources.** The natural landscapes showing little or no-disruption by humans.
  - (f) **Scenic Resources.** Combinations of natural and manmade features that give the visual landscape remarkable character and significance.
- (3) Benefits of designation as a Florida Scenic Highway and/or a National Scenic Byway include:
  - (a) **Resource Protection.** FSHP/NSBP designation provides the opportunity to preserve and enhance the significant intrinsic resources along public roads.

- (b) **Community Recognition.** The posting of the FSHP/NSBP logo signage along the designated highways will identify the corridors as “special places” with important resources worth noting.
- (c) **Economic Development/Tourism.** Designation provides an opportunity for the millions of tourists traveling by car in Florida to visit these communities along a designated highway corridor.
- (d) **Community Visioning.** The FSHP/NSBP designation can complement and support a community’s vision thereby instilling a sense of pride.
- (e) **Partnering.** This concept comes from public and private cooperation of agencies and corporate sponsorships, which provide support to the community and the overall corridor’s focus.

### 2.34.3 PROGRAM COORDINATION

- (1) FDOT’s [Environmental Management Office \(EMO\)](#) oversees the Statewide Florida Scenic Highways Program.
- (2) Each FDOT District Office has a designated District Scenic Highways Coordinator that represents the district in all matters pertaining to the FSHP or NSBP. The District Scenic Highways Coordinators are the initial point of contact for questions about the Program and provide the link between the Department and the community.

### 2.34.4 SIGN CRITERIA

- (1) In signing a designated Florida Scenic Highway (FSH) or National Scenic Byway (NSB), the following criteria must be followed:
  - (a) Signing shall not interfere with or distract from adjacent traffic control devices or from the resources of the area.
  - (b) Signing shall conform to the [MUTCD](#), which is incorporated by reference in [Rule 14-15.010, F.A.C.](#)
  - (c) Highways that lose designation under the FSHP or the NSBP shall have all FSH and NSB signs removed.
- (2) Designated FSH, and NSB (as applicable), shall be signed at entrance points to a route. Signing along a designated highway will be installed approximately every five miles in both directions. However, during the review by District Traffic Operations, exceptions can be made based on frequency of intersections and/or directional needs.

- (3) Signs shall be installed for both FHS and NSB in accordance with the approved sign standards shown in **TEM 2.34.5** and **TEM 2.34.6**.

## **2.34.5 FLORIDA SCENIC HIGHWAY SIGNS**

### **2.34.5.1 COORDINATION**

- (1) The Department of Transportation provides advisory services when highway corridors are proposed for eligibility or designation to the FSHP. Once the highway corridor is designated, the District Scenic Highway Coordinator(s) facilitates the coordination of the sign implementation process.
- (2) The proper sign coordination process for a FSH is detailed below:
- (a) The District Coordinator(s) will coordinate the preferred location(s) for the FSHP signs with the [District Traffic Operations Office](#), along with the Corridor Management Entity (CME).
  - (b) The [District Traffic Operations Office](#) will finalize the location(s) of the signs and send a work request to the appropriate District Maintenance Yard for installation.
  - (c) One additional sign will be ordered along with all the other signs. This sign is to be used as a display at the ceremony and is not to be placed along the corridor.
  - (d) The CME and its partners may host a dedication ceremony to celebrate the designation of the particular corridor as a Florida Scenic Highway.

### **2.34.5.2 SIGN DETAIL**

- (1) The standard sign design to be used to designate a Florida Scenic Highway is shown in **Figure 2.34-1**. There are two sign sizes available, and they are to be used in the specific applications shown in **TEM 2.34.5.3**.
- (2) Sign details are available in the [Department's Sign Library](#).

### **2.34.5.3 SIGN INSTALLATION**

- (1) The 24 x 36 FSH sign (**Figure 2.34-1**) shall be installed at the entrance points to a designated Florida Scenic Highway route along with a supplemental panel with the scenic highway's name.

**Figure 2.34-1. Florida Scenic Highway Sign Design**



- (2) When appropriate, the Florida Scenic Highway Sign shall be co-located with existing route confirmation signs. The 16 x 24 sign panel should be installed on top of this sign. The exact application is shown in **Figure 2.34-2**.

**Figure 2.34-2. Co-Location on Route Confirmation Marker**



- (3) When the designated scenic highway intersects with another state road, the 16 x 24 sign panel should be installed on existing route directional signs. The exact application is shown in **Figure 2.34-3**.
- (4) The Department is responsible for the installation of the FSH signs on the State Highway System.
- (5) The local government is responsible for the installation of the FSH signs on their system.

#### **2.34.5.4 MAINTENANCE**

- (1) The maintenance of the FSH signs used throughout the scenic highway corridor depends on the government entity that is responsible for the roadway.

- (a) The Department is responsible for the maintenance of FSH signs on the State Highway System.
- (b) Local government is responsible for the maintenance of FSH signs on their roads.

**Figure 2.34-3. Co-Location on Route Direction Marker**



## 2.34.6 NATIONAL SCENIC BYWAY SIGNS

### 2.34.6.1 COORDINATION

- (1) The Department provides advisory services when highway corridors are proposed for eligibility or designation to the NSBP. Once the highway corridor is designated, the District Scenic Highway Coordinator(s) facilitates the coordination of the sign implementation process similar to the FSH process outlined in **TEM 2.34.5.1**. The only difference will be no need for an extra NSB sign panel for the dedication ceremony.
- (2) The District Scenic Highways Coordinator(s) will work with the Statewide Scenic Highways Coordinator to submit applications for National Scenic Byway or All-American Road designation to the Federal Highway Administration.
- (3) Once designated as National Scenic Byway or All-American Road, the District Scenic Highway Coordinator(s) will facilitate the following process.

- (a) The District Scenic Highway Coordinator(s) will coordinate the location of the NSBP signs with the [District Traffic Operations Office](#).
- (b) District Traffic Operations will locate the signs and send a work request to the appropriate District Maintenance Yard for installation.
- (c) The District Scenic Highway Coordinator(s) will contact the respective District Maintenance Office or local government to coordinate the installation of the signs along the corridor.

### 2.34.6.2 SIGN DETAIL

- (1) The FHWA developed and approved the *America's Byways (D6-4 and D6-4a)* sign shown in [Section 2D.55 of the MUTCD](#). This sign is approved for use on National Scenic Byways.
- (2) The exact sign details for the National Scenic Byways Sign can be found in the FHWA's [Standard Highway Signs Manual](#).

### 2.34.6.3 INSTALLATION

- (1) The NSB sign shall be installed at the entrance points to a designated byway. When possible, this sign shall be mounted below the FSH sign on a standard sign pole.
- (2) When an existing designated Florida Scenic Highway becomes a National Scenic Byway, District Traffic Operations will review the existing signing on the designated roadway for possible ways to accommodate both designations on the corridor. If unable, to place both, then the FSH will have the priority on the roadway.
- (3) The Department is responsible for the installation of the NSB signs on the State Highway System.
- (4) The local government is responsible for the installation of the NSB signs on their system.

### 2.34.6.4 MAINTENANCE

- (1) The maintenance of the NSB signs used throughout the National Scenic Byway corridor depends on the government entity that is responsible for the roadway.
  - (a) The Department is responsible for the maintenance of the NSB sign on the State Highway System.
  - (b) Local government is responsible for the maintenance of the NSB sign on their roads.

## Section 2.35

### SIGNING FOR MEMORIAL ROADWAY DESIGNATIONS

#### 2.35.1 PURPOSE

The purpose of this section is to provide guidance to the districts on the installation of signs when a roadway has been given a memorial designation by the Florida Legislature.

#### 2.35.2 BACKGROUND

- (1) Over the years, the Florida Legislature has dedicated, named, and otherwise titled roadways in Florida. The designated roads can be under the jurisdiction of either the Department or local government.
- (2) Records kept in the Department's Systems Implementation Office identify the earliest dedicated roadway as the W.W. Clark Memorial Bridge on State Road 580 between Safety Harbor and Oldsmar. This was dedicated by the State Road Board on July 6, 1922. Since that time, every county and most cities have participated in officially naming some roadway feature.

#### 2.35.3 SIGNING PROCESS

- (1) The Florida Legislature designates the roadways based on recommendations from a city or county commission, individual state agencies, or civic groups.
- (2) Upon official designation by the Florida Legislature, it is the responsibility of the legislative sponsors of the designation to obtain local resolutions in accordance with [Section 334.071\(3\), F.S.](#)
- (3) After receiving a copy of the local resolution, the Department shall begin the process to have the signs installed on the State Highway System.
- (4) Within the Department, the process for the installation of these signs involves the following offices:
  - (a) District Public Information Office
  - (b) [District Traffic Operations Office](#)
  - (c) District Maintenance Office
  - (d) [State Traffic Engineering and Operations Office](#)
  - (e) Transportation Data and Analytics Office

- (5) Each district has their own signing process in place, and it varies as to which of the above district offices initiates the process. However, it is important that all the above district offices are notified and kept informed as to the status of roadway designations within their district after each legislative session.
- (6) Each district will coordinate the installation of the signs with the legislative sponsor of the designation.
- (7) Memorial names may not appear on guide signs or on any other than the standard sign, in accordance with [Section 2M.10 of the MUTCD](#).

#### 2.35.4 SIGN INSTALLATION AND MAINTENANCE

- (1) Signs shall be installed and maintained by the Department on the State Highway System.
- (2) On non-limited access facilities, one sign per direction shall be installed in accordance with [Section 2M.10 of the MUTCD](#).
- (3) On limited access facilities, one sign per direction shall be installed in accordance with [Section 2M.10 of the MUTCD](#).

#### 2.35.5 SIGN DESIGN

- (1) The signs used for Memorial Roadway Designations shall be a brown panel with yellow lettering. An example of this sign is shown in **Figure 2.35-1**.

**Figure 2.35-1. Memorial Roadway Designation Sign**



- (2) Sign details are available in the [Department's Sign Library](#).

## Section 2.36

### COMMUNITY WAYFINDING GUIDE SIGNS

#### 2.36.1 PURPOSE

The purpose of this section is to provide guidance to the districts on the process for approving Community Wayfinding Guide Signs on the State Highway System.

#### 2.36.2 BACKGROUND

- (1) The Department, in cooperation with the Florida League of Cities, has developed statewide criteria for Community Wayfinding Guide Signs on our State Highway System. These standards as shown in [Rule 14-51. Part V. F.A.C.](#) (Florida's Highway Guide Sign Program) provide local governments the flexibility to design their own Community Wayfinding Guide Sign System while still maintaining federal and state sign standards to safely guide motorists to their destinations.
- (2) The standards shown in [Rule 14-51. Part V. F.A.C.](#) allow local governments to have a better understanding of what can and cannot be approved for use on the State Highway System based on the requirements of the MUTCD.

#### 2.36.3 STANDARDS

- (1) All Community Wayfinding Guide Signs on the State Highway System must be in conformance with [Rule 14-51. Part V. F.A.C.](#) prior to any installation.
- (2) In conformance with [Rule 14.51.051\(8\). F.A.C.](#), the design, installation, and maintenance of Community Wayfinding Guide Signs on the State Highway System are the responsibility of local government.

#### 2.36.4 REVIEW PROCESS

- (1) A pre-planning meeting between District Traffic Operations and local government is recommended to assist in compliance with [Rule 14-51. Part V. F.A.C.](#)
- (2) After a Community Wayfinding Guide Sign System Plan has been developed, local governments or their representative must provide one set of the Community Wayfinding Guide Sign System Plans to the appropriate [District Traffic Operations Office](#).
- (3) Once received, the Community Wayfinding Guide Sign System Plan shall be reviewed by the [District Traffic Operations Office](#) for compliance with [Rule 14-51. F.A.C.](#)

- (4) If compliance is not met, District Traffic Operations staff will contact local government with the changes that need to be made to their Community Wayfinding Guide Sign System Plan in order to meet the criteria shown in the [Rule 14-51. F.A.C.](#)
  
- (5) Once the Community Wayfinding Guide Sign System Plan is approved, the [District Traffic Operations Office](#) shall issue a letter of compliance signed by the [DTOE](#) to the local government.

## Section 2.37

### ADVANCE STREET NAME SIGNS

#### 2.37.1 PURPOSE

To provide guidance on the design, placement, and installation criteria for advance street name signs on the State Highway System.

#### 2.37.2 BACKGROUND

- (1) The use of advance street name signs is one of the recommended roadway improvements and safety countermeasures in the Department's Safe Mobility for Life Program. This recommended improvement is based on the [FHWA's Handbook for Designing Roadways for the Aging Population](#) to provide advance notification to drivers to help them in making safer roadway decisions.
- (2) In 2002, FDOT conducted an effectiveness study on the roadway improvements that were implemented in our aging road user program, including advance street name signs. Data from that study showed that advance street name signs with larger lettering were read at a greater distance from the intersection being announced which led to significantly more decision time. The research supports our decision to continue to use advance street name signs as an effective safety countermeasure for FDOT's [Safe Mobility for Life Program](#).

#### 2.37.3 DEFINITIONS

**Critical or Significant Cross Street.** A signalized or unsignalized intersection or cross street classified as a minor arterial or higher, that provides access to a traffic generator or possesses other comparable physical or traffic characteristics deemed to be critical or significant and having an AADT greater than 2000.

#### 2.37.4 STANDARDS

The standards shown in this section apply to each of the three different types of advance street name sign applications. Specific criteria for the installation of advance street name signs at signalized intersections (NEXT SIGNAL) is shown in **TEM 2.37.5**, for non-signalized intersections (NEXT INTERSECTION) in **TEM 2.37.6** and for advance street name plaques on intersection warning signs in **TEM 2.37.7**.

- (1) Advance street name signs and Advance Street Name plaques shall only be used to identify critical or significant cross streets. They are not intended to identify destinations such as cities, facilities, or residential neighborhoods.

- (2) Whenever possible the word Street, Boulevard, Avenue, etc., should be abbreviated (St, Blvd, Ave) or letter height reduced to conserve sign panel length. In special cases it may be deleted; however, if confusion would result due to similar street names in the area, for example Orange Street and Orange Avenue, this deletion should not be made.

When a subdivision or community in the area also goes by that name these words (Street, Boulevard, Avenue, etc.) or their abbreviations should not be deleted.

- (3) When a cross street is known by both route number and a local name, use of the local name is preferred on the advance street name sign since the route number is identified on route markers along the route.
- (4) When minor cross streets intersect the State Highway between the advance street name and the intersection, additional legend such as NEXT SIGNAL or XX FEET may be added to the advance street name sign.
- (5) The legend used on the advance street name sign or plaque shall be consistent with the legend on either the overhead street name or post mounted street name sign.
- (6) Sign sheeting materials shall comply with the current edition of the [Standard Specifications, Section 994](#).
- (7) Mounting heights and lateral clearances should adhere to those specified in the [Standard Plans, Index 700-101](#) and support systems shall meet or exceed Department standards of frangibility.
- (8) Signs should be installed in advance of the intersection in accordance with the distances shown in ["Condition A" of Table 2C-4 of the MUTCD](#). These distances are to be considered the minimum for a single lane change maneuver and should be measured from the begin taper point for the longest auxiliary lane designed for the intersection. The degree of traffic congestion and the potential number of lane change maneuvers that may be required should also be considered when determining the advance placement distance.

### **2.37.5 ADVANCE STREET NAME SIGNS AT SIGNALIZED INTERSECTIONS**

- (1) Requests to install advance street name signs (**Figure 2.37-1**) must be initiated by District Traffic Operations or based on a request received from the local agency having jurisdiction over the approaching cross street. The [DTOE](#) is responsible for the review and approval of these signs.
- (2) Advance street name signs shall be white lettering on green background and designed in accordance with [Section 2D.05](#) and [Section 2D.39 of the MUTCD](#).

**Figure 2.37-1. Advance Street Name Sign at Signalized Locations**



- (3) The use of advance street name signs at signalized intersections as a safety countermeasure are recommended and should be installed if any of the following conditions occur:
- (a) There is a documented history of side-swipe or rear-end crashes or;
  - (b) There are high volume approaches.
  - (c) There is a high 65 and older population.
  - (d) Roadway with 4 lanes or greater.
  - (e) Rural high speed roadways (50 mph or greater).
  - (f) The intersection is located in a [Safe Mobility for Life Coalition Priority County](#).
- (4) At a minimum, letter height (legend) shall conform to **Table 2.37-1, Design Guidelines for Advance Street Name Signs**. When street name legends are lengthy, or there is limited right-of-way the sign font shall be modified from **Table 2.37-2** using the standard font sizes shown in **Figure 2.37-4**.

**Table 2.37-1. Design Guidelines for Advance Street Name Signs**

Posted Speed Limit	STREET NAME LEGEND	NEXT SIGNAL or NEXT INTERSECTION
	Letter Size (inches) Upper/Lower Case Letters	Letter Size (inches) Upper Case Letters
35 mph or less	8EM	6D
40 mph or greater	10.67EM	8E

- (5) Roadways posted at 35 mph or less, or when limited right of way is available a single post sign design (**Figure 2.37-2**) shall be installed.

**Figure 2.37-2. Advance Street Name Sign Design (Single Post)**



- (6) Roadways posted at 40 mph or greater and have no limited right of way, a double post design (**Figure 2.37-3**) shall be installed.

**Figure 2.37-3. Advance Street Name Sign Design (Double Post)**



**Figure 2.37-4. Standard Font Sizes for Advance Street Name Sign Legends**

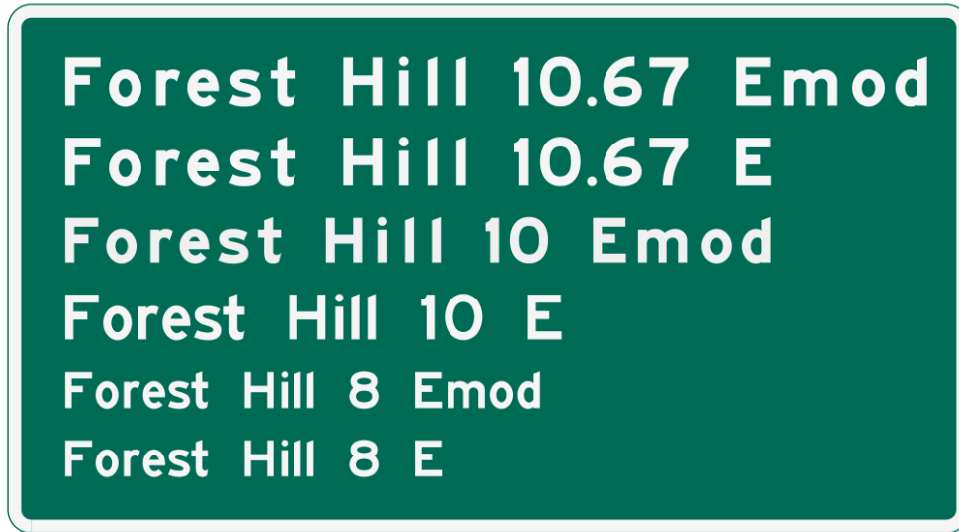

- (7) When a cross street has a different name on each side of the intersection, both names shall be shown on the advance sign with an arrow beside each name to designate direction (*Figure 2.37-5*).

**Figure 2.37-5. Advance Street Name Sign Using Different Names**



### **2.37.6 ADVANCE STREET NAME SIGNS AT NON-SIGNALIZED INTERSECTIONS**

- (1) Requests to install advance street name signs (*Figure 2.37-6*) at non-signalized intersections must be initiated by District Traffic Operations or based on a request received from the local agency having jurisdiction over the approaching cross street. The [DTOE](#) is responsible for the review and approval of these signs.
- (2) These signs may be installed on multi-lane divided highways that have a

dedicated left turn lane, not just a median opening for the approaching critical or significant cross street. The posted speed of the roadway shall not be lower than 45 mph.

- (3) Advance street name signs shall be designed in accordance with [Section 2D.05](#) and [Section 2D.39 of the MUTCD](#) and the [Standard Highways Signs Manual](#).
- (4) At a minimum, letter height (legend) shall conform to **Table 2.37-1, Design Guidelines for Advance Street Name Signs**.

**Figure 2.37-6. Advance Street Name Signs at Non-Signalized Locations**



### **2.37.7 ADVANCE STREET NAME PLAQUES ON INTERSECTION WARNING AND ADVANCE TRAFFIC CONTROL SIGNS**

- (1) Intersection Warning Signs (**W2** series) (**Figure 2.37-7**) and Advance Traffic Control Signs (**W3** series) (**Figure 2.37-8**) should be installed when there is a documented need based on sight restriction, crash history, or engineering judgment.
- (2) Advance street name plaques ([Section 2C.49 of the MUTCD](#)) should be installed on these warning signs when there is:
  - (a) Minimum of 2000 AADT
  - (b) No street lighting along main arterial
  - (c) Documented history of turning, entering, or side-swipe crashes
  - (d) Limited sight distance due to horizontal or vertical curves
  - (e) A high 65 and older population
  - (f) The intersection is located in a [Safe Mobility for Life Coalition Priority County](#).

- (3) It is recommended that wherever a new or replacement Intersection Warning Sign (**W2** series) is installed on a rural roadway it is accompanied by an advance street name plaque designed in accordance with this section.
- (4) Requests must be initiated by District Traffic Operations or may also be received from the local agency having jurisdiction over the approaching cross street.
- (5) Advance street name plaques shall be black lettering on yellow background using an 8-inch D series lettering size mounted below a 48-inch warning sign panel, with upper/lower case lettering in accordance with the [FHWA's Handbook for Designing Roadways for the Aging Population](#). If not structurally possible, lettering size may be decreased to a minimum of 5-inch D series.
- (6) Roads not currently signed with an advance route marker may be considered for an Intersection Warning Sign (**W2** series) with an advance street name plaque when they meet the criteria referenced in **TEM 2.37.7(1)**.
- (7) Roads with an advanced route marker (JCT shield) (**Figure 2.37-9**) may have the street name plaque placed below to better identify the roadway to unfamiliar travelers. The panel color should match the route marker. If used, the lettering on the street name plaque shall be no less than 4-inch C series.

**Figure 2.37-7. Advance Street Name Plaque on Intersection Warning Sign**



**Figure 2.37-8. Advance Street Name Plaque on Advance Traffic Control Warning Sign**



Figure 2.37-9. Advance Street Name Plaque on Advanced Route Marker



## Section 2.38

### USE OF GENERATORS AND PORTABLE STOP SIGNS AT NON-FUNCTIONING SIGNALIZED INTERSECTIONS

#### 2.38.1 PURPOSE

The purpose of this section is to provide guidance on deploying generators and portable stop signs at non-functioning signalized intersections after an emergency event. The Department's guiding principles on deploying generators and portable or part-time (folding) stop signs shall conform to [Section 316.1235, F.S.](#) and to the [MUTCD](#).

#### 2.38.2 CONDITIONS FOR USE

- (1) The [DTOE](#) shall request the installation of generators or the placement of portable stop signs after an emergency event at locations where a signalized intersection is not functioning. A non-functioning signalized intersection is defined herein as an intersection that is equipped with traffic signals which are damaged and/or without power after an emergency event.
- (2) When the signalized intersection is without power and restoration of power using a generator is not possible, portable stop signs should be placed as directed by the [DTOE](#).
- (3) When portable stop signs are utilized at a signalized intersection that is not functioning due to a power outage, the power shall be disconnected to avoid traffic control conflicts when power is restored.
- (4) When generators are used at a signalized intersection due to a power outage and power is restored, the traffic signals shall continue to function in the same operation. If the traffic signals were in flashing operation, the traffic signals shall continue in flashing operation. If the traffic signals were in normal cycle and phasing operations, the traffic signals shall continue in the normal operation.

#### 2.38.3 LOCATION AND PLACEMENT

- (1) The locations for placement of generators or portable stop signs shall be at the discretion of the [DTOE](#). They shall, in coordination with local agencies, develop and maintain a list of critical signalized intersections to establish a priority for generator or portable stop sign installation.
- (2) The placement of the portable stop signs shall be in accordance with **Figures 2.38-1 through 2.38-6** of this section. Placement of the portable stop signs for any intersection design not represented in **Figures 2.38-1 through 2.38-6** shall be done in accordance with the direction of the [DTOE](#), the [Standard Plans](#), and

the [MUTCD](#).

- (3) Each critical signalized intersection control cabinet shall be wired with a transfer switch and capable of switching to an alternate generated power source in the event of a power outage and shall conform to [Standard Specifications, Section 676](#).

#### **2.38.4 STORAGE AND DISTRIBUTION**

- (1) Each District shall have access to and be capable of deploying portable generators to provide an alternate power source to 12 percent of the signalized intersections on the State Highway System in the District. The District Maintenance Office shall determine the deployment locations.
- (2) The District Maintenance Office shall be responsible for maintenance and storage of the generators.
- (3) Each District shall have access to and be capable of deploying portable stop signs to non-functioning signalized intersections on the State Highway System in the District that are not equipped with a generator.

#### **2.38.5 REMOVAL AND RECOVERY**

- (1) The generators should be removed upon restoration of power and proper signals operation. The portable stop signs should be removed prior to normal operations of the traffic control signal. The recovery of the generators and portable stop signs should be accomplished using District emergency response teams or emergency contractors by either of the following:
  - (a) Complete removal from each intersection.
  - (b) Stockpiling the portable stop signs in one corner of the intersection for removal later.
- (2) The Districts shall determine the method of recovery and develop a recovery plan for their intersections.

**Figure 2.38-1. Temporary Signing for Power Outage – Major Dual Left Intersection**

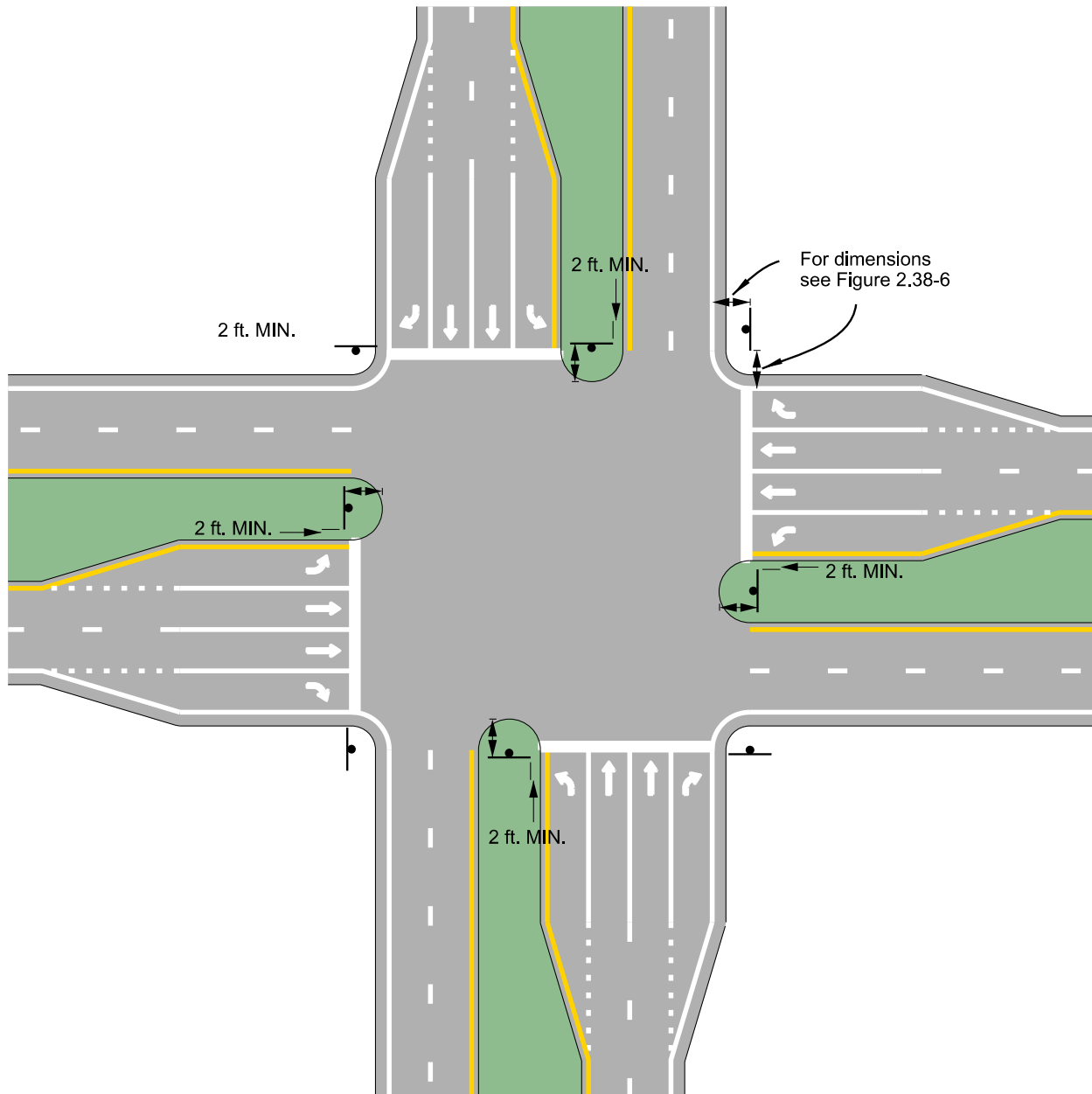

**Figure 2.38-2. Temporary Signing for Power Outage – Major Single Left Intersection**

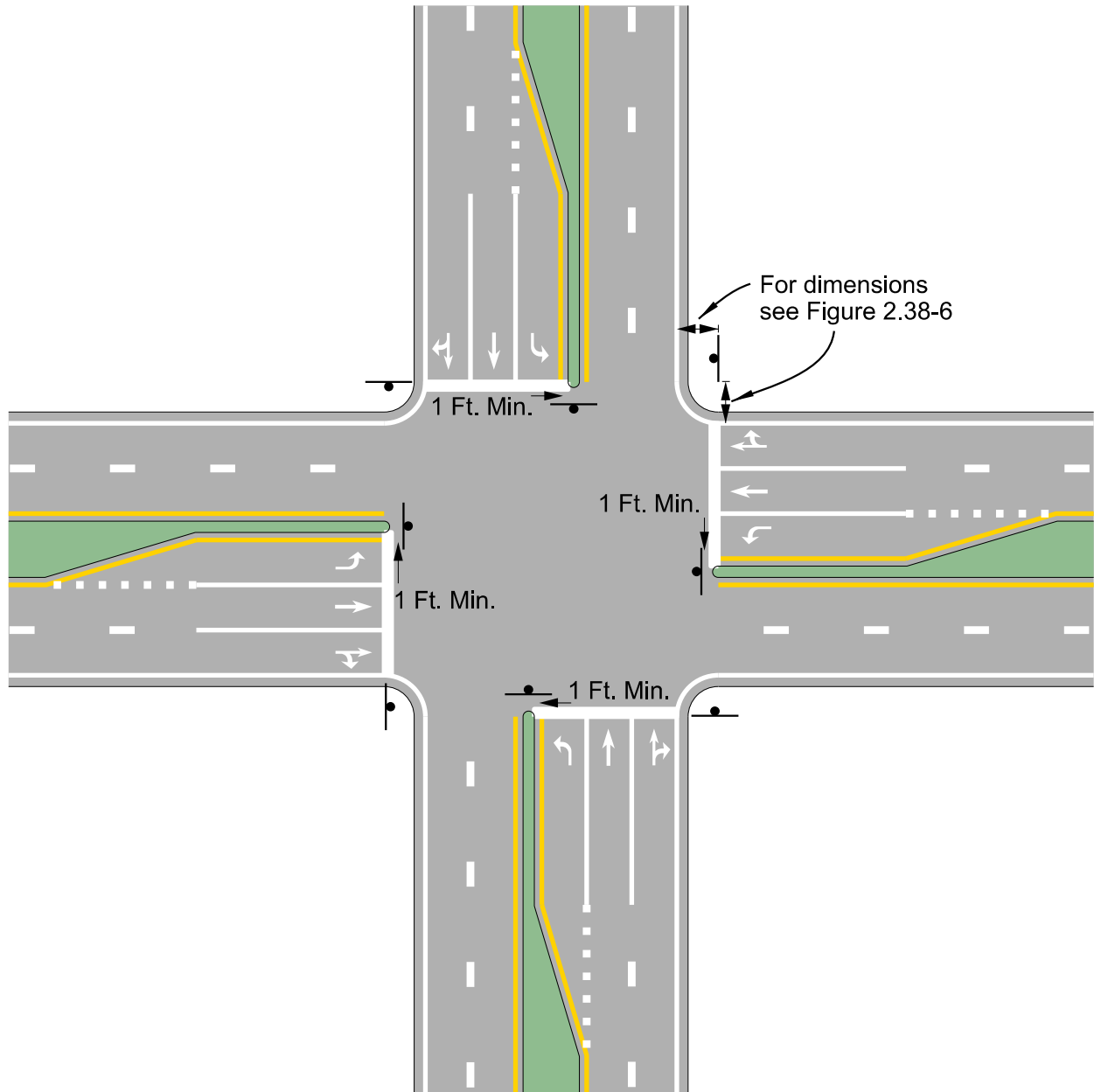

**Figure 2.38-3. Temporary Signing for Power Outage – Major Thru Intersection**

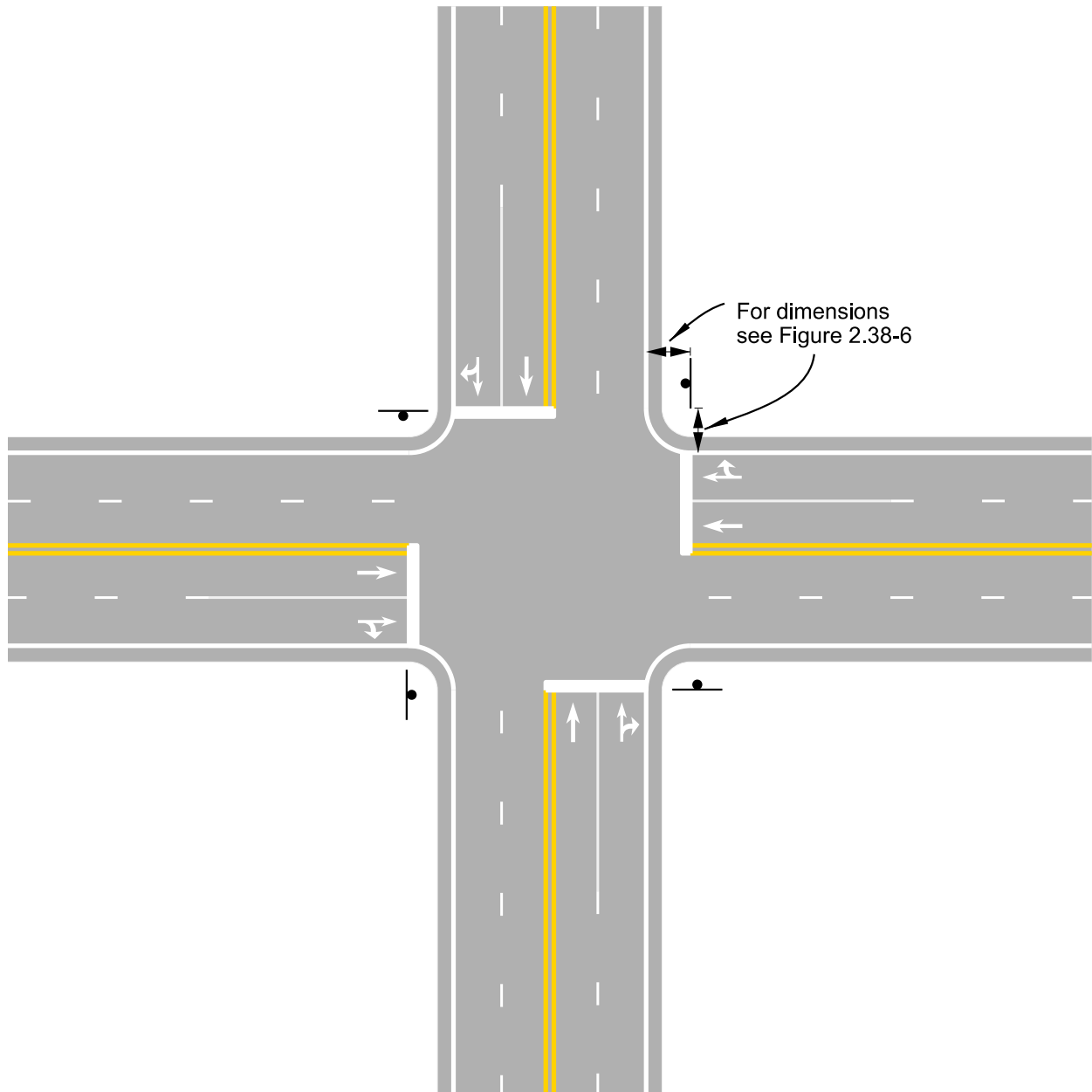

**Figure 2.38-4. Temporary Signing for Power Outage – Major to Minor Intersection**

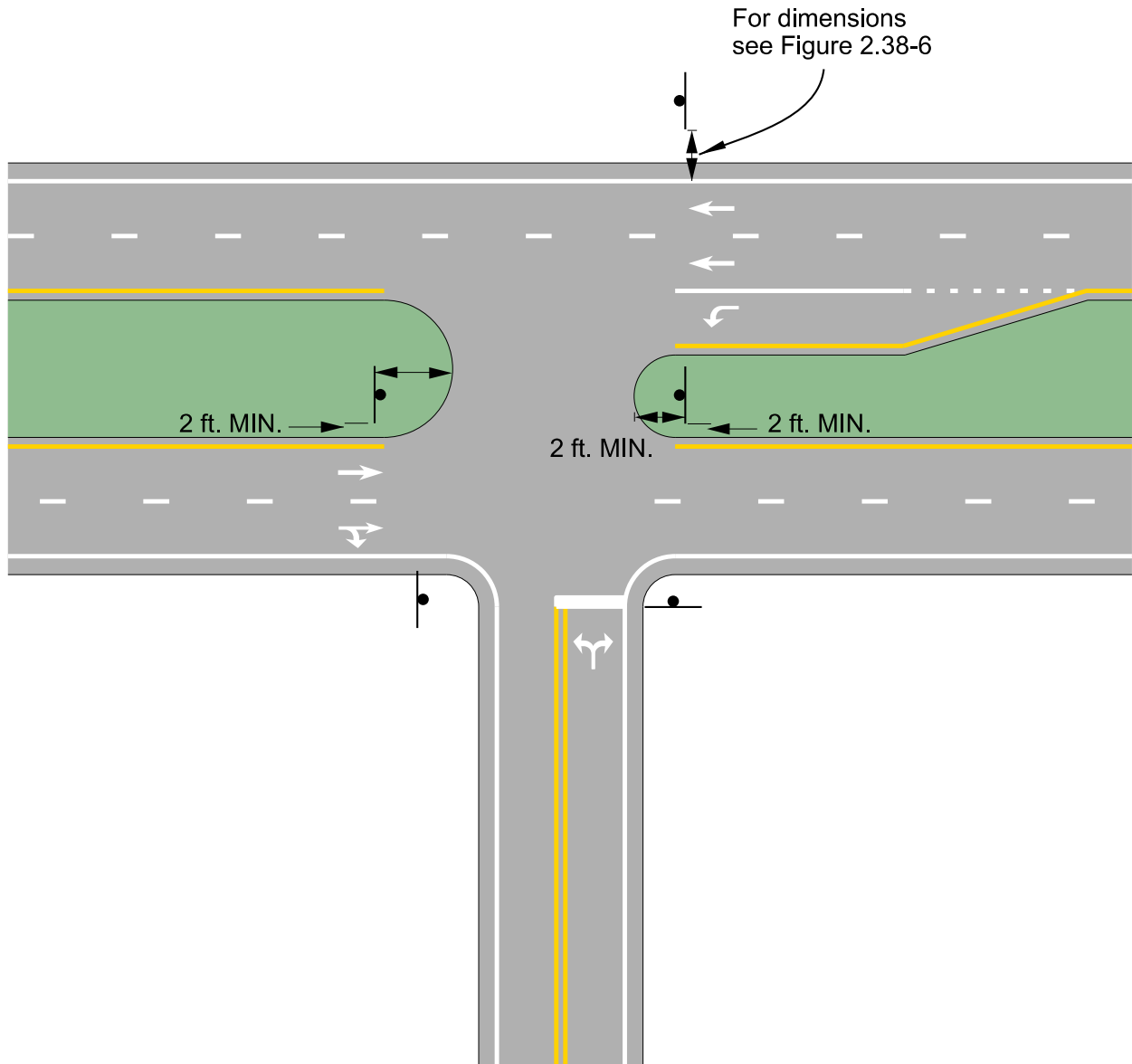

**Figure 2.38-5. Temporary Signing for Power Outage – Minor Intersection**

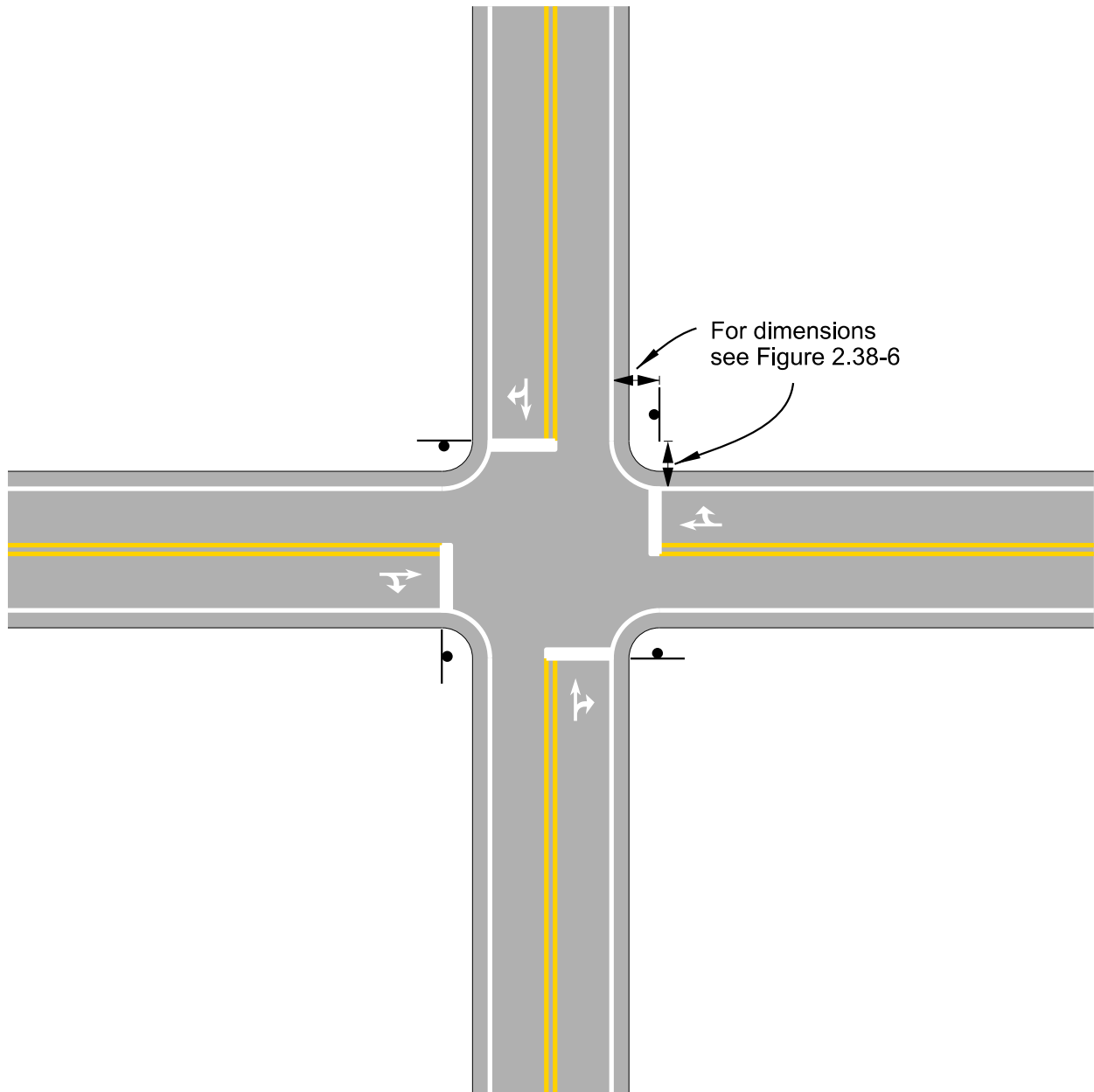

**Figure 2.38-6. Temporary Signaling for Power Outage – Sign Dimensions**

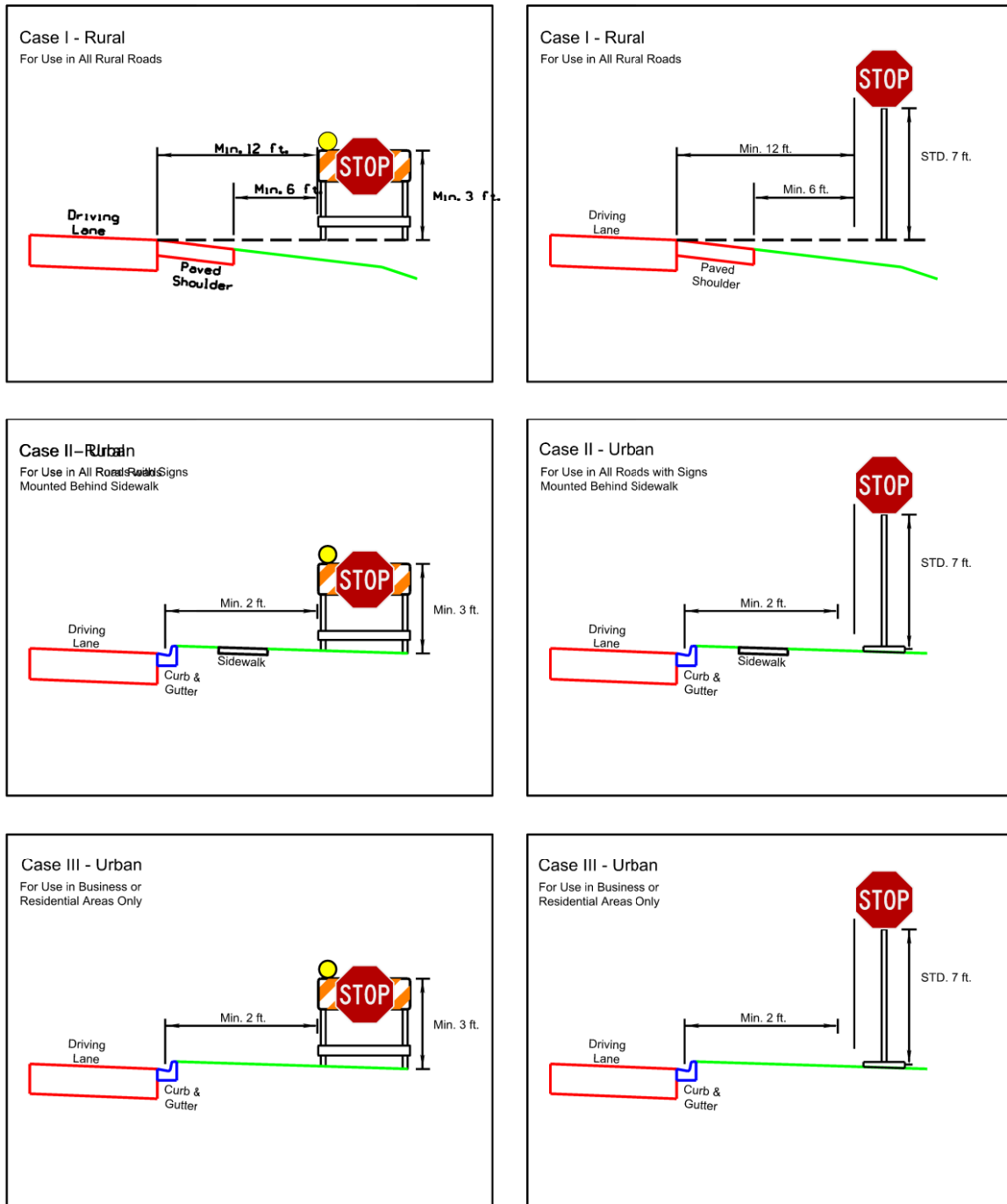

The above sign offset distances and height measurements are from the [MUTCD](#). During a Governor's emergency declaration, these distances may vary at the discretion of the [DTE](#).

## Section 2.39

### WARNING, STOP, AND YIELD SIGN SIZES

#### 2.39.1 BACKGROUND

- (1) Drivers (65 years and older) experience visual decline and slower reaction time and reduced visual acuity is associated with crash rates. Warning, STOP, and YIELD signs are critical to the safe operation of motor vehicles by all drivers. In order to determine the appropriate sizes that should be used for these critical signs, the [State Traffic Engineering and Operations Office](#) conducted a study.
- (2) The minimum required corrected visual acuity to obtain a driver's license in the State of Florida is 20/70. Therefore, this value was selected as the design visual acuity goal for these critical signs. Based on this design goal, the required sizes of Warning, STOP, and YIELD signs were determined and are presented in this section.
- (3) The minimum sign sizes referenced in this section shall be used on all future projects and as replacements when necessary due to sign damage or expiration of useful sign life.

#### 2.39.2 RECOMMENDED WARNING SIGN SIZES

- (1) The recommended symbol warning sign sizes in **Table 2.39-1, Recommended Symbol Warning Sign Sizes** meet the design goal for 20/70 visual acuity.

**Table 2.39-1. Recommended Symbol Warning Sign Sizes**

SIGN CODE	SIGN SIZE (Inches)	SIGN SYMBOL
W3-1	36	Stop Ahead
W3-2	36	Yield Ahead
W3-3	36	Signal Ahead
W3-5	36	Speed Reduction
W11-10	36	Truck Crossing

- (2) The recommended word message warning sign sizes in **Table 2.39-2, Recommended Word Message Warning Sign Sizes** meet either the minimum design goal of 20/70 visual acuity or the most acuity available by using a 48-inch diamond shape sign.

**Table 2.39-2. Recommended Word Message Warning Sign Sizes**

SIGN CODE	SIGN SIZE (Inches)	LETTER SERIES	PRIMARY LETTER HEIGHT (Inches)	MINIMUM REQUIRED ACUITY 20/x	SIGN MESSAGE
W5-1	48	D	8	64	Road Narrows
W5-2	48	D	8	64	Narrow Bridge
W5-3	48	C	8	54	One Lane Bridge
W8-1	36	D	10	80	Bump
W8-2	36	E	10	88	Dip
W8-3	48	C	8	54	Pavement Ends
W8-4	48	C	8	54	Soft Shoulder
W8-6	48	C	8	54	Truck Crossing
W8-7	48	D	8	64	Loose Gravel
W8-8	48	D	8	64	Rough Road
W8-9	48	C	8	54	Low Shoulder
W9-1	48	D	8	64	Right Lane Ends
W9-2	48	D	8	64	Lane Ends Merge Left
W13-1	24	E	10	88	35 MPH
W13-2	36 x 48	E	12	106	Exit 25 MPH
W13-3	36 x 48	E	12	106	Ramp 30 MPH
W14-1	48	D	9	72	Dead End

- (3) A No Passing Zone sign (**W14-3**) shall be 36 x 48 inches with 5-inch Series D lettering on the words NO and PASSING and 5-inch Series C lettering on the word ZONE.
- (4) Right-of-way constraints may sometimes limit the size of warning signs. When this occurs, the largest sign that will fit shall be used.
- (5) For any sign that isn't designed for 20/70 visual acuity there will be less legibility distance and therefore less time to perceive and understand the message before passing the sign. However, by adding the following additional distances to the sign placement distances shown in [Table 2C-4. Guidelines for Advance Placement of Warning Signs](#) and referenced in [Section 2C.05 of the MUTCD](#), the same total distance from the point where the sign is just legible to the condition must be maintained. Add 25 feet for 8-inch Series C and 8-inch Series D letters; 50 feet for 5-inch Series D, 6-inch Series C, and 6-inch Series D letters; and 75 feet for 5-inch Series C letters.

### 2.39.3 RECOMMENDED STOP SIGN SIZES

- (1) The 48-inch STOP sign provides a minimum required acuity of 20/45. In addition, use of the larger STOP signs, in areas with restricted right-of-way, may present problems. Installation of the STOP AHEAD symbol warning sign will alleviate both of these problems.
- (2) **Table 2.39-3, Stop and Stop Ahead Sign Sizes and Placement** was produced to determine the required size for the STOP and STOP AHEAD sign, and the sign placement distance for the STOP AHEAD sign.

**Table 2.39-3. Stop and Stop Ahead Sign Sizes and Placement**

POSTED SPEED (mph)	STOPPING SIGHT DISTANCE (feet)	STOP SIGN SIZE <sup>1</sup> (inches)	STOP SIGN RECOGNITION DISTANCE (20/70) (feet)	STOP AHEAD SYMBOL SIGNS <sup>2</sup> (inches)	STOP AHEAD SIGN PLACEMENT DISTANCE (feet)
20	150	30	178	–	–
25	200	30	222	–	–
30	250	36	267	36*	125*
35	300	36	267	36*	175*
45	450	36	267	36	325
50	550	48	356	36	425
55	625	48	356	36	500

\*If needed for restricted sight distance locations in urban areas.

<sup>1</sup>On state highways, the 48-inch STOP sign should be considered for 45 mph or greater. STOP signs on roads intersecting the state highway are usually replaced in FDOT construction projects. The sizes in this section are recommended for the replacement signs. Motorists traveling on local roads, in urban areas, expect to encounter STOP signs. STOP signs larger than 36-inches should be used when greater emphasis or visibility is needed.

<sup>2</sup>On state highways, in rural areas, motorists may not expect to encounter a STOP sign. As an enhancement, the STOP AHEAD sign should be used for speeds equal to or greater than 45 mph. On local roads, in rural areas, motorists usually expect to stop as they cross a state highway. Where sight distance restrictions exist, a STOP AHEAD sign should be used.

- (3) The stopping sight distance shown in the table above were calculated using the equation on Page 113 of AASHTO's ***A Policy on Geometric Design for Highways and Streets (Green Book, 2004 edition)***, and is for level, wet pavement. The brake reaction time was increased from 2.5 to 3.5 seconds to accommodate drivers aged 65 years and older.

- (4) Both the stopping sight distance and the STOP AHEAD sign placement distance should be increased to compensate for longer stopping sight distance on downgrades.
- (5) The increase due to downgrades as steep as 6 percent does not change the results in **Table 2.39-3** for speeds up to and including 35 mph. **Table 2.39-4** gives the required additional distance due to downgrade. This increase should be added to both the stopping sight distance and the STOP AHEAD sign placement distance in **Table 2.39-3**.
- (6) The STOP AHEAD symbol sign should be placed according to Table 2.39-3, rather than [Table 2C-4. Guidelines for Advance Placement of Warning Signs](#), referenced in [Section 2C.05 of the MUTCD](#) for Condition B (Stop). The 36-inch size sign has 141 foot legibility for 20/70 visual acuity, which is greater than the required 125 feet.
- (7) If restricted right-of-way requires a STOP sign smaller than shown in this table, the largest possible size should be used and a 36-inch STOP AHEAD symbol sign should be placed according to **Table 2.39-3** and **Table 2.39-4**.
- (8) If restricted right-of-way demands a STOP AHEAD symbol sign smaller than 36-inch, the 30-inch sign will provide approximately 117 foot legibility. This sign should be placed 10 feet further from the STOP sign than the distance shown in **Table 2.39-3** and **Table 2.39-4**.

**Table 2.39-4. Additional Stopping Sight Distance and Stop Ahead Sign Placement Distance Due to Downgrade**

POSTED SPEED (mph)	ADDITIONAL DISTANCE (3% GRADE) (feet)	ADDITIONAL DISTANCE (6% GRADE) (feet)
45	25	50
50	50	75
55	50	100

- (9) When flashing beacons are used on the STOP sign, the STOP AHEAD sign is optional unless required because of restricted sight distance.

### 2.39.4 RECOMMENDED YIELD SIGN SIZES

The sizes for YIELD signs shall be as shown in [Table 2B-1 of the MUTCD](#) with a target compliance date of December 22, 2013.

## Section 2.40

### APPROVED SAFETY MESSAGES FOR PERMANENTLY MOUNTED DYNAMIC MESSAGE SIGNS

#### 2.40.1 PURPOSE

To provide a listing of approved standard safety messages that can be displayed on permanently mounted Dynamic Message Signs.

#### 2.40.2 DEFINITIONS

**Dynamic Message Sign (DMS).** Dynamic, changeable or variable message signs defined as programmable traffic control devices that display messages composed of letters, symbols/graphics or both. DMS are used to convey timely and important en route and roadside information to motorists and travelers about changing highway conditions to improve operations and reduce crashes. DMS may inform drivers to change travel speed, change lanes, divert to a different route, or to be aware of a change in current or future traffic conditions.

#### 2.40.3 APPROVED STANDARD SAFETY MESSAGES FOR DISPLAY ON PERMANENTLY MOUNTED DMS

Approved standard safety messages for display on a permanently mounted DMS can be found on the [Department's Highway Signing Program website](#).

## Section 2.41

### GUIDELINES FOR USE OF RETROREFLECTIVE STRIPS

#### 2.41.1 PURPOSE

To provide guidance on the use of retroreflective strips on sign posts when the material is required or a documented need exists to draw attention to the sign, especially at night-time. The objective of providing the retroreflective strips is to improve the conspicuity and presence of the signs.

#### 2.41.2 DEFINITIONS

**Conspicuity.** Easily seen or noticed; readily visible or observable.

#### 2.41.3 CONDITIONS FOR USE

- (1) Retroreflective strips should be used where a documented need exists to enhance sign visibility. The requirement for enhanced conspicuity as referenced in [Section 2A.15 of the MUTCD](#), for standard signs is generally based on the need to make a sign more visible. Retroreflective strips should only be used when there is a need for extra emphasis.
- (2) The following sign types require the use of retroreflective strips:
  - (a) WRONG WAY sign posts
  - (b) Crossbuck sign blades at all rail crossings and posts at all passive rail crossings
- (3) Use retroreflective strips on sign posts where a documented need exists or application has been proven to significantly reduce crashes for a given condition. The following sign types are appropriate based upon engineering judgement:
  - (a) Curve Warning Signs ([Section 2C.06 of the MUTCD](#))
  - (b) Do Not Enter Signs ([Section 2B.37 of the MUTCD](#))
  - (c) Stop, Yield or Other Regulatory Signs ([Section 2B.05 of the MUTCD](#))
- (4) For the more critical signs that happen to be placed in a less desirable location (in curves where headlamps don't align optimally, etc.), engineering evaluations may lead to a sign being upgraded with retroreflective strips. Engineering judgment includes considering high crash locations where the use of retroreflective strips on sign supports could improve sign visibility and provide

better guidance to motorists.

#### **2.41.4 SIGN DESIGN**

The specifications for retroreflective requirements are referenced in [\*\*\*Standard Specifications, Section 700.\*\*\*](#)

## Section 2.42

### EXPRESS LANES SIGNING

#### 2.42.1 PURPOSE

This section establishes a uniform basis for the design of express lanes signing.

#### 2.42.2 BACKGROUND

- (1) Express lanes design criteria are found in the [FDOT Design Manual \(FDM\)](#).
- (2) Express lanes signs shall comply with applicable provisions of [Section 2G of the MUTCD](#). Express lanes are referred to as Priced Managed Lanes in the MUTCD.

#### 2.42.3 CRITERIA

Express lanes signs include the following sign types:

- (1) Regulatory Signs
  - (a) Vehicle Eligibility Sign
  - (b) Express Lanes Termination Sign
  - (c) Toll Amount Sign
  - (d) Periods of Operation Sign (R3-44)
- (2) Advanced Guide Signs
  - (a) Point of Entry/Ingress signing
  - (b) Point of Exit/Egress signing

##### 2.42.3.1 Vehicle Eligibility Sign

The purpose of this sign is to convey the vehicle eligibility criteria established in [Rule 14-100.003, F.A.C.](#) regarding the number of axles and vehicle types permitted to use the express lanes. This sign shall be mounted overhead and over the lane to which it applies. An example of the Vehicle Eligibility Sign is shown in **Figure 2.42-1**.

Figure 2.42-1. Vehicle Eligibility Sign



### 2.42.3.2 Express Lanes Termination Sign

The purpose of this sign is to inform motorists that the express lanes are ending. This sign shall be mounted overhead and over the express lanes to which it applies. If space permits, three signs are preferred, at sequential spacing. Due to the large number of drivers over the age of 65 in Florida, increased letter height of 15 inches shall be used. Examples of the Express Lanes Termination Sign are shown in **Figure 2.42-2**.

Figure 2.42-2. Express Lane Termination Signs

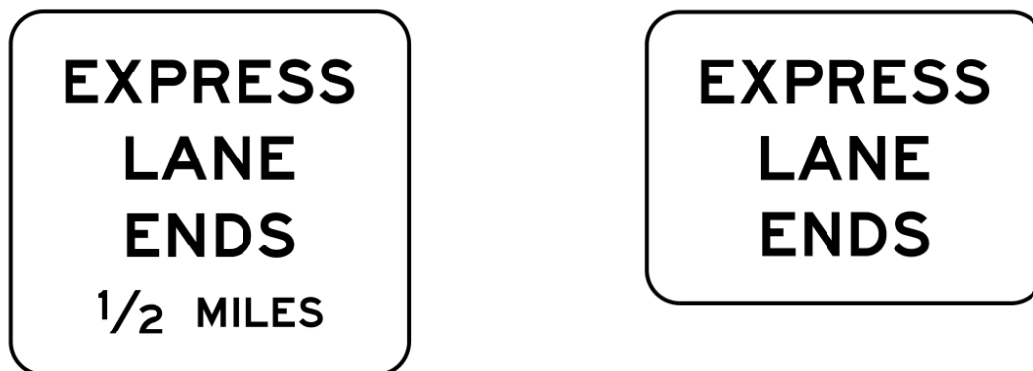

### 2.42.3.3 Toll Amount Sign (TAS)

- (1) As required by [Rule 14-100.003, F.A.C.](#), the TAS is used to display real-time toll amount information to users by identifying the cost of using the express lanes to a specific destination and the fee for toll violations. Since the TAS posts information that influences driver decisions to use the express lanes, it is important that the sign be clear, legible, and straightforward. Examples of the TAS are shown in **Figure 2.42-3**.

- (2) No more than three destinations shall be displayed on the TAS.
- (3) The toll violation message shall be black on white and displayed on the TAS.
- (4) The TAS shall be mounted overhead and over the lane to which it applies. See **TEM 2.42.4** for TAS sign placement and sequencing.
- (5) The TAS sign structures shall be designed to hold the maximum size panel of three destinations.
- (6) Destinations shall not be repeated on any TAS within the express lanes.
- (7) Two TASs, indicating the toll amounts for the next set of toll destinations, shall be installed (space permitting) over the express lanes prior to the last point of egress to the general use before beginning the new sequence of tolling trips.

**Figure 2.42-3. Toll Amount Sign**

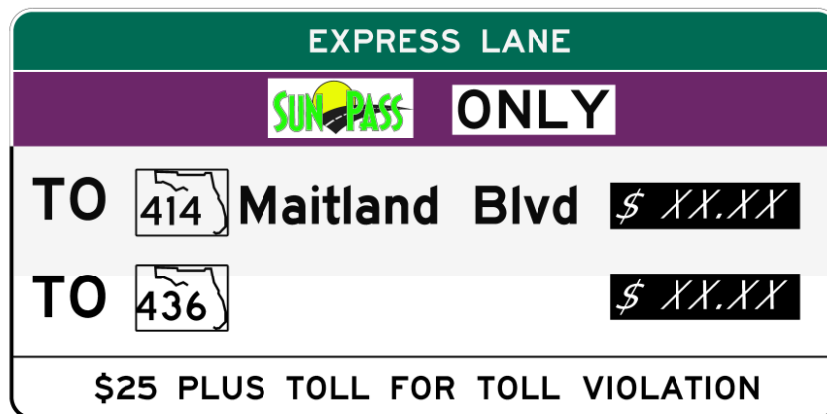

#### 2.42.3.4 Periods of Operation Sign (R3-44)

- (1) The purpose of this sign is to inform motorists of the beginning or entry point of an access-restricted express lane. This sign shall be installed at the beginning or entry point to the express lane in accordance with [Section 2G.17 of the MUTCD](#). An example of the R3-44 is shown in **Figure 2.42-4**.
- (2) The physical gore shall be used as the point of reference for the distance message on advance guide signs except when the physical gore and theoretical gore are separated by more than 500 feet. The theoretical gore shall be used as the point of reference when the physical gore and theoretical gore are separated by more than 500 feet.

**Figure 2.42-4. Periods of Operation Sign (R3-44)**



### **2.42.3.5 Advanced Guide Signs**

- (1) Per [Section 2G.10 of the MUTCD](#), if the Entry/Ingress or Exit/Egress is on the left side of the roadway, a LEFT plaque shall be added to the top left edge of the Advance Guide Signs. If the Entry/Ingress or Exit/Egress is a lane drop situation, the ONLY panel with down arrow shall be installed.
- (2) A “NO TRUCKS”, black on white, panel shall be added to the top of the advanced guide signs as shown in [Figure 2.42-5](#).
- (3) SunPass, or other interoperable transponders, is the only form of payment for the express lanes. The “SUNPASS ONLY” panel with purple background shall be included on the Advanced Guide Signs.

### **2.42.3.6 Point of Entry/Ingress Signs**

- (1) The access types for managed lanes are defined in the [EDM 211](#). The Point of Entry/Ingress Signs shall be installed at each access point. Examples of the Point of Entry/Ingress Signs are shown in [Figure 2.42-5](#).
- (2) When the point of entry is the initial entrance to the express lanes network, the advance overhead signing shall begin two miles prior to the express lanes entrance, space permitting. In addition to the initial entry/ingress express lanes signing, sequential overhead guide signs shall be located at one mile, ½ mile, and at the express lanes point of entry. For intermediate express lanes entry/ingress points the advance signing shall begin one mile prior to the express lanes ingress location and continue with the remaining sequence of signs.

Figure 2.42-5. Examples of Ingress Signing

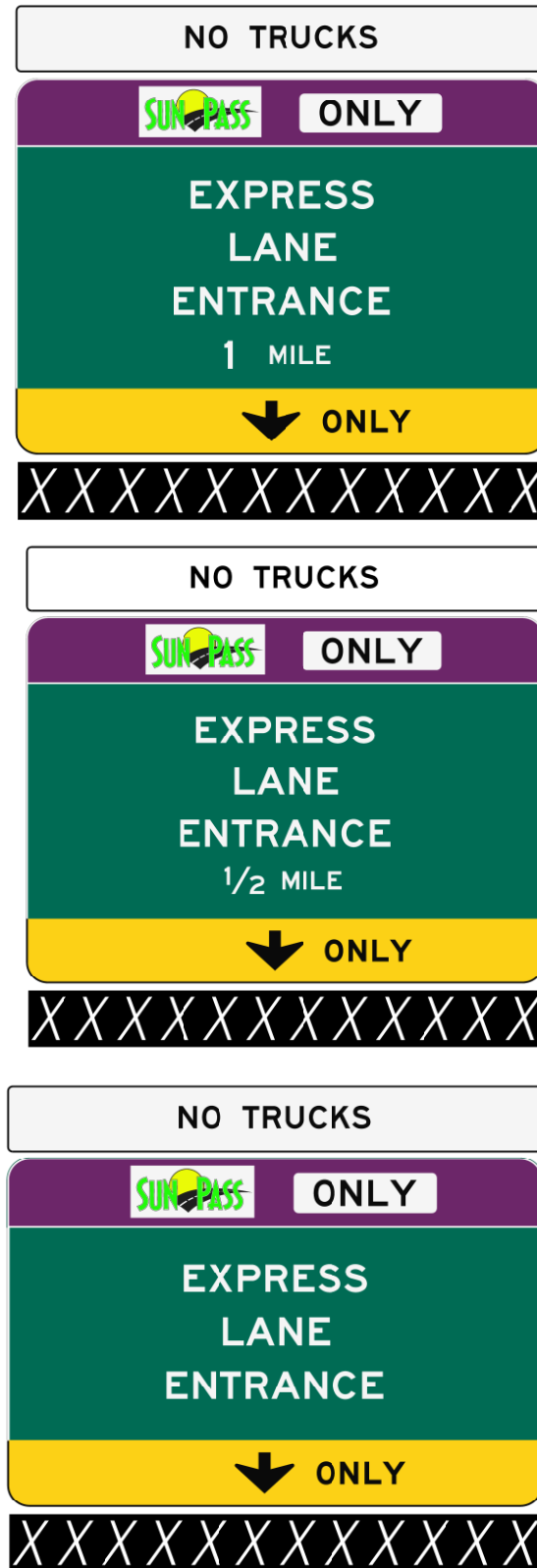

### 2.42.3.7 Point of Exit/Egress Signs

- (1) Intermediate point of exit/egress guide signs, or local exit signs, inform express lanes users which express lanes egress ramp serves their destination. Local exit signs shall be mounted overhead and over the lane to which it applies.
- (2) The destinations on the TASs shall be displayed the same way on the corresponding general use exit sign.
- (3) If three or more general use exits occur before the next opportunity to exit the express lanes, the egress signing should reflect this as shown in **Figure 2.42-6**.

Figure 2.42-6. Examples of Egress Signing

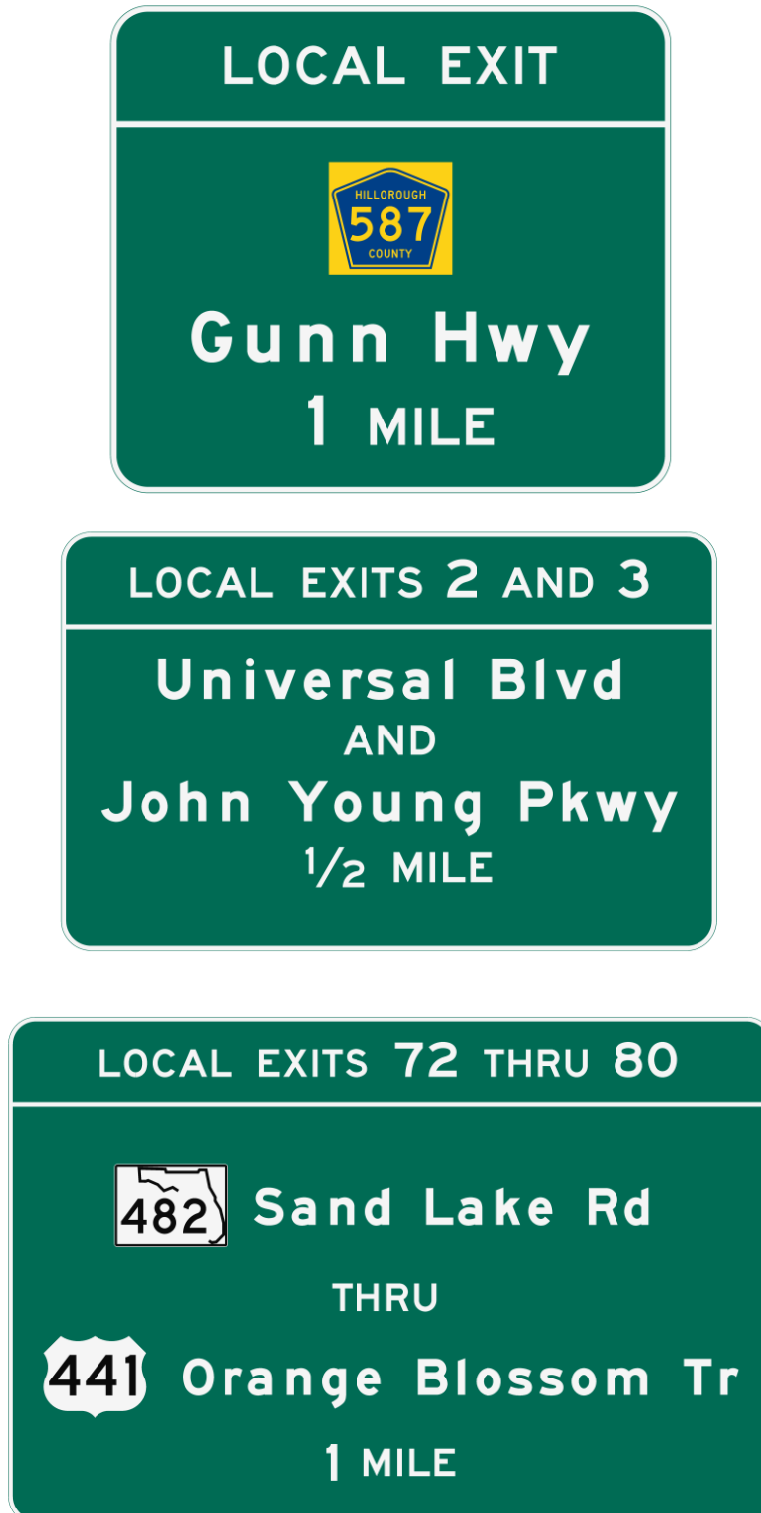



## Section 2.43

### RAMP ONLY SIGN PANEL

#### 2.43.1 PURPOSE

To establish a uniform basis for incorporating the 'RAMP ONLY' sign panel.

#### 2.43.2 BACKGROUND

[Section 2E.24 of the MUTCD](#) provides signing guidance for expressway and freeway lane drops at interchange exits. However, the [MUTCD](#) only provides limited guidance for signing a lane drop for a conventional road approach to interchanges onto a limited access facility. [Section 2D.45 of the MUTCD](#) states that “consistently applied signing for conventional road approaches to freeway or expressway interchanges is highly desirable.” The use of the 'RAMP ONLY' sign panel supports consistency for drivers on roadways with a through lane drop that carries an interchange entrance ramp.

#### 2.43.3 CONDITIONS FOR USE

- (1) The 'RAMP ONLY' sign panel ([Figure 2.43-1](#)) is used when it is important to inform motorists on low volume conventional crossroads that the through lane is being terminated (dropped) at the interchange entrance ramp. When used, this sign shall be mounted overhead and over the lane to which it applies.
- (2) The sign details for the 'RAMP ONLY' sign panel can be found in the [FHWA's Standard Highway Signs Manual 2012 Supplement](#) for the 'EXIT ONLY' (down arrow) (E11-1) sign. The number of arrows displayed on the sign panel shall correspond to the number of terminated lanes at the location of each sign. Placement of the down arrow shall comply with the provisions shown in [Section 2E.19 of the MUTCD](#).
- (3) The use of the 'RAMP ONLY' sign panel shall be coordinated with the [DTOE](#).

Figure 2.43-1. RAMP ONLY Sign Panel



## Section 2.44

### TURNING VEHICLES STOP FOR PEDESTRIANS SIGN

#### 2.44.1 PURPOSE

To provide guidance on the use of the TURNING VEHICLES STOP FOR PEDESTRIANS (*R10-15*) sign series on the State Highway System (SHS). Florida requires that the *R10-15a* sign be used on the SHS in accordance with [Section 316.130\(7\)\(a\) and \(b\), F.S.](#) These signs are used in support of [Section 316.130\(7\), F.S.](#), which requires a driver to stop before entering the crosswalk to allow the pedestrian to cross at a signalized intersection or a free-flow channelized turn lane. The objective of the *R10-15a* sign is to improve driver awareness to reduce pedestrian fatalities.

#### 2.44.2 GENERAL

The *R10-15* sign series should be used at signalized intersections that warrant additional emphasis to drivers turning at a signal where potential pedestrian conflicts might not be readily apparent. The [FHWA MUTCD letter of interpretation 2\(09\)-165\(I\)-R10-15 Modified with Stop Signal Symbol](#) allows the STOP sign symbol with the legend "FOR" (*R10-15a*) to be used in place of the YIELD sign symbol with legend "TO" on the *R10-15* sign.

#### 2.44.3 GUIDANCE

For signalized intersection or free-flow channelized right or left turn lane the *R10-15a* sign shall be used. Existing *R10-15* signs shall be replaced with the *R10-15a* signs during routine sign replacement activities. Sign details are available in the [Department's Sign Library](#).

Figure 2.44-1. R10-15a Sign



R10-15a for left-turn



R10-15a for right-turn

PROCEDURE



SIGNS



SIGNALS



MARKINGS



SPECIAL  
OPERATIONAL  
TOPICS



## Section 3.1

# SIGNALIZED INTERSECTION FLASHING MODE OPERATION AND FLASHING BEACONS

### 3.1.1 DEFINITIONS

**Flashing Beacon.** A Flashing Beacon is a highway traffic signal with one or more signal sections that operates in a flashing mode. It can provide traffic control when used as an intersection control beacon or as a warning beacon in alternative uses.

#### Flashing Operation of Traffic Control Signals.

- (1) **Non-Programmed Flashing Mode Operation.** The automatic transfer from a signalized intersection's normal mode operation (stop and go, steady red-yellow-green displays) to flashing mode operation (stop or caution, flashing red-yellow, or red indications) caused by a malfunction of the signal controller, a conflict in signal displays or manual selection of the flashing mode operation by maintenance or police personnel.
- (2) **Programmed Flashing Mode Operation.** The automatic transfer from a signalized intersection's normal mode operation (stop and go, steady red-yellow-green displays) to flashing mode operation (stop or caution, flashing red-yellow or red indications) during set times during the day.

### 3.1.2 RECOMMENDATIONS FOR SIGNALIZED INTERSECTIONS

#### 3.1.2.1 Programmed Flashing Mode Operation

Flashing operation is both energy and operationally efficient and is encouraged when consistent with the following recommendations:

- (1) Flashing yellow/red operation may be used when two-way traffic volumes on the main street are below 200 vehicles per hour.
- (2) Flashing yellow/red operation may be used during any hours of the day or night when [Warrant 1 and Warrant 2 of the MUTCD](#) are not met and where the two-way main street volume is greater than 200 vehicles per hour, provided the ratio of main street to side street volume is greater than 4:1.
- (3) Signal operation should be changed to regular operation if crash pattern or severity increases or there is an increase in conflicts.
- (4) A speedway effect can be avoided and uniform speeds obtained by maintaining sufficient signals cycling through steady red, green and yellow at proper spacing

so as to provide signal progression at an appropriate speed.

- (5) Traffic signals should be put on flashing operation primarily at simple traffic signal controlled intersections where the side street drivers have an unrestricted view of approaching main street traffic. Intersections with more than four legs, skewed intersections (greater than 15 degrees), or railroad preempted signals should not be considered for flash.
- (6) Flashing should be restricted to no more than 3 separate periods in a 24-hour period.

### 3.1.2.2 Non-Programmed Flashing Mode Operation

All signalized intersections shall automatically transfer to flashing mode immediately (no clearance interval) whenever a malfunction occurs during the normal mode operation of the signalized intersection.

### 3.1.3 APPLICATION REQUIREMENTS FOR SIGNALIZED INTERSECTION

The signal flashing mode and start-up sequence shall be as follows for:

#### 3.1.3.1 Yellow-Red Flashing Mode

- (1) **Main Street.** Flashing yellow during flashing mode, then steady green on start-up sequence.
- (2) **Protected Left Turns.** Flashing red during flashing mode, then steady red on start-up sequence. Protected left turn signals should carry all arrow indications.
- (3) **Side Street.** Flashing red during flashing mode, then steady red on start-up sequence.

#### 3.1.3.2 Red-Red Flashing Mode

- (1) **Main Street.** Flashing red during flashing mode, then steady green on start-up sequence.
- (2) **Protected Left Turns.** Flashing red during flashing mode, then steady red on start-up sequence. Protected left turn signals should contain all arrow indications.
- (3) **Side Street.** Flashing red during flashing mode, then steady red on start-up sequence.

### 3.1.4 HEADS TO BE FLASHED

[Section 4D.30 of the MUTCD](#) requires all signal faces on an approach to be flashed when the signal is in flashing mode operation. Therefore, a left or right turn signal not illuminated during flashing mode operation is unacceptable. [Section 4D.30 of the MUTCD](#) requires the flashing of red or yellow arrow indications.

Pedestrian signal indications (WALK and DON'T WALK) shall not be illuminated during flashing mode operation at signalized intersections.

### 3.1.5 FLASHING INDICATION COLORS

- (1) The color to be flashed, red or yellow circular indication, or arrow indications shall be determined as follows:
  - (a) Each approach or separately-controlled turn movement that is controlled during normal stop-and-go operation shall be provided with a flashing display.
  - (b) All signal faces on an approach shall flash the same color, either yellow or red circular or arrow. However, separate signal faces for separately-controlled turn movements may be flashed as described in [Section 4D.30 of the MUTCD](#). Flashing yellow indications for through traffic do not have to be shielded or positioned to prevent visual conflict for drivers in separately-controlled turn lanes; however, shielding for separate protected turn movements shall be in accordance with [Section 4D.22](#), [Section 4D.23](#), and [Section 4D.24 of the MUTCD](#).
  - (c) When a signal face consisting entirely of arrow indications is to be put on flashing operation, or when a signal face contains no circular indication of the color that is to be flashed, the appropriate red or yellow arrow indication shall be flashed.
  - (d) When a signal face includes both circular and arrow indications of the color that is to be flashed, only the circular indication of that color shall be flashed. A 5-section head cluster shall be flashed the same color as the approach through lanes. Only circular red or circular yellow indications shall be flashed in a flashing mode operation.
  - (e) No steady green indication or flashing yellow indication shall be terminated and immediately followed by a steady red or flashing red indication without the display of the steady yellow change indication; however, transition may be made directly from a steady green indication to a flashing yellow indication. This applies to both the circular and arrow indications. The transition from stop-and-go to flashing operation, when the transition is initiated by a signal conflict monitor or by a manual switch, may be made at any time.

- (2) **Main Street, Through Traffic.** From flashing yellow to steady green.
- (3) **Main Street, Separate Left Turn.** From flashing red to steady red.
- (4) **Side Street, Through Traffic.** From flashing red to steady red.
- (5) Green arrow indications which are continuously illuminated during normal operations should be continually illuminated during flashing mode operation.

### 3.1.6 APPLICATION REQUIREMENTS FOR FLASHING BEACONS

- (1) All existing flashing beacons are considered to meet the [MUTCD](#) requirements whether they are single or dual indicated.
- (2) However, all new or replacement intersection control beacon installations shall be designed and installed with dual indications. Wherever practical, the dual indications shall both be positioned laterally within each approach width to the intersection. For example, a four-way beacon assembly over each side of a divided four-lane highway does not meet this requirement. In no instance shall intersection control beacon indications on an approach be closer than 8 feet apart measured horizontally.

### 3.1.7 OPERATION OF FLASHING BEACONS

- (1) Intersection Control Beacons. Dual indications for intersection control beacons displaying horizontally aligned red indications shall be flashed simultaneously. Alternate flashing of dual horizontally aligned red indications is reserved for highway approaches to a railroad. Two vertically aligned red signal indications shall be flashed alternately. Refer to [Section 4L.02 of the MUTCD](#).
- (2) Warning Beacons. Warning beacons typically are installed at obstructions or to emphasize warning signs. These may be singular or dual indications and may be flashed alternately or simultaneously. Refer to [Section 4L.03 of the MUTCD](#).

## Section 3.2

### GUIDELINES FOR LEFT TURN TREATMENT

#### 3.2.1 PURPOSE

This guideline can be used to determine the selection of the following types of left turn treatments, as defined in [Section 4D.17 of the MUTCD](#):

- (1) Permissive Only Mode
- (2) Protected/Permissive Mode
- (3) Protected Only Mode
- (4) Split Phasing (each direction alternatively has both left turn green arrow and circular green)

#### Option:

- (1) A flashing YELLOW ARROW signal indication may be displayed to indicate a permissive left-turn movement in either a protected/permissive mode or a permissive only mode of operation.
- (2) It is not necessary that the left-turn mode for an approach always be the same throughout the day. Varying the left-turn mode on an approach among the permissive only and/or the protected/permissive and/or the protected only left-turn modes, during different periods of the day is acceptable.

#### 3.2.2 LEFT TURN SIGNAL PHASING

- (1) If the need for left turn phasing on an intersection approach has been firmly established, the following guidelines should be used to select the type of left turn phasing to provide. Sound traffic engineering judgment should be exercised in applying these guidelines.
- (2) A protected/permissive mode should be provided for all intersection approaches that require a left turn phase unless there is a compelling reason for using another type of left turn phasing. If the decision between providing protected/permissive or protected only mode is not obvious, the traffic engineer should initially operate the left turn phase as protected/permissive mode on a trial basis. If satisfactory operations result, the protected/permissive mode should be retained. If unsatisfactory operations result, the protected/permissive mode should be converted to protected only mode.

- (3) A protected only mode shall be provided for an intersection approach if any of the following conditions exist:
  - (a) Two or more left turn only lanes are provided.
  - (b) Geometric conditions and resulting sight distance necessitate protected only mode.
  - (c) The approach is the lead portion of a lead/lag intersection phasing sequence.
  - (d) The use of offset left turn lanes to the degree that the cone of vision requirements in [Section 4D.13 of the MUTCD](#) for the shared signal display cannot be met.
- (4) A protected only mode may be considered if any of the following conditions exist:
  - (a) Speed limit of opposing traffic is higher than 45 mph.
  - (b) Left turn traffic must cross three or more lanes of opposing through traffic.
  - (c) A protected/permmissive mode is currently in use and the number of left turn angle crashes caused by left turn drivers on this approach exceeds six per year.
  - (d) Unusual intersection geometrics exist that will make permmissive left turning particularly confusing or hazardous, such as restricted sight distance.
- (5) A permmissive/protected mode can be used effectively for some intersection approaches if the traffic engineer feels that the advantage to be gained in better progression, as demonstrated in a traffic signal analysis computer program, is worth the violation of driver expectancy. However, use of this type of left turn phasing should be limited and should be restricted to only the following situations which will not create a left-turn trap:
  - (a) T-intersections where opposing U-turns are prohibited.
  - (b) Four-way intersections where the opposing approach has prohibited left turns or protected left turn phasing.
  - (c) Four-way intersections where the left turn volumes from opposing approaches do not substantially differ throughout the various time periods of a normal day, so that overlap phasing is not beneficial or required.
- (6) Split phasing can be used effectively if any of the following conditions apply:
  - (a) Opposing approaches are offset to an extent that simultaneous left turns from opposing directions would be impossible or hazardous.

- (b) Left turn volumes are extremely heavy on opposing approaches and both are nearly equal to the adjacent through movement critical lane volume.
- (c) Left turn volume is extremely heavy on an approach that does not include a separate left turn lane.
- (d) Drivers are permitted to turn left from more than one lane, but drivers are also permitted to use the right-most left turn lane as a through lane.

### 3.2.3 LEFT TURN SIGNAL DISPLAYS

The following are the left turn signal displays as referenced in [Section 4D.17 of the MUTCD](#) to be used with the various types of left turn phasing.

- (1) **Protected/Permissive Mode.** A 5-section signal display centered over the lane line between the left turn lane and the left-most through lane should be used. The 5-section signal display could serve as one of the two required through traffic signal heads. No supplemental signing should be provided.
- (2) **Protected Only Mode with a single left turn lane.** A 3-section vertical signal head from top to bottom -- (or left to right in a horizontally-aligned face) left turn red arrow, left turn yellow arrow, left turn green arrow) should be centered over the left turn lane.
- (3) **Protected Only Mode with two or more left turn lanes.** At least two 3-section vertical signal heads (or left to right in a horizontally-aligned face) as described in the paragraph above should be used with one centered over each left turn lane.
- (4) **Split phasing.** A 5-section signal display centered over the lane line between the left turn lane and the left-most through lane should be used. The 5-section signal display could serve as one of the two required through traffic signal heads. No supplemental signing should be provided.

### 3.2.4 SIGNAL DISPLAY FOR EXCLUSIVE LEFT TURN LANE

A 3-section (red, yellow, and green) signal face shall not be placed over, and/or devoted to, an exclusive left turn lane, unless the signal phasing sequence provides a protected left turn movement during the cycle.

### 3.2.5 LEFT TURN PHASES FOR SEPARATED LEFT AND THRU LANES

- (1) Left turn lanes at signalized intersections that are separated from through lanes by raised or painted islands may be operated as protected only mode, as protected/permissive or permissive only mode. If protected/permissive mode is used, the 5-section signal display should be placed overhead on the lane line between the adjacent through lane and the island so as to be obvious that the

signal display is shared. In all cases, the cone of vision requirements in [Section 4D.13 of the MUTCD](#) shall be met. Below is an illustrative example using standard lane widths on a 4-lane divided highway. A corresponding table for maximum allowable island width (without shifting the signal head) for the indicated signal head distance from stop line is given.

**Figure 3.2-1. Signal Head/Left-Turn Treatment**

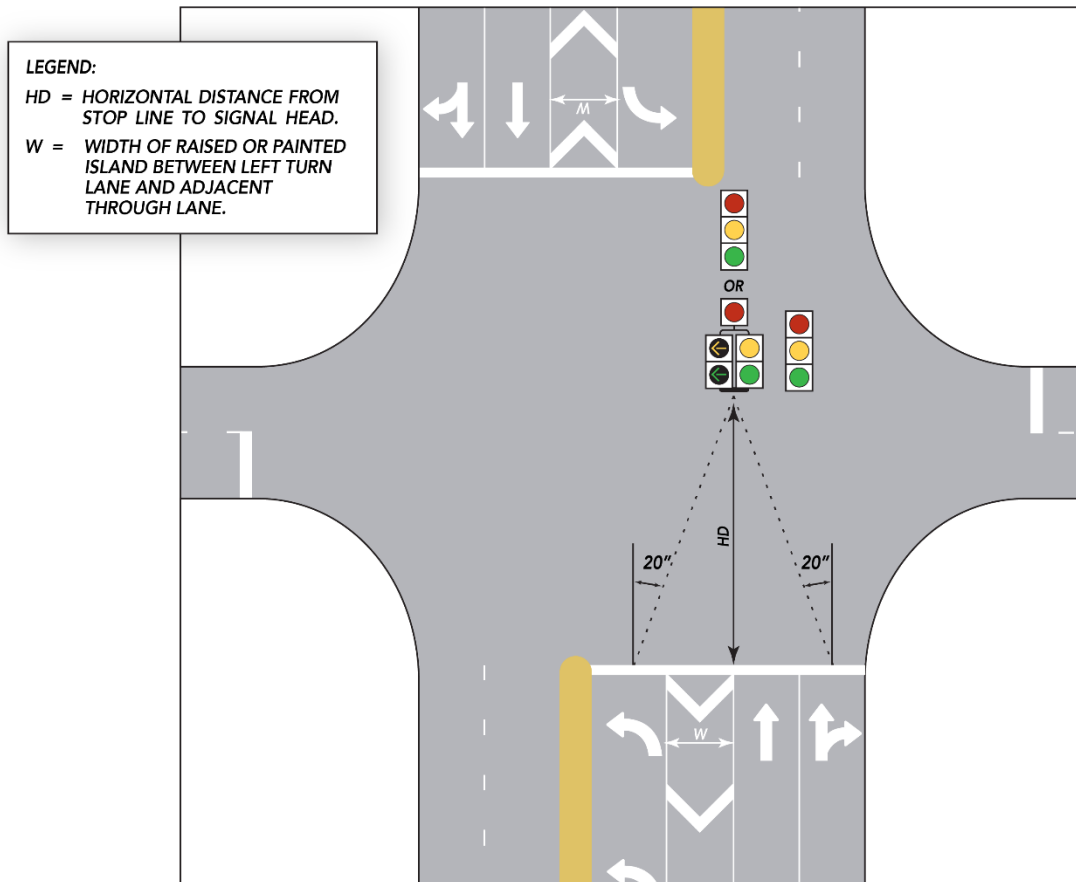
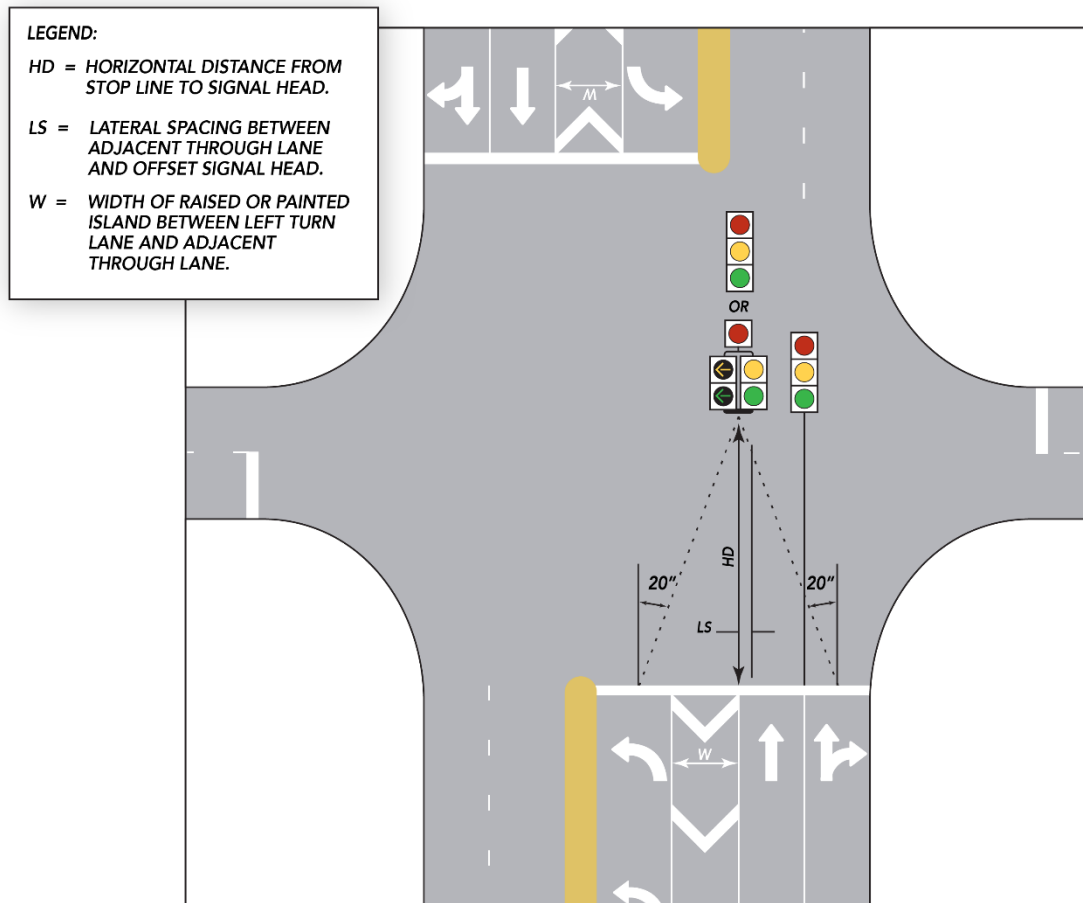

**Table 3.2-1. Maximum Width of Hatched-Out Area Without Shifting Signal Head**

Horizontal Distance	Width
40	8
50	12
60	15
70	19
80	23
90	26
100	30
110	34
120	37
130	41
140	44
150	48

- (2) Signal faces containing circular green signal indication for a permissive only left-turn should not be located above an exclusive left-turn lane or the extension of the lane, nor should they be post-mounted on the far side median in front of the left-turn lane. Permissive only left turn signal displays shall not be provided in an exclusive left turn signal face. If the separation or geometric conditions of the offset left turn lane is such that the cone of vision would not be met with a shared signal head positioned on the lane line adjacent to the nearest through lane, the shared signal face may be offset to the left from the adjacent through lane line such that the required cone of vision is still met for the right most through lane and for the left turn lane. This lateral offset spacing should be used only after other options such as increasing the horizontal distance to the signals heads has been considered and placed so as to be obvious that the signal display is shared. The lateral offset spacing of the shared signal head from the adjacent through lane generally should not be greater than one half the width of the island ( $\frac{1}{2}W$ ).
- (3) If the lateral shift is too great, the cone of vision may not be adequate for the driver in the right most through lane. Where the cone of vision cannot be met, protected only mode must be used. This may be due to a large parallel offset left turn lane or due to a tapered or curved offset left turn lane.

**Figure 3.2-2. Left Turn Lane Signal Head Shift**



### 3.2.6 PERMISSIVE ONLY MODE IN MULTI-LEFT TURN LANE APPROACHES

A permissive green interval for two or more left turn lane approaches shall not be used.

## Section 3.3

# SCHEDULING INTERSECTION CONTROL EVALUATIONS AND FUNDING ARRANGEMENTS

### 3.3.1 PURPOSE

To establish criteria for responding to requests for traffic signal installations, for funding and implementation arrangements for warranted signals, and for conducting related studies such as the Intersection Control Evaluation (ICE) to determine the need and type of improvement.

### 3.3.2 GENERAL

Since the Department is charged with the responsibility to erect and maintain a uniform system of traffic signals and other traffic control devices for regulation, control, guidance, and protection of traffic on the State Highway System, there is need to provide uniformity in responding to requests for signals and in the scheduling and conducting of traffic studies to determine signal needs. If an intersection is determined to meet signal warrants, the procedure as described in the [Department's Manual on Intersection Control Evaluation](#) must be conducted to determine the appropriate intersection control strategy.

### 3.3.3 RESPONSE TO SIGNAL REQUESTS AND SCHEDULING TRAFFIC SIGNAL STUDIES

- (1) The [District Traffic Operations Office](#) shall objectively review all requests for traffic signal installations received by the Department against existing information and local knowledge of the intersection before agreeing to commit resources for a detailed traffic study. This initial screening may require a brief site visit to view the field conditions. During the initial screening, all data shall be recorded in writing and kept on file. An attempt shall be made to relate all data and analysis to standards set forth in the [MUTCD](#). If the initial screening results in a decision to conduct a signal warrant study, the appropriate [District Traffic Operations Office](#) should contact the local government traffic engineering agency, advise them of the Department's decision, and obtain their views and input. Also, the appropriate [District Traffic Operations Office](#) should advise the local government traffic engineering agency that should signal warrants be met, an ICE analysis will be required to determine the appropriate intersection control strategy.
- (2) If the initial screening results in a decision to not consider signalization or further study, the [District Traffic Operations Office](#) shall document the reasons and advise the requestor of the findings with a copy to the local government traffic engineering agency. Although local government concurrence is desirable, it is not a prerequisite for committing Department resources to a full signal warrant study and subsequent ICE analysis if the signal is warranted.

- (3) The [District Traffic Operations Office](#) shall normally conduct signal warrant studies for proposed signal installations on the State Highway System. However, a local government traffic engineering agency may conduct such studies and submit them to the [District Traffic Operations Office](#) for review. All studies shall be conducted in accordance with the procedure and standards prescribed in this document and shall be signed and sealed by a professional engineer.
- (4) If the signal warrant study shows the installation of a new traffic signal is warranted, the [District Traffic Operations Office](#) or local government traffic engineering agency will conduct an ICE analysis to determine the appropriate intersection form.
- (5) Formal legal resolutions from local agencies may form the basis of their concurrence in the need for a traffic signal study. However, such documents should not be required by the Department as a prerequisite to scheduling the study. Additionally, the availability of implementation funds should not be a prerequisite to assessing traffic signalization needs (conducting a study).
- (6) The [District Traffic Operations Office](#) shall keep a log of requests for traffic signal studies and their disposition. To the extent practical, a priority system utilizing the request date, traffic volumes, accident experience, and the level of local government interest should be used to schedule traffic signal studies.

### 3.3.4 TRAFFIC SIGNAL STUDIES AND ENGINEERING

- (1) Department of Transportation staff, local agency engineers, or qualified consulting engineers may perform traffic signal studies, ICE analyses, and provide any required engineering services for the preparation of implementation plans and specifications for proposed traffic signals and/or alternative intersections on the State Highway System. However, the Department is responsible for requiring and overseeing such work.
- (2) Traffic signal studies shall be made in accordance with [Department's Manual on Uniform Traffic Studies \(MUTS\)](#), particularly, [Chapter 2 of the MUTS Manual](#), referred therein. ICE analyses shall be made in accordance with the [Department's Manual on Intersection Control Evaluation](#). Plans and specifications, if required, shall be prepared in accordance with established Department procedures.
- (3) Traffic signal studies, ICE analyses or engineering analyses conducted for new, or proposals to significantly revised, private access points to major traffic generators shall be conducted by qualified traffic engineers at no cost to the Department. Except under unusual circumstances, these studies and/or analyses shall be part of the Driveway Permit Application as per the requirements of [Rule 14-96](#). In accordance with [Section 2.3\(1\)\(d\) in the Department's Manual on Intersection Control Evaluation](#), a Driveway Permit Application for Category E, F, and G standard connection categories are required to conduct ICE analysis and have the analysis approved by both the District Design Engineer and the [District Traffic Operations Engineer \(DTOE\)](#). These studies shall, in addition to evaluating the need for signal control at unsignalized intersections and alternative intersections

forms from the ICE analyses, also consider enhanced features at existing upstream and downstream signalized intersections, as appropriate. Such study and report shall be signed and sealed by a Florida registered professional engineer. Likewise, engineering costs associated with the preparation of implementation plans and specifications should also normally be borne by the developer. There may be instances where the Department determines that specific critical design requirements make it essential that the engineering work be performed by Department forces. In such instances, the District Secretary may direct that the engineering work be done by the Department at no cost to the developer.

- (4) Studies and engineering at existing private access points which may be required as a result of normal traffic growth are usually made by qualified traffic engineers by the requestor. In extraordinary situations the Department may elect to do so.

### **3.3.5 FUNDING ARRANGEMENTS FOR WARRANTED NEW SIGNAL INSTALLATIONS**

- (1) New traffic signal installations and/or alternative intersections from the ICE analysis on the State Highway System may be funded from private, local, state, or federal funds, or any combination of such funds.
- (2) The developers shall totally fund the installation of any new traffic signal, any alternative intersection construction, and/or the enhancements of any existing traffic signals when these improvements are requirements specified in a new or revised Driveway Permit or local government Development Order. If proposals to provide signalization or alternative intersection or modify existing signalization is above the minimum required by Permit or Development Order and provides a betterment to the State Highway System substantially beyond mitigation for development impacts, the Department's District Secretary may determine an appropriate financial participation formula and assign percentages of participation to the developer in consideration of the specific conditions at each site.
- (3) Although signal installation and/or alternative intersection construction on the State Highway System is the responsibility of the Department, local governments may contribute, on a voluntary basis, a portion, or all of the cost of signal installation and/or alternative intersection construction depending upon specific cooperative arrangements worked out between the Department's District Offices and the local agency. Local funds are most often utilized in these cooperative efforts to advance the implementation schedule of a warranted traffic signal and/or alternative intersection. When local funds are accepted by the Department, a formal joint project agreement executed by both parties is necessary.
- (4) Most local governments in Florida's urban areas have qualified traffic engineering organizations with experienced traffic signal field crews and many new signals have been installed on the State Highway System using local agency installation crews with control hardware supplied by the Department. Where the local agency is agreeable to this procedure (most are because of their maintenance and

operational involvement in these sites), this technique should be encouraged. No formal agreement is necessary since no money is changing hands; however, a letter from the local agency agreeing to install Department supplied hardware should be obtained.

### 3.3.6 OTHER CONSIDERATIONS

- (1) Prior to purchase, use, or installation, traffic signals must comply with provisions of the [FDOT Approved Product List Submittal Process](#).
- (2) Prior to finalizing the agreement of intersection improvement, the study must comply with the [Department's Manual on Intersection Control Evaluation](#).
- (3) Prior to installation of traffic signals, compliance with [Topic No. 750-010-022, Traffic Signal Maintenance Agreements](#), is necessary.

## Section 3.4

### EMERGENCY TRAFFIC CONTROL SIGNALS

#### 3.4.1 PURPOSE

To provide guidance for warranting, designing, and operating emergency traffic control signals at locations where emergency vehicles, most commonly fire trucks, need special traffic signal assistance to egress onto the street system.

#### 3.4.2 BACKGROUND

The Department's district offices often receive local public agency requests for traffic signal control for the departure of emergency vehicles. This section was developed to give comprehensive guidance to determine if the signals are warranted.

#### 3.4.3 PROCEDURE

The need for an Emergency Traffic Control Signal shall be considered if an engineering study finds that one of the following warrants are met:

- (1) Minimum Traffic Volumes (Both directions of travel, based on Signal Warrant 2), as shown in **Table 3.4-1**.

**Table 3.4-1. Minimum Traffic Volumes**

Roadway	Peak Hour	or	24 Hours
2-Lane	750 VPH		7500 ADT
4-Lane	900* VPH		9000* ADT
6-Lane or more	1200* VPH		12000* ADT
*Values shall be increased by 1/3 when arterial has traffic signal system coordination with signals located within 1000 feet in both directions from the emergency signal location.			

- (2) When the geometric design of the arterial and emergency vehicle facility is such that the vehicle when returning must *back in*, and to do so must block traffic when performing this maneuver and the traffic volume and speeds are such that the use of emergency vehicle lights and flaggers have been ineffective in controlling traffic.
- (3) When the location of the emergency vehicle driveway consistently conflicts with the normal traffic queue from an adjacent signalized intersection. The use of DO NOT BLOCK INTERSECTION (**R10-7**) sign should be considered in conjunction with the emergency signal installation.

- (4) On all approaches when vertical or horizontal curvature or other obstructions do not provide adequate stopping sight distance for traffic approaching an emergency vehicle driveway.

### 3.4.4 CONFIGURATION AND OPERATION OF EMERGENCY TRAFFIC CONTROL SIGNALS

- (1) [Section 4G.03 of the MUTCD](#) defines the operational requirements for a *mid-block* location of an emergency signal. The MUTCD allows either a steady green or flashing yellow operation of signal heads between emergency vehicle actuations. These choices of operation, combined with limited details for signal configuration requirements have resulted in a lack of uniformity of emergency signal design and operation within the State.
- (2) Based on requirements contained in [Section 4G.04 of the MUTCD](#), the following criteria for emergency traffic control signals shall be followed for new or reconstructed installations.
  - (a) Dual indications shall be provided for each roadway approach. A minimum of one signal face shall be installed for the emergency vehicle driveway but two indications are preferable.
  - (b) If the emergency service is located off the main roadway and emergency vehicles access the main roadway via a public access street, emergency signals may be erected at the intersection of these roadways. If this practice is followed, dual indication shall be used on the public access street, with the signals resting on the flashing red indication.
  - (c) Mid-block emergency signals shall be operated as flashing yellow between emergency vehicle actuations. Roadway signal head configuration shall consist of three sections and shall be operated as shown in **Figure 3.4-1**. (The use of special technological signal devices may be selected, i.e., strobe signals, LED, or solar power. These devices may require temporary permitting prior to installation.)
  - (d) Signal operation at intersections which are pre-empted by emergency vehicles entering the roadway near or at the intersection should be designed on an individual basis.
- (3) It is not practical to outline all possible situations which may be encountered in the field. Such factors as emergency vehicle route distance between the intersection and emergency vehicle driveway, intersection geometrics, number of lanes, normal queue length, traffic volumes, etc., should be considered.

### **3.4.5 EMERGENCY SIGNAL SIGN (R10-13)**

- (1) As emergency signals are installed at locations along major arterials where emergency vehicles enter the roadway, the EMERGENCY SIGNAL sign (**R10-13**), shall be placed on the span wire or mast arm to identify the purpose of the signal to the driver.
- (2) The EMERGENCY SIGNAL sign (**R10-13**) shall always be legible, shall be mounted adjacent to each signal face, and shall be located between the dual signal indications on each roadway approach.
- (3) No sign is required for the emergency vehicle driveway approach.

### **3.4.6 OTHER REQUIREMENTS**

- (1) A controller timing chart shall be a part of the contract plans.
- (2) A Maintenance Agreement shall be required for all emergency signals on the State Highway System.
- (3) A signal timing study is required to determine proper clearance intervals.

Figure 3.4-1. Mid-Block Emergency Signal Operation

**(A) "EMERGENCY SIGNAL" SIGN**

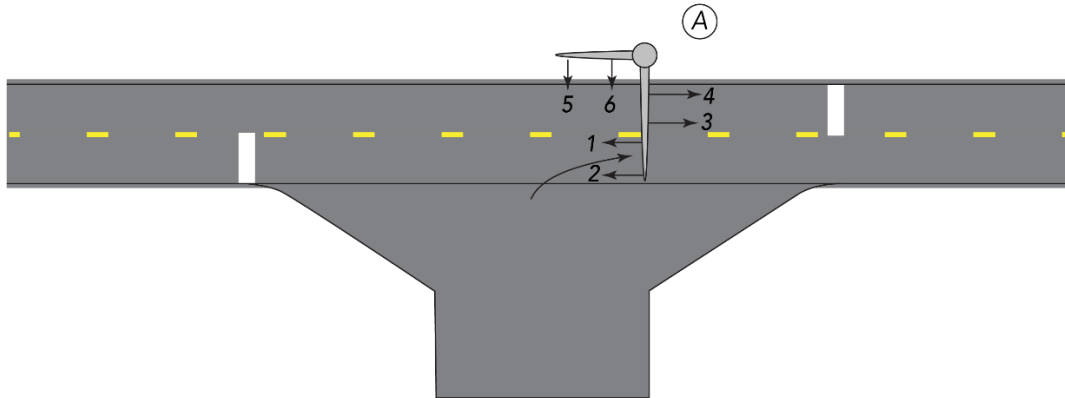

**NORMAL OPERATION**



**EMERGENCY PRE-EMPTION**



NORMAL OPERATION	CHANGE TO EMERGENCY PREEMPTION	EMERGENCY PREEMPTION	CHANGE FROM EMERGENCY PREEMPTION	RELEASE
<p><u>Signal 1, 2, 3, 4</u></p>	<p><u>Signal 1, 2, 3, 4</u></p>	<p><u>Signal 1, 2, 3, 4</u></p>	<p><u>Signal 1, 2, 3, 4</u></p>	<p><u>Signal 1, 2, 3, 4</u></p>
<p><u>Signal 5, 6,</u></p>	<p><u>Signal 5, 6,</u></p>	<p><u>Signal 5, 6,</u></p>	<p><u>Signal 5, 6,</u></p>	<p><u>Signal 5, 6,</u></p>

## Section 3.5

### TRAFFIC SIGNAL MAST ARM SUPPORT BOUNDARIES

#### 3.5.1 GENERAL

The [Department's Plans Preparation Manual, Topic No. 625-000-007, Volume 1 – Chapter 7](#) requires that all traffic signals installed on the State Highway System that are within the Mast Arm Structures Boundary shall be supported by mastarms.

#### 3.5.2 IMPLEMENTATION

##### 3.5.2.1 Mast Arm Structures Boundary Maps

The mast arm structures boundary map follows an alignment of state roads that are parallel to an approximate ten miles distance to the coastline. Official mapping of this boundary is maintained on a Map Info-Base by the [State Traffic Engineering and Operations Office](#). Current district maps are provided at this location: <https://www.fdot.gov/traffic/trafficservices/pdfs/districts>.

## Section 3.6

# STANDARDIZATION OF YELLOW CHANGE AND RED CLEARANCE INTERVALS FOR SIGNALIZED INTERSECTIONS

### 3.6.1 PURPOSE

The purpose of the yellow change and red clearance intervals is to provide a safe transition between two conflicting traffic signal phases. The function of yellow change interval is to warn traffic of an impending change in the right-of-way assignment and the function of the red clearance interval is to provide additional time following the yellow change interval to clear the intersection before conflicting traffic is released. The [MUTCD](#) states that a yellow change interval should have a minimum duration of 3 seconds and a maximum duration of 6 seconds and a red clearance interval should have duration not exceeding 6 seconds. The intent of this section is to provide a standard for uniform application of yellow and red intervals. These standards must comply for all of the following signalized intersection timing changes on the State Highway System (SHS):

- (1) New signal installations
- (2) All Traffic Infraction Detectors installed
- (3) Signal phasing changes
- (4) Geometric changes affecting the timing or phasing
- (5) Corridor re-timing projects

All other existing signalized intersections on the State Highway System must be in compliance with standards implemented in this section as identified in [Traffic Engineering and Operations Bulletin 02-13, Standardization of Yellow Change Intervals for Signalized Intersections](#).

### 3.6.2 STANDARD

- (1) [Section 316.075\(3\)\(a\), F.S.](#) states that no traffic control signal device shall be used which does not exhibit a yellow or "caution" light between the green or "go" signal and the red or "stop" signal. The Statute is silent on the yellow clearance interval duration and does not mention nor mandates the use of a red clearance interval.

- (2) The formula in Institute of Transportation Engineers (ITE) publication ***Determining Vehicle Signal Change and Clearance Interval*** (1994) shall be used to calculate yellow change interval. For a given posted speed limit (PSL), if the ITE formula produces a value lower than that in **Table 3.6-1**, the yellow change intervals in **Table 3.6-1** shall be used. The yellow change intervals shall not be less than the standard values presented in **Table 3.6-1**. Yellow change intervals calculated to be lower than 3.4 seconds shall be set at no less than 3.4 seconds. The yellow interval shall not exceed 6 seconds. Any yellow change intervals that are greater than the standard yellow change intervals presented in **Table 3.6-1** of this section, for a given PSL, are allowed, but they shall be based on [Section 4D.26 of the MUTCD](#), engineering practice and the ITE formula.

The ITE's ***Guidelines for Determining Traffic Signal Change and Clearance Intervals*** (2020) includes an extended kinematic model for calculating the minimum yellow change interval and shall not be used in Florida. Refer to ITE's ***Determining Vehicle Signal Change and Clearance Interval*** (1994) for calculating the minimum yellow change interval.

- (3) Yellow change and red clearance interval times shall be rounded up to the nearest 0.1 second.
- (4) Approach speed used in **Table 3.6-1** and **Formula 3.6-1** is the PSL for the approach being analyzed.

### 3.6.2.1 Yellow Change Interval

- (1) The Florida yellow change intervals shown in **Table 3.6-1** are computed using **Formula 3.6-1** (found in ITE's ***Determining Vehicle Signal Change and Clearance Interval*** (1994)) with a PRT of 1.4 seconds and a grade of 0%. These intervals are the required standard minimum values.
- (2) A Perception Reaction Time (PRT) of 1.4 seconds shall be used.

**Table 3.6-1. Florida Yellow Change Interval (0.0% Grade) Standard\***

APPROACH SPEED (MPH)	YELLOW INTERVAL (SECONDS)
25	3.4
30	3.7
35	4.0
40	4.4
45	4.8
50	5.1
55	5.5
60	5.9
65	6.0
* For approach grades other than 0%, use ITE Formula.	

**Formula 3.6-1**

$$Y = t + \frac{1.47v}{2(a + Gg)}$$

Where:

- Y = Length of yellow interval, sec.
- t = Perception-reaction time (use 1.4 sec.)
- v = Speed of approaching vehicles, in mph.
- a = Deceleration rate in response to the onset of a yellow indication (use 10 ft/sec<sup>2</sup>)
- g = Acceleration due to gravity (use 32.2 ft/sec<sup>2</sup>)
- G = Grade, with uphill positive and downhill negative (percent grade/100)

**3.6.2.2 Red Clearance Interval**

A red clearance interval must be used. Providing adequate red clearance intervals can significantly impact intersection safety by reducing the probability of occurrence of right angle crashes, even if drivers run the red signal indication. The red clearance interval shall be determined using engineering practices. The values are typically computed using **Formula 3.6-2**, found in ITE's **Determining Vehicle Signal Change and Clearance Interval** (1994).

**Formula 3.6-2**

$$R = \frac{W + L}{1.47v}$$

Where:

R = Length of red interval, sec.

W = Width of the intersection, in feet, measured from the near-side stop line to the far edge of the conflicting traffic lane along the actual vehicle path.

L = Length of vehicle (Use 20 ft.)

v = Speed of approaching vehicles, in mph.

The minimum red clearance interval shall be 2.0 seconds and the maximum red clearance interval should normally not exceed 6.0 seconds. Red clearance intervals longer than the calculated values in **Formula 3.6-2** can be used at the engineer's discretion. This longer red clearance interval can be applied where the width of intersection, sight distance, complex intersections, crash history and any other unique conditions that may warrant longer red times are present. This interval extension shall meet the minimum/maximum guidance for red clearance interval. The determination shall be based on engineering judgment.

The [National Cooperative Highway Research Program \(NCHRP\) Report 731 Guidelines for Timing Yellow and All-Red Intervals at Signalized Intersections](#) recommends using a modified ITE formula that allows for 1.0 second reduction due to reaction time delay from the conflicting movement. Therefore, a 1.0 second reduction may be made in the values computed from **Formula 3.6-2** and applying engineering judgment. However, the red clearance interval shall be no less than 2.0 seconds.

## Section 3.7

### ACCESSIBLE PEDESTRIAN SIGNALS

#### 3.7.1 PURPOSE

To establish criteria for the installation and operation of accessible pedestrian signals on the State Highway System that provide information in non-visual formats, such as audible tones, speech messages, and/or vibrating surfaces.

#### 3.7.2 GENERAL

[Sections 4E.09 to 4E.13 of the MUTCD](#) establish the standards for accessible pedestrian signals installed on public roadways. [Section 4E.06 of the MUTCD](#) also contains guidance for accessible pedestrian signal installations. The [MUTCD](#) must be reviewed and considered with accessible signal installation requests.

#### 3.7.3 PROCEDURE

- (1) Accessible pedestrian signals installed on the State Highway System shall be reviewed and approved by the [DTOE](#) prior to installation.
- (2) Requests for accessible pedestrian signal installations received from the public, maintaining agencies, public agencies, or support groups for people with visual impairments will be reviewed by the [DTOE](#). The [DTOE](#) may request input from public agencies and organizations that support people with visual impairments to determine if accessible pedestrian signals would be effective and safe for users.
- (3) An engineering study shall be conducted if the initial [DTOE's](#) review supports the installation of the accessible pedestrian signal. The engineering study should consider the needs of all pedestrians and not just those with visual impairments.
- (4) The following features should be considered when reviewing requests for accessible pedestrian signals:
  - (a) potential demand for accessible pedestrian signals
  - (b) right on red movements
  - (c) free-flow right turn movements
  - (d) complexity of signal phasing

- (e) complexity of intersection geometry
- (f) traffic volumes during times when pedestrians might be present
- (g) audible tones or sounds that may cause confusion
- (h) verbal messages instead of tones or sounds
- (i) vibrotactile pedestrian devices
- (j) pushbutton or passive pedestrian detectors
- (k) sufficient automatic volume adjustment in response to ambient traffic sound level, 100dBA (decibels) maximum
- (l) locations with more than four lanes and/or greater than 35 MPH posted speed limit shall be given additional considerations for geometrics, operations, and pedestrian safety

### 3.7.4 APPROVAL/DENIAL PROCESS

- (1) The [DTOE](#) shall review all requests for accessible pedestrian signals received by the Department from an engineering study and/or local request before agreeing to approve the installation. The review should consider the needs of all pedestrians and not just those with visual impairments.
- (2) The initial review may require site visits to view the field conditions. During the initial screening, all data shall be recorded and maintained. An attempt shall be made to relate all data and analysis to standards set forth in [Sections 4E.09 to 4E.13 of the MUTCD](#).
- (3) If the initial review results in a decision not to install accessible pedestrian signals, the [DTOE](#) shall document the reasons and advise the requestor of the findings with a copy provided to the local government. Although local government concurrence is desirable, it is not a prerequisite for committing Department resources for an accessible pedestrian signal installation.

## Section 3.8

# RAILROAD TRAFFIC SIGNAL PREEMPTION TIME CALCULATION

### 3.8.1 PURPOSE

To provide guidance for determining the required preemption time for traffic signals adjacent to highway at grade rail crossings equipped with an active warning system.

### 3.8.2 BACKGROUND

This section is developed to give comprehensive guidance in determining traffic signal preemption time calculation as established in [Rule 14-57.013\(5\), F.A.C.](#)

### 3.8.3 GENERAL

- (1) When new and existing signalized intersections are within 200 feet of an existing or new grade crossing, a preemption phase shall be provided to the traffic control system. This must be designed in coordination with the active grade crossing traffic control device.
- (2) For new and existing traffic signal intersections between 200 and 500 feet of an existing or new grade crossing, an engineering study is required to determine if preemption is needed.
- (3) Preemption should be considered for new and existing traffic signal intersections greater than 500 feet of an existing or new grade crossing, when traffic is observed to queue past the grade crossing or there is potential for traffic to queue past the grade crossing.
- (4) Consulting and coordinating with the corresponding railroad agency, District Rail Office and the [DTOE](#) is required prior to implementation.

### 3.8.4 DEFINITIONS

**Advance Preemption (AP).** Notification of an approaching train is forwarded to the highway traffic signal controller unit or assembly by the railroad equipment in advance of the activation of the railroad warning devices. Advance preemption time (APT) is the duration for advance preemption.

**Clear Storage Distance (CSD).** The distance available for vehicle storage measured between 6 feet from the rail nearest the intersection to the intersection stop line or the normal stopping point on the highway.

**Controller's Equipment Response Time to Preempt (CERTP).** The time that elapses while the controller unit electronically registers the preempt call.

**Design Vehicle (DV).** The longest vehicle permitted by statute of the road authority (State or other) on that roadway.

**Design Vehicle Clearance Distance (DVCD).** The length, in feet, which the design vehicle must travel in order to enter and completely pass through the railroad crossing's Minimum Track Clearance Distance (MTCD). It is the sum of the minimum track clearance distance and the total design vehicle's length. Design vehicle length can be found on [FDOT Design Manual \(FDM\) 201](#).

**Design Vehicle Clearance Time (DVCT).** Time required for design vehicle to accelerate from a stop and travel through and clear of Minimum Track Clearance Distance (MTCD).

**Desired Minimum Separation Time (DMST).** A Time buffer between the departure of the last vehicle (the design vehicle) from the railroad crossing and the arrival of the train.

**Maximum Highway Traffic Signal Preemption Time (MHTSPT).** The maximum amount of time needed following initiation of the preemption sequence for the highway traffic signals to complete the timing of the right-of-way transfer time, queue clearance time, and separation time.

**Minimum Green Time during Right-of-way Transfer (MGTRT).** The minimum number of seconds that any existing phase will display a green indication before the controller unit terminates the phase through its yellow change and red clearance intervals and transition to the track clearance green interval. A MGTRT of 5 seconds is recommended for the transition to the track clearance green interval as rapid as possible.

**Minimum Track Clearance Distance (MTCD).** The length along the highway at one or more railroad tracks, measured from the portion of the railroad crossing automatic gate arm farthest from the near rail to 6 feet (2 m) beyond the tracks measured perpendicular to the far rail.

**Minimum Walk Time during Right-of-way Transfer (MWTRT).** The minimum pedestrian walk indication time. A MWTRT of 5 seconds is recommended for the transition to the track clearance green interval as rapid as possible.

**Other Green Time during Right-of-way Transfer (OGTRT).** Any additional green time preserved beyond the preempt minimum green time for the worst-case vehicle phase.

**Pedestrian clearance time during right-of-way transfer (PCTRT).** The pedestrian clearance (i.e., flashing don't walk indication) time for the worst-case pedestrian phase. A zero value is allowed for the most rapid transition to the track clearance green interval.

**Preempt Delay Time (PDT).** The amount of time, in seconds, that the traffic signal controller is programmed to wait from the initial receipt of a preempt call until the call is “verified” and considered a viable request for transfer into preemption mode.

**Preempt Trap.** A potential hazard condition that vehicles can continue to cross the tracks and possibly stop on the tracks when the gates do not block access to the crossing before the expiration of the track clearance green. For preempt trap, the track clearance green interval has already expired so there will be no further opportunity to clear.

**Preempt Verification and Response Time (PVRT).** The number of seconds between the receipt at the controller unit of a preempt call issued by the railroad’s grade crossing warning equipment and the time the controller software actually begins to respond to the preempt call.

**Queue Clearance Time (QCT).** The time required for the design vehicle of maximum length stopped just inside the minimum track clearance distance to start up and move through and clear the entire minimum track clearance distance.

**Queue Start-up Time (QST).** Time elapsed after beginning of track clearance green until design vehicle can start moving.

**Red Clearance Time (RCT).** The required red clearance interval time during right-of-way transfer prior to transition to track clearance.

**Required Preemption Time (RPT).** The time provided to the railroad signal designer.

**Right-of-way Transfer Time (RTT).** The maximum amount of time needed for the worst-case condition, prior to display of the track clearance green interval.

**Separation Time (ST).** The component of maximum highway traffic signal preemption time during which the minimum track clearance distance is clear of vehicular traffic prior to the arrival of rail traffic.

**Track Clearance Distance (TCD).** The length along a highway at one or more railroad tracks, measured from the highway stop line, warning device, or 12 feet perpendicular to the track center line, to 6 feet beyond the track(s) measured perpendicular to the far rail, along the center line or edge line of the highway, as appropriate, to obtain the longer distance.

**Track Clearance Time (TCT).** Time required to travel through the track clearance distance plus a four second separation time.

**Vehicle-gate Interaction.** When the automatic gate descends on a stationary or slow-moving vehicle as it moves through the minimum track clearance distance.

**Yellow Change Time (YCT).** The required yellow change interval time during right-of-way transfer prior to the track clearance.

### 3.8.5 PROCEDURE

The maximum preemption time for highway-rail grade crossings could be calculated with the following procedures.

(1) Calculate the Right-of-way Transfer Time (RTT).

The components of RTT include the preempt verification and response time, and the worst-case conflicting vehicle or pedestrian time. This will be done in the following steps:

**Step 1:** Calculate preempt verification and response time.

Collect the preempt delay time (seconds) and the controller response time to preempt (seconds). The preempt verification and response time (seconds) could be calculated by adding the preempt delay time and the controller response time together.

**Step 2:** Calculate the worst-case conflicting vehicle time.

Collect the minimum green time during right-of-way transfer (seconds), other green time during right-of-way transfer (seconds), yellow change time (seconds) and red clearance time (second). The worst-case conflicting vehicle time (seconds) is calculated by summing them up.

**Step 3:** Calculate the worst-case conflicting pedestrian time.

Collect the minimum walk time during right-of-way transfer, pedestrian clearance time during right-of-way transfer, vehicle yellow change time and vehicle red clearance time. The worst-case conflicting pedestrian time (seconds) is calculated by summing them up.

**Step 4:** Determine the worst-case conflicting vehicle or pedestrian time.

The worst-case conflicting vehicle or pedestrian time is the maximum of worst-case conflicting vehicle time from **Step 2** and worst-case conflicting pedestrian time from **Step 3**.

**Step 5:** Calculate the right-of-way transfer time.

The right-of-way transfer time is the sum of preempt verification and response time from **Step 1**, and the worst-case conflicting vehicle or pedestrian time from **Step 4**.

(2) Calculate the queue clearance time.

The queue clearance time includes the time that is required for the design vehicle to start moving, and the time for design vehicle to accelerate through the design vehicle clearance distance. This is calculated by the following six steps.

**Step 1:** Determine the queue start-up distance.

Measure the clear storage distance (CSD) and minimum track clearance distance (MTCD) for the highway-rail grade crossing. The queue start-up distance, L (feet), is calculated by adding the CSD with MTCD.

**Step 2:** Calculate the time required for design vehicle to start moving.

The time required for design vehicle to start moving, can be calculated, in seconds, as 2 plus the queue start-up distance, L divided by the speed of 20 feet per second.

**Step 3:** Determine the design vehicle clearance distance.

The design vehicle clearance distance is the sum of the minimum track clearance distance and the total design vehicle's length as shown in **Figure 3.8-1**.

**Figure 3.8-1. Geometric Data at the Highway-Rail Grade Crossing**

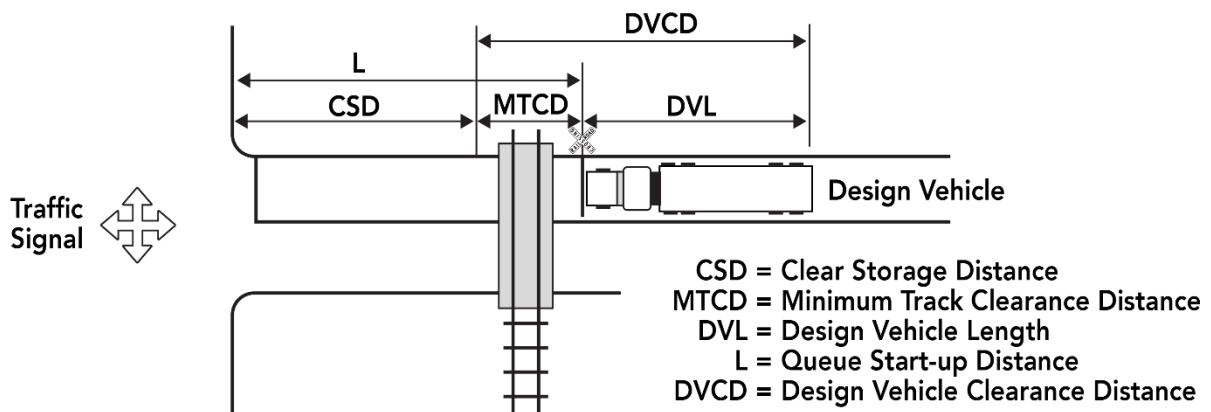

**Step 4:** Calculate the time for design vehicle to accelerate through the design vehicle clearance distance (DVCD) on level terrain.

Select the design vehicle for the analysis. Use **Figure 3.8-2** to determine the time for design vehicle to accelerate through the DVCD on level terrain.

**Figure 3.8-2. Acceleration Time Over a Fixed Distance on a Level Surface**

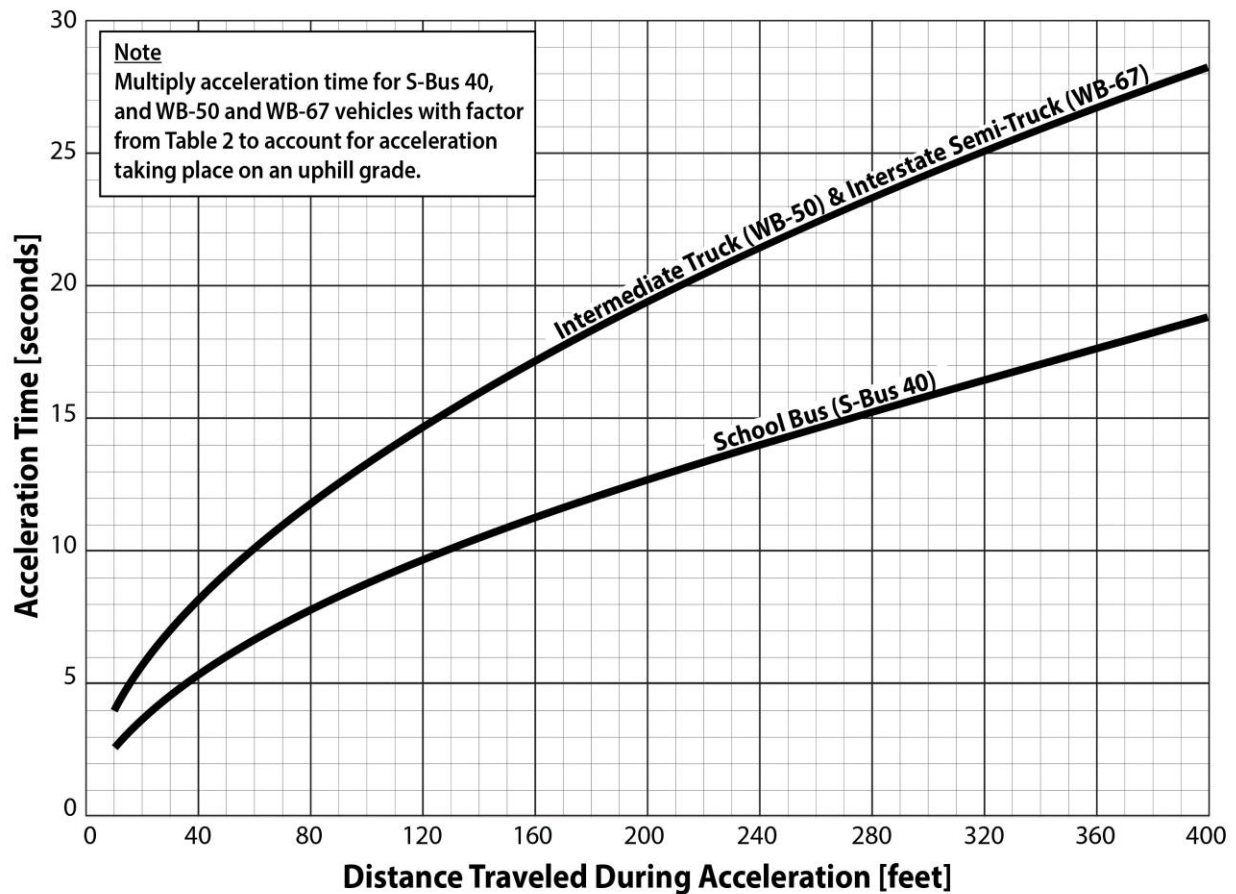

**Step 5:** Calculate the time for design vehicle to accelerate through the DVCD on uphill grade.

If the approach over which the design vehicle has to accelerate over DVCD is an uphill grade, calculate the approach grade factor to account for slower acceleration on uphill grade. The approach grade factor, as illustrated in **Table 3.8-1**, can be determined based on DVCD, design vehicle and the slope grade.

The time for design vehicle to accelerate through the DVCD on uphill grade can be calculated by multiplying the time for design vehicle to accelerate through the design vehicle clearance distance (DVCD) on level terrain with the approach grade factor.

**Table 3.8-1. Factors to Account for Slower Acceleration on Uphill Grades**

Acceleration Distance (ft)	Design Vehicle and Percentage Uphill Grade									
	School Bus (S-BUS 40)					Intermediate Truck (WB-50) and Interstate Semi-Truck (WB-67)				
	0-1%	2%	4%	6%	8%	0%	2%	4%	6%	8%
25	1.00	1.01	1.10	1.19	1.28	1.00	1.09	1.27	1.42	1.55
50	1.00	1.01	1.12	1.21	1.30	1.00	1.10	1.28	1.44	1.58
75	1.00	1.02	1.13	1.23	1.33	1.00	1.11	1.30	1.47	1.61
100	1.00	1.02	1.14	1.25	1.35	1.00	1.11	1.31	1.48	1.64
125	1.00	1.03	1.15	1.26	1.37	1.00	1.12	1.32	1.50	1.66
150	1.00	1.03	1.16	1.28	1.40	1.00	1.12	1.33	1.52	1.68
175	1.00	1.03	1.17	1.29	1.42	1.00	1.12	1.34	1.53	1.70
200	1.00	1.04	1.17	1.30	1.43	1.00	1.13	1.35	1.54	1.72
225	1.00	1.04	1.18	1.32	1.45	1.00	1.13	1.35	1.56	1.74
250	1.00	1.04	1.19	1.33	1.47	1.00	1.13	1.36	1.57	1.76
275	1.00	1.05	1.20	1.34	1.49	1.00	1.14	1.37	1.58	1.77
300	1.00	1.05	1.20	1.35	1.50	1.00	1.14	1.37	1.59	1.79
325	1.00	1.05	1.21	1.36	1.52	1.00	1.14	1.38	1.60	1.81
350	1.00	1.05	1.22	1.37	1.54	1.00	1.15	1.39	1.61	1.82
375	1.00	1.06	1.22	1.38	1.55	1.00	1.15	1.39	1.62	1.84
400	1.00	1.06	1.23	1.40	1.57	1.00	1.15	1.40	1.63	1.85

**Step 6:** Calculate the queue clearance time.

The queue clearance time is the sum of the time for the design vehicle to start moving and the time for design vehicle to accelerate through the design vehicle clearance distance.

**(3)** Select the desired minimum separation time (seconds).

The separation time is added for safety reasons and to avoid driver discomfort. The Institute of Transportation Engineers (ITE) recommends that the desired minimum separation time be four (4) seconds. This value may be reduced to as low as 0 seconds if the necessary warning time is not available.

**(4)** Calculate the maximum preemption time.

Sum the right-of-way transfer time, queue start-up time and desired minimum separation time for the required preemption time. If using Advance Preemption, check using worse-case scenario that the preemption phase does not end before the activation of the grade crossing warning devices. Variability in train arrival

times should be considered. Submit the calculated maximum preemption time to the [DTOE](#) and District Rail Office for approval.

- (5) Coordinate with the corresponding railroad agency and the railroad signal designer.

After approval by the [DTOE](#) and District Rail Office, provide the required preemption time to the railroad signal designer for them to determine the required rail warning system and timings.

### 3.8.6 PREEMPT TRAP CHECK

Variability in the actual warning time or insufficient track clearance green interval may result in the preempt trap when track clearance phase ends before the active railroad grade crossing warning lights start to flash or the gates start to descend. The preempt trap introduces the possibility that vehicles may cross or stop in the crossing after the end of the track clearance phase, without the opportunity to clear before the arrival of the train. The preempt trap can be checked with the following procedures.

- (1) Collect advance preemption time (APT).

Use the actual APT value provided by the railroad. If no APT is provided, a value of zero can be used.

- (2) Determine multiplier for maximum APT due to train handling.

The multiplier for maximum APT can be determined from field measurements as the largest APT observed divided by the APT.

If no field observations are available, the multiplier for maximum APT can be estimated as 1.60 if warning time variability is high (or 1.25 if warning time variability is low). High warning time variability can typically be expected in the vicinity of switching yards, branch lines, or anywhere low-speed switching maneuvers take place.

- (3) Calculate maximum APT.

The maximum APT can be calculated by multiple APT with the multiplier for maximum APT.

- (4) Calculate the minimum duration for the track clearance green interval.

The minimum duration for the track clearance green interval is calculated by subtracting the minimum time for flashing-light signal before the arrival of any train with the minimum time between the gate arm reaches its horizontal position and the arrival of the train.

- (5) Calculate the time for gates down after start of preemption.

Calculate the time by adding the maximum APT time to the minimum duration for the track clearance green interval.

- (6) Calculate the minimum right-of-way transfer time.

The minimum right-of-way transfer time is calculated by adding preempt verification and response time with best-case conflicting vehicle or pedestrian time. The best-case conflicting vehicle or pedestrian time is usually zero.

- (7) Calculate the minimum track clearance green interval.

The minimum track clearance green interval is calculated by subtracting the minimum right-of-way transfer time from the time for gates down after start of preemption. This is the minimum time that the track clearance green interval has to be active to avoid the preempt trap.

If the actual track clearance green interval is shorter than the minimum track clearance green interval, the preempt trap will occur.

### 3.8.7 VEHICLE-GATE INTERACTION CHECK

Even if sufficient warning time is provided and the preempt trap has been addressed, it's still possible that the automatic gates will descend on slow-moving or stationary vehicles (or vehicle-gate intersection), resulting in panic, confusion, or other unsafe actions. Long, high vehicles with low accelerations (such as tractor-trailers) are most exposed, especially to the gates "clipping" the rear of the trailer as the vehicle crosses the track during the clear track phase. **Figure 3.8-3** shows the relationship between descending gate and passing vehicle. The vehicle-gate interaction can be checked with the following procedures:

**Figure 3.8-3. Relationship between Descending Gate and Passing Vehicle**

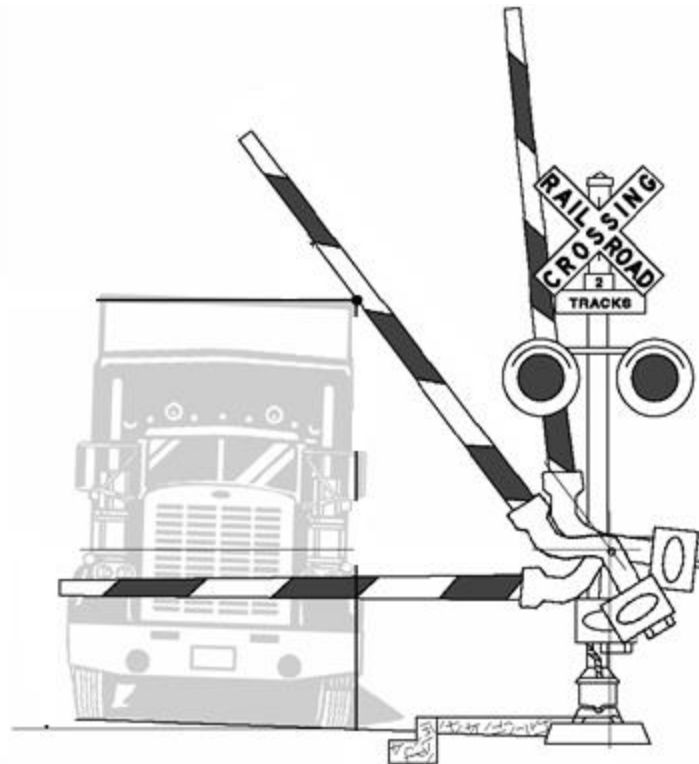

- (1) Calculate the time required for design vehicle to clear descending gate.

Collect the right-of-way transfer time and time required for design vehicle to start moving from previous steps. Calculate the time required for design vehicle to accelerate through DVL with **Figure 3.8-2** and **Table 3.8-1**.

The time required for design vehicle to clear descending gate is calculated by summing the right-of-way transfer time, time required for design vehicle to start moving, and the time required for design vehicle to accelerate through DVL up.

- (2) Collect duration of flashing lights before gate descent start.

This value typically ranges from 3 to 5 seconds and must be obtained from the railroad. The value obtained from the railroad may be verified using field observation.

- (3) Calculate non-interaction gate descent time.

**Step 1:** Collect the full gate descent time from railroad.

This value must be obtained from the railroad and may be verified using field observation. In the case where multiple gates descend at different speeds, use the descent time of the gate that reaches the horizontal position first.

**Step 2:** Determine the proportion of non-interaction gate descent time.

Determine the proportion of non-interaction gate descent time with **Figure 3.8-4**. Select the distance from the center of the gate mechanism to the nearest side of the design vehicle,  $d$ , on the vertical axis of **Figure 3.8-4**, draw a horizontal line until you reach the curve that represents the design vehicle ( $h$  is the vehicle height), and then draw a vertical line down to the horizontal axis and read off the value of the proportion of non-interaction gate descent time.

**Figure 3.8-4 Proportion of Gate Descent Time Available**

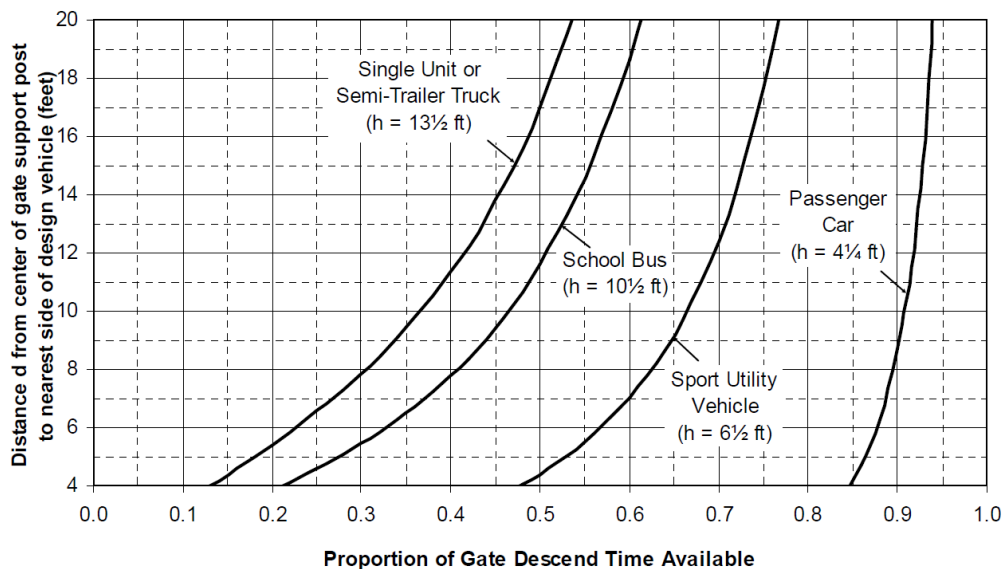

**Step 3:** Calculate the non-interaction gate descent time.

The non-interaction gate descent time is calculated by multiplying the full gate descent time with the proportion of non-interaction gate descent time.

(4) Calculate time available for design vehicle to clear descending gate.

The time available for design vehicle to clear descending gate is calculated by adding duration of flashing lights before gate descent start with non-interaction gate descent time.

(5) Vehicle-gate interaction check.

The vehicle-gate interaction can be checked by comparing the time required for design vehicle to clear descending gate with the time available for design vehicle to clear descending gate.

If the time available for design vehicle to clear descending gate is greater than or equal to the time required for design vehicle to clear descending gate, no vehicle-gate intersection will occur.

If the time available for design vehicle to clear descending gate is less than the time required for design vehicle to clear descending gate, APT time shall be provided to avoid design vehicle-gate interaction.

### 3.8.8 Example

The highway-rail grade crossing in **Figure 3.8-5** is within 200 feet of an existing signalized intersection. A preemption phase is required for the traffic control system. This example was developed to illustrate the step-by-step procedure for calculating the preemption time for highway-rail grade crossing.

**Figure 3.8-5 Intersection for Preemption Time Calculation**

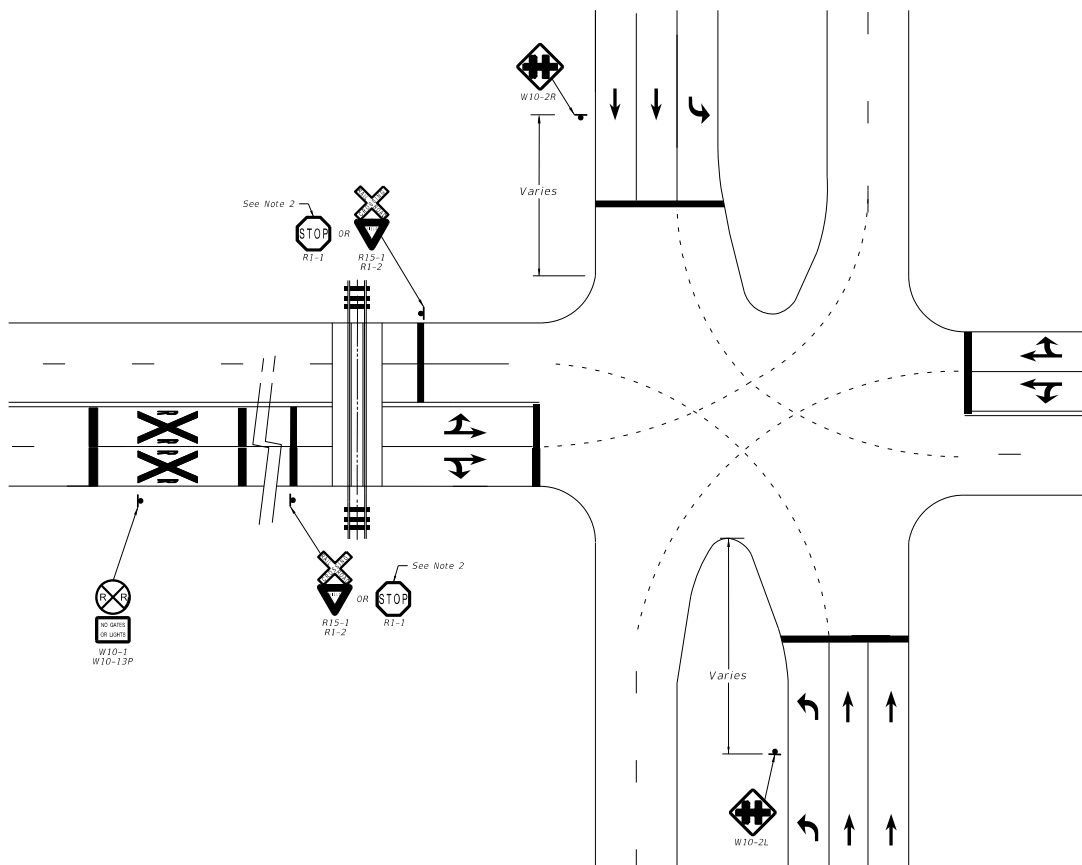

(1) Calculate the Right-of-way Transfer Time (RTT).

**Step 1:** Calculate the preempt verification and response time.

The preempt delay time is 0 seconds. The controller response time to preempt provided by the controller manufacturer is 0 seconds. The preempt verification and response time is 0 seconds by adding the preempt delay time and controller response time together.

**Step 2:** Calculate the worst-case conflicting vehicle time.

The worst-case conflicting vehicle phase number is 8 for this intersection. The minimum green time during right-of-way transfer is 5 seconds. The other green time during right-of-way transfer is 1 seconds. The yellow change time for Phase 8 is 4 seconds, and red clearance time for Phase 8 is 1 seconds. The worst-case conflicting vehicle time is 11 seconds.

**Step 3:** Calculate the worst-case conflicting pedestrian time.

The worst-case conflicting pedestrian phase number is 8. The minimum walk time during right-of-way transfer is 5 seconds. The pedestrian clearance time during right-of-way transfer is 0 seconds. The vehicle yellow change time is 4 seconds, and vehicle red clearance time is 1 second. The worst-case conflicting pedestrian time is 10 seconds.

**Step 4:** Determine the worst-case conflicting vehicle or pedestrian time.

The worst-case conflicting vehicle or pedestrian time is 11 seconds based on results from step 2 and step 3 above.

**Step 5:** Calculate the right-of-way transfer time.

The right-of-way transfer time is 11 seconds based on results from **Step 1** and **Step 4** above.

(2) Calculate the queue clearance time.

**Step 1:** Determine the queue start-up distance.

The measured clearance storage distance (CSD) is 54 feet. The measured minimum track clearance distance (MTCD) is 55 feet. The queue start-up distance is 109 feet.

**Step 2:** Calculate the time required for design vehicle to start moving.

The time required for design vehicle to start moving is calculated as below:

$$2 + 109 \div 20 = 8 \text{ seconds}$$

**Step 3:** Determine the design vehicle clearance distance (DVCD).

The minimum track clearance distance (MTCD) is 55 feet and the design vehicle length (DVL) is 48 feet. The design vehicle clearance distance is 103 feet based on MTCD and DVL.

**Step 4:** Calculate the time for design vehicle to accelerate through the DVCD on level terrain.

**Figure 3-8.6 Calculation of Time for Design Vehicle to Accelerate through the DVCD on Level Terrain**

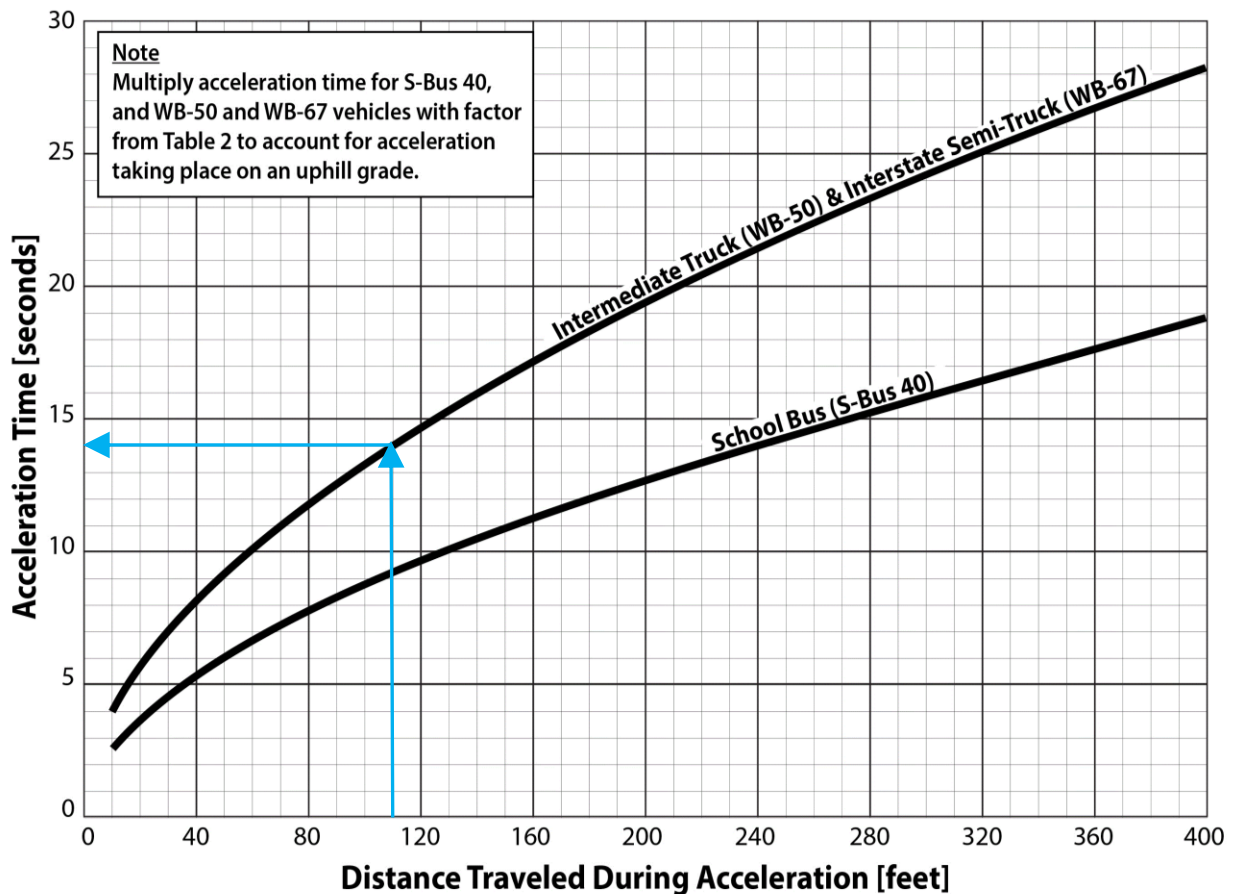

The design vehicle is WB 50 & WB-67. The time for design vehicle to accelerate through the DVCD on level terrain is 14 seconds based on **Figure 3.8-6**, as shown above.

**Step 5:** Calculate the time for design vehicle to accelerate through the DVCD on uphill grade.

The terrain for the selected intersection is level. Therefore, the calculation of time for design vehicle to accelerate through the DVCD on uphill grade is not needed.

**Step 6:** Calculate the queue clearance time.

The time required for design vehicle to start moving (**Step 2**) is 8 seconds, and the time for design vehicle to accelerate through the DVCD on level terrain (**Step 4**) is 14 seconds. The queue clearance time is 22 seconds based on results in **Step 2** and **Step 4** above.

(3) Select the desired minimum separation time.

The minimum separation time is 4 seconds based on the minimum recommended value found in the ITE Journal.

(4) Calculate the maximum preemption time.

The right-of-way transfer time is 11 seconds. The queue clearance time is 22 seconds. The desired minimum separation time is 4 seconds. The maximum preemption time is 37 seconds.

The final calculated maximum preemption time is 37 seconds for this intersection.

## Section 3.9

# INSTALLING RETROREFLECTIVE SIGNAL BACKPLATES ON EXISTING STRUCTURES

### 3.9.1 PURPOSE

To provide guidance on retrofitting existing signal structures with retroreflective signal backplates on the State Highway System.

### 3.9.2 BACKGROUND

- (1) The use of retroreflective signal backplates improves the contrast between the traffic signal indications and their surroundings for enhanced conspicuity during both day and night conditions and during power outages. The [FHWA Crash Modification Factor \(CMF\) Clearinghouse](#) reports a CMF for installing retroreflective signal backplates.
- (2) Rigid retroreflective backplates (RRBs) shall be installed on all new or reconstructed traffic signal structures for all approaches. However, retrofitting RRBs to existing signal head indications has been a challenge for many years due to the unknown structural capacity limits of existing signal support structures. Research and structural analysis evaluations using flexible retroreflective backplates have shown negligible wind loading impacts to mast arm and span wire support structures. The purpose of this section is to establish guidelines for installing flexible retroreflective backplates (FRBs) on existing mast arm and span wire structures at signalized intersections where backplates have not been utilized.

### 3.9.3 DEFINITIONS

**Flexible Retroreflective Backplate (FRB).** A signal backplate that allows portions of the panels to fold back when subjected to high winds and return to their original position when the wind subsides.

**Mast Arm.** A structure that is rigidly attached to a vertical pole and is used to provide overhead support of highway traffic signal faces or grade crossing signal units.

**Rigid Retroreflective Backplate (RRB).** A traditional signal backplate that remains fixed in one position when subjected to wind loading.

**Signal Face.** An assembly of one or more signal sections that is provided for controlling one or more traffic movements on a single approach.

**Signal Head.** An assembly of one or more signal faces that is provided for controlling

traffic movements on one or more approaches.

### 3.9.4 PROCEDURE

- (1) For existing mast arm and span wire structures, the use of FRBs that are listed on the [Department's Approved Product List \(APL\)](#) are exempt from the structural capacity analysis requirements of [FDM 261](#). This exemption is only applicable when the elements to be added to an existing signal structure are the FRBs. For all FRB installations, the [Districts Traffic Operations Offices](#) shall track and document locations and date of implementation by updating their respective **Traffic Signal Maintenance and Compensation Agreement (Exhibit A)** listings through the [Department's Transportation Data Portal \(GIS@FDOT\)](#).
- (2) All other signal hardware, features, and attachments that are proposed for retrofitting on existing traffic signal structures are required to undergo structural analysis in accordance with [FDM 261](#) to determine if adequate structural capacity is available. Examples of signal hardware, features and attachments requiring structural analysis include, but are not limited to:
  - (a) Rigid Backplates
  - (b) Signal Heads
  - (c) Overhead Street Name Signs
  - (d) Static Signs
  - (e) Blank out Signs
- (3) Structural analysis of existing traffic signal structures when required shall be performed in accordance with [FDM 261](#). Refer to the [Section 18.3, Volume 3 of the Structures Manual](#) for additional information regarding the analysis of existing structures. FRBs can be used to alleviate loading capacity per the [Structures Manual](#) guidance.

## Section 3.10

### FLASHING YELLOW ARROW SIGNAL APPLICATION

#### 3.10.1 PURPOSE

To establish criteria for the installation and operation of left and right turn flashing yellow arrow (FYA) signals. Also, to provide guidelines and best practices for installation of FYA signals at new and existing intersections consistent with [Section 4D.20 of the MUTCD](#).

#### 3.10.2 BACKGROUND

- (1) For many years, some engineers have had concerns that drivers turning left on a permissive circular green signal indication might inadvertently mistake that indication as implying the left turn has the right of way over opposing traffic, especially under some geometric conditions.
- (2) To date, research studies and guidelines have only been conducted for left turning FYA treatments. However, the use of right turn FYA treatments is permissible in accordance with the [MUTCD](#) and this section. Further guidance for right turn FYA treatments will be included upon research findings, implementation, and case studies.
- (3) In 2003, **National Cooperative Highway Research Program (NCHRP)** completed research for the "**Evaluation of Traffic Signal Displays for Protected/Permissive Left-Turn Control**" and published the [NCHRP Report 493](#). The key findings of the research are as follows:
  - (a) The FYA was found to be a good overall alternative to the circular green as the permissive signal display for a left-turn movement.
  - (b) The FYA was found to have a high level of understanding and correct response by left-turn drivers, and a lower fail-critical rate than the circular green.
  - (c) The FYA display in a separate signal face for the left-turn movement offers more versatility in field application. It is capable of being operated in any of the various modes of left-turn operation by time of day and is easily programmed to avoid the "yellow trap" associated with some permissive turns at the end of the circular green display.
- (4) The [FHWA Crash Modification Factor \(CMF\) Clearinghouse](#) reports a CMF for installation of left turn FYA signals and supplemental traffic signs.

### 3.10.3 OPERATIONAL REQUIREMENTS

In accordance with [Section 4D.20 of the MUTCD](#), the following design and operational requirements shall apply when a separate left-turn signal face is being operated in a protected/permissive left-turn (PPLT) mode and a flashing left-turn yellow arrow signal indication is provided.

**(1) Mode(s) of Left-Turn Operation:**

- (a) The flashing YELLOW ARROW signal indication may be displayed to indicate a permissive left-turn movement in either a protected/permissive mode or a permissive only mode of operation.
- (b) Varying the left-turn mode of operation from the permissive only and/or the protected/permissive and/or the protected only left-turns during different periods of the day is allowed when:
  - The Critical Gap is calculated to be 7 seconds at minimum during non-peak hours. The [Department's Manual on Uniform Traffic Studies \(MUTS\)](#) provides additional guidance on conducting vehicular critical gap studies.
  - The Left-turn volume routinely is less than 240 vehicles per hour on average or the product of opposing through and left-turn hourly volumes is less than 50,000 (one opposing through lane), or 100,000 (two opposing through lanes).
  - There are no fatalities and two or less left turn crashes per year that are attributed to permissive left turning movements.

**(2) Signal Face Arrangement:** At least one separate four-section signal face, in addition to the minimum of two signal faces for other traffic on the approach, shall be provided for the left-turn movement. The separate left-turn signal face shall be capable of displaying, from top to bottom (or left to right in a horizontally-aligned face), the following set of signal indications: Steady left-turn RED ARROW, steady left-turn YELLOW ARROW, flashing left-turn YELLOW ARROW, and steady left-turn GREEN ARROW.

**(3) Signal Face Location:** Within an exclusive left-turn lane that has a left-turn signal face mounted over the roadway, that left-turn signal face should be centered over the left-turn lane or the extension thereof. If centering of the overhead left-turn signal face is not practical, it shall not be positioned any further to the right than the lane line (or the extension of the lane line) between the left-turn lane and the adjacent through lane, nor shall it be positioned any further to the left than the left edge of the left-turn lane (or extension thereof).

- (4) **Signal Displays:** Signal head displays shall meet the following requirements:
- (a) Shall be capable of displaying the following signal indications: steady left-turn RED ARROW, steady left-turn YELLOW ARROW, flashing left-turn YELLOW ARROW, and left-turn GREEN ARROW. Only one of the four indications shall be displayed at any given time.
  - (b) During the protected left-turn movement, a left-turn GREEN ARROW signal indication shall be displayed.
  - (c) A steady left-turn YELLOW ARROW signal indication shall be displayed following the left-turn GREEN ARROW signal indication.
  - (d) During the permissive left-turn movement, a flashing left-turn YELLOW ARROW signal indication shall be displayed.
  - (e) A steady left-turn YELLOW ARROW signal indication shall be displayed following the flashing left-turn YELLOW ARROW signal indication if the permissive left-turn movement is being terminated and the separate left-turn signal face will subsequently display a steady left-turn RED ARROW indication. At locations where permissive left turn phases have shown to have a history of non-compliant driver yielding behavior to pedestrians and documented by the engineer, the following countermeasures may be implemented:
    - Omit FYA when the pedestrian phase is called.
    - Implement LPI in accordance with **TEM 3.11**.
  - (f) A flashing left-turn YELLOW ARROW signal indication shall be permitted to display for a permissive left-turn movement while the signal faces for the adjacent through movement display steady CIRCULAR RED signal indications and the opposing left-turn signal faces display left-turn GREEN ARROW signal indications for a protected left-turn movement.
  - (g) Before the FYA begins, provide a start-up delay (2 seconds) for all opposing through movements to establish position in the intersection.
  - (h) When changing phase from permissive left-turn movement to a protected left-turn movement, a left-turn GREEN ARROW signal indication shall be displayed immediately upon the termination of the flashing left-turn YELLOW ARROW signal indication. A steady left-turn YELLOW ARROW signal indication shall not be displayed between the display of the flashing left-turn YELLOW signal indication and the display of the steady left-turn GREEN ARROW signal indication. See **TEM 3.10.4** for further guidance.
  - (i) The display shall be a four-section signal face except that a three-section

signal face containing a dual-arrow signal section shall be permitted where signal head height limitations (or lateral positioning limitations for a horizontally-mounted signal face) will not permit the use of a four-section signal face. The dual-arrow signal section, where used, shall display a GREEN ARROW for the protected left-turn movement and a flashing YELLOW ARROW for the permissive left-turn movement. Prior to the use of three section signal face, where space limits a four-section signal face, concurrence and approval from the [DTE](#) will be required.

- (j) During steady mode (stop-and-go) operation, the signal section that displays the steady left-turn YELLOW ARROW signal indication during change intervals shall not be used to display the flashing left-turn YELLOW ARROW signal indication for permissive left turns.
  - (k) During flashing mode operation (see [Section 4D.30 of the MUTCD](#)), the display of a flashing left-turn YELLOW ARROW signal indication shall be only from the signal section that displays a steady left-turn YELLOW ARROW signal indication during steady mode (stop-and-go) operation.
- (5) **Yellow Trap:** FYA can be used to reduce the risk of a left turn yellow trap condition. Signal timing sequence may allow the permissive left-turn phase (FYA) to continue until the opposing traffic's through phase terminates, even if the adjacent through phase has already terminated. When implementing FYA engineers should review all potential sequencing combinations, including when phases are skipped due to lack of demand and special patterns such as preemption, to determine if a yellow trap situation could occur. If there is a possibility of a yellow trap, modifications to sequencing and controller programming parameters should be incorporated into design as necessary to eliminate the yellow trap. Primary responsibility lies with the design engineer to include adequate information in design plans for others who may be establishing sequences and controller programming.
- (6) The Four-Section Signal PPLT Mode ([Figure 3.10-1](#)), is illustrated in [Figure 4D-12 of the MUTCD](#).

**Figure 3.10-1. Four-Section Signal Protected-Permissive Left Turn Mode**

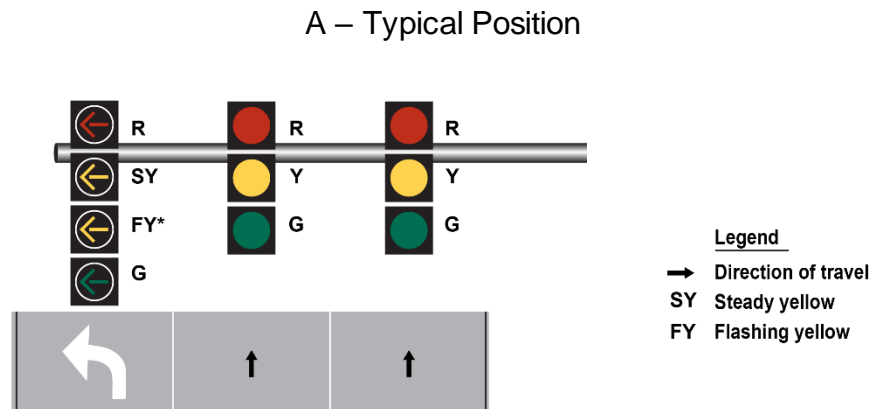

B – Typical Arrangements



### 3.10.4 INSTALLATION GUIDE

- (1) The FYA is an option for permissive/protected left turn phasing. However, as with protected/permissive operation in general, careful consideration is needed when deciding where to install the FYA.
- (2) Prior to implementing FYA at signalized intersections, it is recommended that the Districts obtain concurrence from the Local Agencies and provide them with information on where the FYA(s) are being proposed.
- (3) The following guidelines are provided to ensure statewide consistency during the installation of the FYA:
  - (a) Four-section FYA signal displays for new signal installations and candidate retrofit locations that meet the criteria below should be considered and prioritized based on the following:
    - Corridors where changing to lead/lag rather than lead/lead left-turn phasing would improve progression.
    - Locations where left-turn demand is low during off-peak periods and variable modes of left-turn phasing will improve safety and

operations.

- Locations where crash patterns involve left-turning vehicles and could be attributed to driver misunderstanding of shared signal indications.
  - Locations with frequent railroad or emergency vehicle preemption activations which result in higher risk of a left-turn trap condition.
  - Locations undergoing signal upgrades.
- (b) For new and retrofit FYA installation, the signal display for the left-turn movement should be centered over the corresponding exclusive left-turn lane.
- (c) For locations with a high 65 years and older population or intersections located in a [Safe Mobility for Life Coalition Priority County](#), careful and comprehensive intersection operations and crash history evaluation shall be conducted prior to implementation.
- (d) It is optional use of the supplemental LEFT TURN YIELD ON FLASHING YELLOW ARROW (**FTP-85-13**) sign during the initial implementation of FYA across the state to educate motorists on FYA operations.

The ability to install the supplemental LEFT TURN YIELD ON FLASHING YELLOW ARROW (**FTP-85-13**) sign depends on whether the structural loading capacity meets the minimum requirements to withstand the wind loading under the Department's established design criteria. Please see **TEM 3.10.4 (f)** for further guidance on loading.

- (e) FYA use for permissive-only, protected/permissive, permissive/prohibited phasing should consider time-of-day applications.
- (f) Phasing out the existing 5-section head by adding a separate 4-section FYA indication for the left-turn lane and 3-section indication for the inside through-lane. The Department will follow the [Traffic Engineering and Operations Bulletin 20-02. Adding Backplates to Existing Traffic Signals](#) to address reduced wind load requirements to facilitate the installation of the FYA signals in the most expedient manner.

### 3.10.5 INSTALLATION CRITERIA

- (1) Typically, isolated locations or sections of corridors with signalized intersections that have the following characteristics may be considered for installation of PPLT operation FYA:
- (a) Opposing left turn paths do not conflict.

- (b) Existing intersection geometry and traffic operations characteristics facilitate the installation of the FYA including:
    - Left turn crossing distance.
    - Available sight distance must be greater than required site distance based on approach speeds and left turn lane offset conditions.
    - Use when the approach has only one left turn bay.
    - Use when there are two opposing through lanes. Three opposing through lanes may be considered on a case-by-case basis.
  - (c) There is already an existing protective/permmissive operation in place and less than three left turn related collisions per year recorded over a three-year period susceptible to correction by protected-only phasing.
  - (d) Use the FYA when the left-turn volume is less than 240 vehicles per hour on average or the product of opposing through and left-turn hourly volumes is less than 50,000 (one opposing through lane), or 100,000 (two opposing through lanes).
  - (e) Signal coordination plans indicate operational improvement with the installation of FYA permmissive-protected operation based on volume criteria and crash pattern during peak periods.
- (2) While it is desirable to be consistent in the application of left turn treatment along a corridor for driver expectation, it may not be practical to install FYA left turn protected/permmissive mode in a consistent manner along a corridor. For example, FYA left turn operation requires a separate left turn signal face. Signalized intersections along a corridor equipped with shared signal faces that would require installation of new signal poles with longer mast-arms may be cost prohibitive to convert to FYA left turn operation.
- (3) There are existing implementations of FYA that have resulted in a mix of FYA and 5-section green ball protected/permmissive operation. However, it would be appropriate to install the FYA at a new signalized intersection meeting the criteria for PPLT mode operation on the corridor without immediately modifying the other existing intersections along the corridor. Preferably, the intersection should not be within view of other intersections with the 5-section green ball.
- (4) Consider using a FYA protected/permmissive mode at a location that previously operated in protected mode only after an engineering study of the intersection. Do not remove protected-only left turn phasing if opposing sight distance is inadequate for permmissive left turns, operating speed is too great, roadway geometry is complicated or there are too many opposing through lanes. For more information on sight distance refer to the [FDM 212](#).

### 3.10.6 VARIABLE MODE OF OPERATION

- (1) Variable mode operation, changing between protected only to protected/permissive mode, or between protected/permissive to permissive only operation by time of day is possible with the 4-section FYA signal face where an engineering study shows this type of operation will improve safety and operations. However, it is important to ensure that the traffic signal controller is capable of switching between modes in a manner such that the flashing yellow arrow indication and the opposing through movement indication terminate together.
- (2) When switching between protected/permissive to permissive only, ensure that the controller is capable of reassigning the left turn detectors to call the associated through phases by time of day.

### 3.10.7 PUBLIC NOTIFICATION

Installation of a FYA left turn operation should be coordinated with the District Public Information Office. Consider providing press releases with specific details on when the public can expect to see the new indications. Press releases should be prepared and sent out (approximately two weeks or more in advance of conversion).

### 3.10.8 EDUCATION

- (1) The Department's Safe Mobility for Life Program/Coalition developed a FYA tip card (**Figure 3.10-2**) to inform and educate the public about this new traffic control device. The tip card was developed using human factors studies to help the public simply understand what to do when encountering a FYA on the roadway system. This FYA tip card is part of the Roadway Safety Series and can be used by district staff for public outreach where these traffic control devices are installed. To obtain digital and/or print versions of the FYA educational materials, visit [SafeMobilityFL.com](http://SafeMobilityFL.com).
- (2) Location-specific education using Portable Changeable Message Signs (PCMS) should also be conducted. The following alternating messages should be displayed both prior to (minimum one week) and after implementation (maximum six weeks):
  - (a) Phase 1: NEW SIGNAL DISPLAY
  - (b) Phase 2: YIELD ON FLASHING ARROW

**Figure 3.10-2. Flashing Yellow Arrow Tip Card**

**What is a flashing yellow arrow?**

A new traffic signal that means you can turn left if there is a safe gap in traffic

SEE THIS	DO THIS
	Turn left.
	Prepare to stop or complete your left turn.
	Turn left provided there is a safe gap in vehicle and pedestrian traffic.
	Stop.

**What you need to know!**

**SafeMobilityFL.com**

### 3.10.9 SIGNAL RETROFIT CHECKLIST

Before FYA signal is set up in the field, the following checklist can be used to examine the existing hardware conditions at the intersections. Full awareness of the existing hardware conditions can facilitate a smooth implementation of FYA PPLT.

- (1) Check replacement head size/mounting. Sometimes, installation of four-section vertical signal head (to replace five-section doghouse) may need to raise wire spans.
- (2) Check if the number of available cables is sufficient to enable FYA signals. A common installation of PPLT phasing using a green ball for the permissive interval makes use of the green through phase to illuminate the green ball. Due to the flashing indication, additional cabling may be necessary in order for the flashing display to be controlled by its own circuit.
- (3) Check if the mast arm is long enough to center the FYA signal head over the exclusive left-turn lane.

- (4) Check status of signal equipment. Before implementing FYA signals, the equipment to be used should be checked, e.g., a malfunctioned load switch or a bad load switch socket may lead to problems during the implementation of FYA.
- (5) Confirm with signal equipment manufacturers about the applicability and programming method of the controller and management malfunction unit (MMU). Most leading signal equipment manufacturers have developed new models of controllers and MMUs that support FYA signal operations. Controllers must have the correct firmware to enable FYA operations.
- (6) Check if cabinet modification is required. Controller manufacturers have not standardized on FYA operation. Cabinet modification will depend on controller make and model. An MMU capable of FYA operation is required. Install a new MMU recommended by the controller manufacturer. A modification to the cabinet flash programming is required. Contact the manufacturer representative.
- (7) The [MUTCD](#) does not include a standard sign for FYA installation since it considers that FYA display is intuitively obvious in meaning to drivers and that an explanatory sign was unnecessary. However, the Department has designed a 36 x 30 inch white background and black lettering LEFT TURN YIELD ON FLASHING YELLOW ARROW ([FTP-85-13](#)) sign as shown in [Figure 3.10-3](#). The specific sign detail is shown in the [Standard Plans, Index 700-102](#) and can be installed adjacent to the new head for additional clarification. If the FYA face is to be installed at an existing location with a 5-section face, verify the sign can be installed and ensure any conflicting signs such as the LEFT TURN YIELD ON GREEN ([R10-12](#)) sign is removed if in place.

**Figure 3.10-3. Flashing Yellow Arrow Sign**

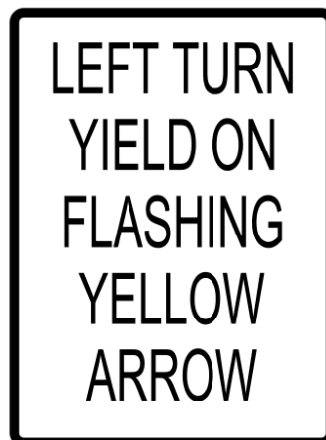

## Section 3.11

# SIGNAL TIMING APPLICATIONS FOR PEDESTRIAN MOVEMENT

### 3.11.1 PURPOSE

To define signal timing applications that can be used in traffic signals to improve safety and/or enhance mobility for pedestrian movements. For leading pedestrian interval (LPI) signal applications, criteria for implementation are provided for new and existing signalized intersections.

### 3.11.2 BACKGROUND

Many types of signal timing applications can be added to the traffic signals to improve traffic conspicuity and pedestrian safety. The [\*\*\*NCHRP Report 812 Signal Timing Manual\*\*\*](#) highlights some of the commonly used signal timing applications for pedestrian movement. Signal timing and signal timing adjustments shall be evaluated, determined, and documented by a Traffic Engineer.

This section defines some of those applications with additional guidance for LPI.

- (1) LPI is a low-cost countermeasure for pedestrian and vehicular traffic control at signalized intersections. LPI is also known as “pedestrian head start” or “delayed vehicle green” that gives pedestrians an advance “Walk” signal indication before a concurrent green signal is provided to vehicles. This will allow pedestrians to establish a presence in the crosswalk, thereby increasing the visibility of pedestrians to drivers and potentially reducing conflicts with turning vehicles.
- (2) LPI has been recommended as a countermeasure to reduce pedestrian-vehicle crashes at signalized intersections.

### 3.11.3 DEFINITIONS

**Automatic Pedestrian Recall.** A recall mode where there is a continuous call for pedestrian service, resulting in the pedestrian walk and clearance intervals timing every cycle. Automatic pedestrian recall eliminates the need for a pedestrian to push a pedestrian push button or passive detection of pedestrians and ensures that the pedestrian phase is presented each cycle.

**Pedestrian Scramble/Barnes’ Dance.** A separate phase that is configured such that no vehicular movements are served concurrently with pedestrian traffic where pedestrians may cross all intersection legs (and sometimes diagonally). Also known as Exclusive Pedestrian Phase.

**Flashing Don't Walk.** An indication warning pedestrians that the Walk indication has ended and the Don't Walk indication is underway.

**Lagging Pedestrian Interval.** A pedestrian interval option where the pedestrian walk interval starts several seconds after the adjacent through movement phase. This option allows a waiting right-turn queue to clear before the pedestrian walk indication is presented and reduces conflicts with right-turning vehicles. It is applicable to intersections where there is: (1) a high right-turn volume and (2) either an exclusive right-turn lane (or lanes) or the two intersecting roads have one-way traffic.

**Leading Pedestrian Interval (LPI).** A pedestrian interval option that starts a few seconds before the adjacent through vehicular phase, allowing pedestrians to establish a presence in the crosswalk, and thereby reducing conflicts with turning vehicles.

**Pedestrian Clearance Interval.** The time provided for a pedestrian to cross the entire width of an intersection. This interval is longer than the Flashing Don't Walk interval, as it can include the yellow change and red clearance intervals.

**Pedestrian Detector Call.** Enters a pedestrian demand for service into the associated phase of the controller unit.

**Pedestrian Omit.** Command which inhibits the selection of a phase resulting from a pedestrian call on the subject phase, and it prohibits the servicing of that pedestrian call. When active, the Pedestrian Omit prevents the starting of the pedestrian movement of the subject phase. After the beginning of the subject phase green, a pedestrian call is serviced or recycled only in the absence of a serviceable conflicting call and with Pedestrian Omit on the phase non-active. Activation of this input does not affect a pedestrian movement in the process of timing.

**Pedestrian Recycle.** Controls the recycling of the pedestrian movement. The operation depends on whether the phase is operating in the actuated or non-actuated mode:

- In the actuated mode, if a serviceable pedestrian call exists on the subject and the Hold input is active, the pedestrian movement is recycled when the Pedestrian Recycle input is active, regardless of whether a serviceable conflicting call exists.
- In the non-actuated mode, if the subject phase has reached the Green Dwell/Select state, the Pedestrian Omit is not active on the phase and a serviceable conflicting call does not exist, the pedestrian movement is recycled when the pedestrian recycle input is active.

**Pedestrian Walk Interval.** An indication providing initial right-of-way to pedestrians during a pedestrian phase and prior to the pedestrian clearance interval.

**Rest in Walk.** The pedestrian phase is set to rest in the walk interval to maximize the walk display during a vehicle green. This pertains whether the walk signal initially comes

on through activation of the pedestrian push button, passive pedestrian detection, or through automatic pedestrian recall. After a conflicting phase call is detected, the pedestrian change interval (flashing orange hand) begins timing.

**Walk Rest Modifier.** When activated, modifies non-actuated operation only. Upon activation, the non-actuated phase(s) remain in the timed-out WALK state (REST IN WALK) in the absence of a serviceable conflicting call without regard to the Hold input status. With the input nonactive, non-actuated phase(s) do not remain in the timed-out WALK state unless the Hold input is active. The controller unit recycles the pedestrian movement when reaching the Green Dwell/Select state in the absence of a serviceable conflicting call.

### 3.11.4 LPI IMPLEMENTATION

- (1) LPI signal applications shall comply with [Section 4E.06 of the MUTCD](#).
- (2) The engineer shall review all new signalized intersections and all signal timing changes for LPI implementation. LPI's may be implemented at the discretion of the [DTOE](#) in Context Classifications C2T, C4, C5, and C6, based on the assumption that these urban conditions will have higher volumes of pedestrian crossing movements and higher volumes of conflicting right turn traffic. For intersections in other context classifications, see **TEM 3.11.4(3)** for additional LPI criteria. The decision process for LPI implementation shall be documented in the project file in the format of either email or technical memorandum.
- (3) In Context Classifications C1, C2, C3R, and C3C, pedestrian crossing volumes cannot be assumed to be high enough in all cases to justify an LPI, and the engineer must conduct additional analysis to determine if an LPI is appropriate. The items in **TEM 3.11.4(3) (a)-(e)** may be considered as evidence for the need to implement an LPI. The engineer shall review and document in the project file the following conditions when reviewing LPI implementation:
  - (a) Crash history, near misses, and/or risk analysis indicating conflicts between turning vehicles on green and pedestrians.
  - (b) Determination of a visibility issue blocking drivers' view of pedestrians due to obstructions or poor sight distance. At a minimum, the following should be considered:
    - Sun angle that blocks visibility at certain times of day or times of the year
    - Lighting problems that cannot be adequately addressed through standard lighting requirements
    - Intersection geometry that tends to obscure pedestrians from motorists or vice versa

- (c) Citizen complaints about turning vehicles not yielding to pedestrians or observations of this type of behavior
  - (d) Intersection type is T-intersection or intersection with one-way road
  - (e) Where there is a strong pedestrian demand and/or there is high pedestrian movement, such as in proximity to shopping centers, transit facilities, or other pedestrian generators
  - (f) Multilane intersections where pedestrians may benefit from additional crossing time ahead of turning vehicles
- (4) LPI timing should allow pedestrians to clear the width of one lane in the direction of moving traffic, including the width of a parking and/or bicycle lane, to increase the visibility of pedestrians to turning traffic. A minimum of 3-second LPI duration is required by the [MUTCD](#). The **Formula 3.11.3-1** may be used to design LPI duration:

**Formula 3.11.3-1**

$$\text{LPI} = \text{ML}/\text{W}$$

Where:

LPI = Number of seconds (rounded up to the nearest second) between onset of “Walk” signal for pedestrians and green indication for vehicles

ML = Distance on crosswalk to clear width of one through lane from the edge of curb, in feet. (Should consider distance for large corner radius as per [Section 4E.06.22 of the MUTCD](#))

W = Walking speed (3.5 ft/s for pedestrian clearance calculation suggested by the [MUTCD](#), or 3.0 ft/s). The [Department’s Manual on Uniform Traffic Studies \(MUTS\)](#) provides additional guidance on conducting individual pedestrian walking speed studies.

- (5) Conducting field observations and safety improvement evaluations after LPI implementation is recommended, and potential further adjustments in signal timing and coordination may be applied based on safety needs and engineering judgment.

### 3.11.5 LPI CONSIDERATIONS

- (1) When an LPI is used, consideration should be given to turning movements across the crosswalk during the LPI.
- (a) Protected left-turn

The LPIs shall not be timed with the opposing protected left turn interval. For opposing leading left-turn movement, the LPIs shall be timed prior to the green interval for through vehicle movements and after the opposing protected left-turn movement. For opposing lagging left-turn movement, the LPI shall also be timed prior to the green interval for through vehicle movements.

**(b) Permissive left-turn**

Opposing permissive left-turns may be timed concurrently with an LPI in either of the following conditions.

- When LPI is called on one of the pedestrian phase pair first and then the other, the LPI timing addition should not extend beyond four (4) seconds.
- The pedestrian phase pairs can also be tied together, either logically on the controller or physically in the controller cabinet.

Examples are illustrated in **Figure 3.11-1**.

**Figure 3.11-1. Schematic Diagram for Signal Timing with LPI**

**A - Lead/lead left-turn**

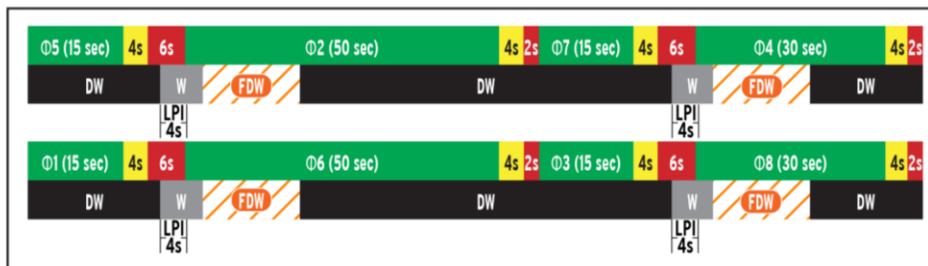

**B - Lead/lag left-turn**

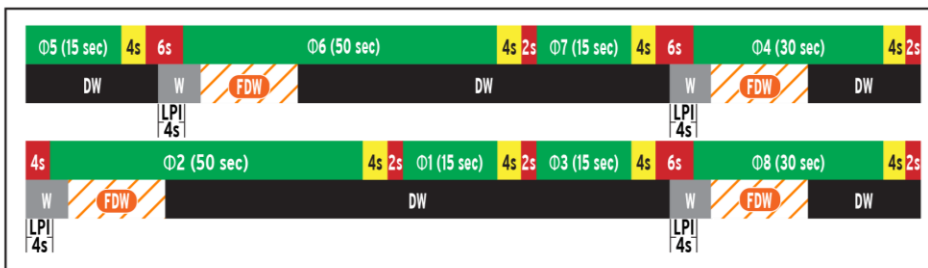

LEGEND					
<span style="color: green;">■</span>	Green Interval	<span style="color: red;">■</span>	Red Interval	<span style="background-color: grey;">■</span>	Walk Interval
<span style="color: yellow;">■</span>	Yellow Interval	<span style="background-color: black;">■</span>	Don't Walk Interval	<span style="background-color: orange; border: 1px dashed black;">■</span>	Flashing Don't Walk Interval

- (2) An electronic blank-out “NO TURN ON RED” sign (**R10-11**) or “TURNING VEHICLES STOP FOR PEDESTRIANS” sign (**R10-15a**) should be considered to enhance LPI implementation compliance.
- (3) Extended LPI should be considered at the following locations:
  - (a) Approaches with large portions of users with slower crossing speeds (children, older adults, persons with physical disabilities).
  - (b) At approaches where the pedestrian detector location is not immediately adjacent to the curb.
  - (c) If no pedestrian detector is present, a location six (6) feet from the face of the curb or from the edge of the pavement may be considered for calculating extended LPI.
- (4) The use of an Accessible Pedestrian Signal (APS) ([Sections 4E.09 to 4E.13 of the MUTCD](#)) should be considered if an LPI is used, as vision-impaired pedestrians use the sound of moving traffic to start crossing.
- (5) For marked school crossings, LPI should be implemented during the school arrival and departure time periods to meet the increased pedestrian demand. The crossing time period should coincide with the school zone time period as identified in the [Chapter 15 of the Department's Speed Zoning Manual](#).
- (6) Lengthy traffic signal cycles should be avoided to reduce pedestrian wait times and increase pedestrian compliance behavior with pedestrian signals.
- (7) In the following signal timing scenarios, LPI can increase vehicle or pedestrian delay.
  - (a) Coordinated system where the through movement is resting in walk
  - (b) Pretimed system
  - (c) Automatic pedestrian recall

If implemented, LPI should only be considered for times and days in where there are pedestrians present. The engineer should review each signal/corridor and controller type prior to recommending the decision. Special considerations need to be made when no to little pedestrian activity is expected, e.g., a C2T intersection at 3 AM.
- (8) To have LPI only when a pedestrian activates a pushbutton, the parameters for “pedestrian recall” and “REST IN WALK” on the controller cannot be configured.
- (9) At locations where the controller does not support LPI programming, the engineer may recommend not to implement LPI.

- (10)** The red revert interval is a safety feature and only applicable for actuated traffic signal control. This mode is used at locations where side street pedestrian, bike and vehicle volumes are low and infrequent for most of the day in comparison to heavier volumes on the main street. It only occurs when a side street vehicle or bicycle moves off the detector during the amber or red clearance time prior to receiving their green indication.

PROCEDURE



SIGNS



SIGNALS



MARKINGS



SPECIAL  
OPERATIONAL  
TOPICS



## Section 4.1

### CROSSWALKS IN HEAVY PEDESTRIAN CONCENTRATION AREAS

#### 4.1.1 GENERAL

Heavy pedestrian generators such as beaches or hotels may create a need for channeling pedestrians across a State Highway at locations other than intersections.

To help ensure the use of marked crosswalks in heavy pedestrian concentration areas, special consideration should be given to their location relative to construction or proximity of sidewalks, paths, guardrails, retaining walls, or shrubbery as a means for controlling existing pedestrian crossing movements within a defined path.

#### 4.1.2 MARKINGS

- (1) A marked crosswalk shall consist of 2 parallel white lines 1-foot wide. Lines should be placed not less than 6 feet apart and located to provide the least amount of walk time, whenever practical (see the [Standard Plans, Indexes 522-002 and 711-001](#)).
- (2) For added visibility, special emphasis markings may be used as shown in the [Standard Plans, Index 711-001](#).

#### 4.1.3 SIGNING

- (1) A PEDESTRIAN CROSSING (**W11-2**) sign, along with an arrow panel (**W16-7p**) shall be installed immediately adjacent to each marked pedestrian crossing location. This installation can be either ground-mounted or overhead on the mast arm or span wire.
- (2) A PEDESTRIAN CROSSING (**W11-2**) sign along with an AHEAD (**W16-9P**) supplemental panel shall be installed in advance of a series of marked crosswalks and may be installed in advance of each crosswalk location within a heavy pedestrian concentration area.
- (3) The need for advance crossing signs shall be based on engineering judgment considering relative spacing of crosswalks, roadside development, and other factors. The [Standard Plans, Index 711-001](#) shall be used for mounting locations as related to approach speeds.
- (4) An END PEDESTRIAN CROSSING sign may be installed to notify motorists that the pedestrian zone has ended. The sign should be 3 x 8 feet with 8-inch letters if mounted overhead. The size of a ground-mounted sign shall be 24 x 30 inches.

Sign format shall be similar to that used for the END SCHOOL ZONE (***FTP-32-04*** or ***FTP-34-04***) sign as shown in the [\*Department's Speed Zoning Manual\*](#). The sign should be installed approximately 200 to 300 feet beyond the last marked crosswalk.

## Section 4.2

### PAVEMENT WORD, SYMBOL, AND ARROW MARKINGS

#### 4.2.1 GENERAL

- (1) Pavement word, symbol, and arrows markings (**Figure 4.2-1** through **Figure 4.2-2**) may be used to supplement existing highway signing and/or to provide additional emphasis for regulatory, warning, or guidance messages as determined by engineering judgment.

**Figure 4.2-1. Pavement Word Markings**



- (2) The minimum requirements for word, symbol, and arrow markings are provided in [Section 3B.20 of the MUTCD](#). Additional requirements are provided in the [Department's Speed Zoning Manual](#), [Standard Plans](#), [Indexes 711-001 and 711-002](#). Route shields shall be designed in accordance with [Standard Plans](#), [Index 711-001](#).
- (3) Pavement word, symbol, and arrow markings shall not be used as a substitute for vertical sign installation unless overhead signing is impractical or impossible to install, such as when imposing on navigable airspace.
- (4) To recommend non-standard word or symbol pavement markings, an engineering study indicating how the application can be expected to optimize operations efficiency and/or safety is required to be forwarded through the

[District Traffic Operations Engineer \(DTOE\)](#) to the [State Traffic Operations Engineer \(STOE\)](#) in support of a FHWA Request for Experiment. If the request is accepted and approved by the FHWA, the [District Traffic Operations Office](#) recommending the design will be responsible for submission of the required interim and final reports to Central Office for review and submission to the FHWA.

**Figure 4.2-2. Pavement Symbol and Arrow Markings**



#### **4.2.2 LANE USE ARROW AND “ONLY” PAVEMENT MARKINGS ON INTERSECTION APPROACHES**

- (1) Lane-use arrow symbols should not be routinely applied in through lanes at intersections except with overhead lane-use control signs. However, where unusual geometrics or alignment of through lanes may result in driver confusion, a straight arrow symbol may be used to provide additional guidance for drivers in the through lanes.
- (2) The word “ONLY” is not required if the arrow symbol for an exclusive turn lane is used under the following conditions:
  - (a) Lane is developed at a mid-block location.
  - (b) Lane is clearly delineated by appropriate channelization.
  - (c) Lane requires lateral vehicle movement from an established lane for

proper positioning to execute the turn.

- (3) However, the word “ONLY” shall be used with the arrow symbol where unusual geometrics or alignment of an exclusive turn lane may result in driver confusion or misunderstanding.
- (4) Where an established through lane becomes an exclusive turn lane, the word “ONLY” shall be used with the arrow symbol indicating the allowed turning movement.
- (5) Whenever the word “ONLY” is used with an arrow symbol, these markings shall be accompanied by the appropriate signs as specified in [Section 2B-18](#), [Section 2B-19](#), [Section 2B-20](#), and [Section 3B-20 of the MUTCD](#).
- (6) Design and placement details for pavement arrows and the ONLY message are found in the [Standard Plans, Index 711-001](#).

### 4.2.3 ROUTE SHIELD PAVEMENT MARKINGS

- (1) Route Shield Pavement Markings (**Figure 4.2-3**) shall be justified for use due to cost. Coordination with the District Maintenance Office is required prior to approving the use. Public feedback about a specific location should be considered. Route shield pavement markings are justified for each of the following conditions:
  - (a) Increased crash history where high traffic volumes worsen complex lane assignments such as lane drops, double lane exits with optional lanes, gores where crash cushions are hit frequently, and unusual geometries.
  - (b) Underutilization of the optional lane or excess lane where changing maneuvers could cause congestion in an area not expected from volume/capacity analyses.
  - (c) Complicated lane assignments and alignment shifts.
  - (d) Where an overhead sign structure is not practical and the turn-lane from an arterial to the on-ramp of a limited access facility may appear to provide access to establishments in the vicinity.

**Figure 4.2-3. Route Shield Pavement Markings**

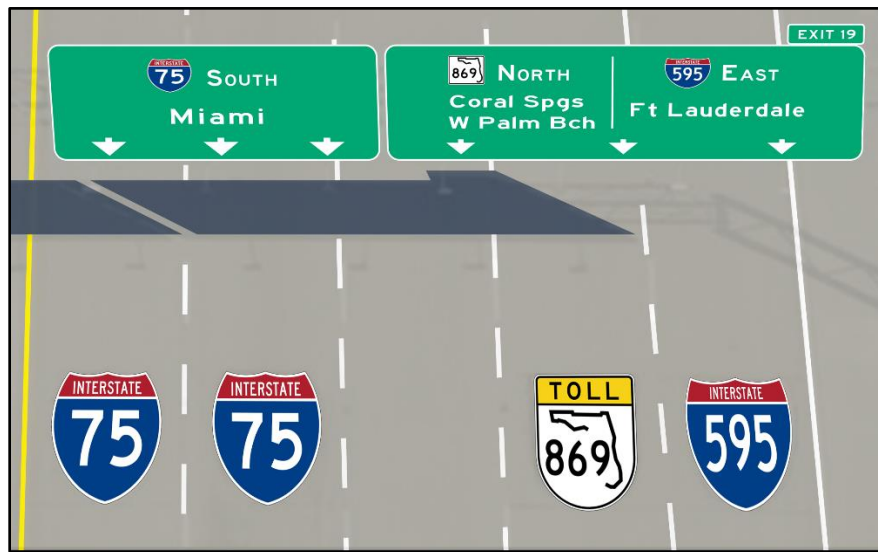

- (2) Route shield pavement markings are to be installed for optimum visibility.
  - (a) Place after at least one overhead guide sign for interchange.
  - (b) Place far enough upstream of the decision point to allow motorist to safely change lanes.
  - (c) Do not install under or immediately adjacent to overpasses as they can cast shadows on the shields. Note that placement on downhill slopes may reduce their effectiveness.
  - (d) Place no more than two sets of markings (shield, with arrow or message) before the gore or decision point.
  - (e) Install them within 1 mile in advance, taking into consideration existing signs and other traffic control devices.
- (3) Route shield pavement markings shall be installed as follows:
  - (a) Shall be pre-formed thermoplastic.
  - (b) Shall be 20 feet for limited access roadways, and 15 feet for arterials and collectors in length.
  - (c) Align the symbol in the center of the lane.
  - (d) In a single line across the roadway. Do not stagger.
  - (e) Arrows or messages (TO, LEFT, RIGHT, NORTH, SOUTH), may be used

to supplement route shields and shall follow the route shield.

- (f) Use an 80-foot gap between markings. However, cardinal directions (if used) may be 40 foot from a route shield marking.

**Figure 4.2-4. Cardinal Direction Markings**



#### 4.2.4 ROUTE SHIELDS FOR WRONG WAY TREATMENT

- (1) Route shield pavement markings provide proper guidance to motorists on arterials adjoining limited access facilities. **Figure 4.2-5** and **Figure 4.2-6** show the plan view of the E Bearss Avenue interchange with Interstate-275 in Tampa. **Figure 4.2-6** shows the left turn arrow marking in the westbound dual left turn lanes east of the off-ramp intersection. These figures illustrate the possible existing typical treatments and, if present, will need modifications as noted in this section. Such treatments shall not be used on future projects.

**Figure 4.2-5. Plan View of an I-275 Interchange**

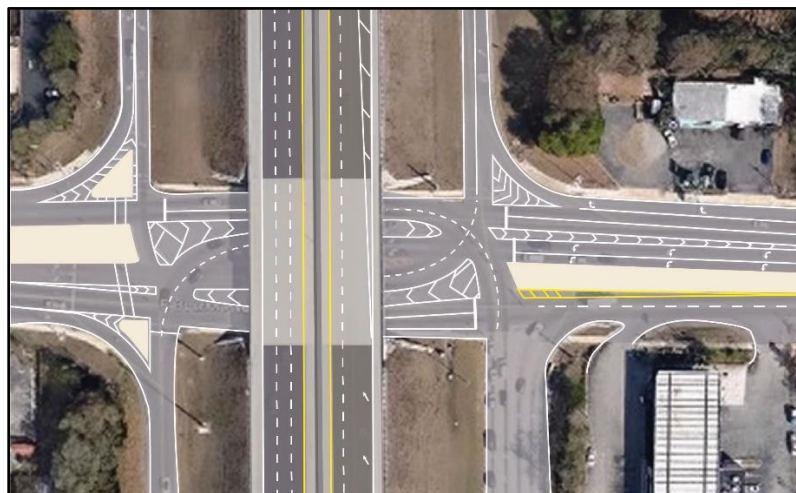

**Figure 4.2-6. Dual Left Turn Lanes with Left Turn Arrows**

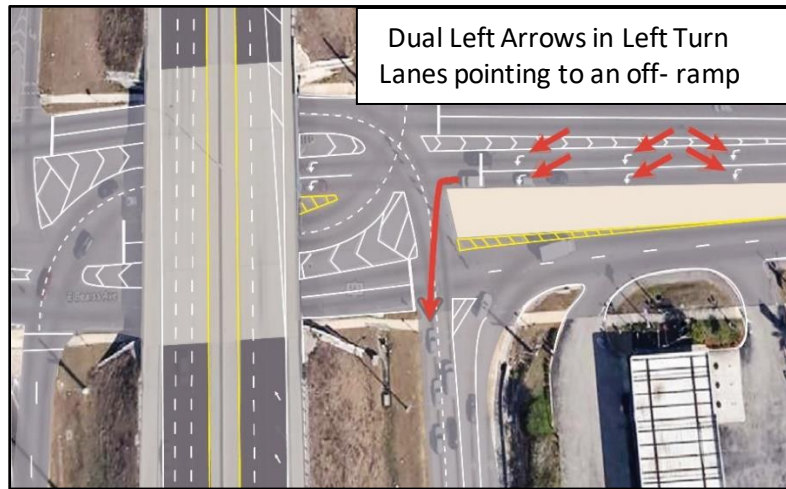

- (2) At interchanges with a break in the arterial left turn lane(s) serving a ramp, the pavement markings preceding the break shall include the interstate shield, cardinal direction, and straight arrow. An example is shown in **Figure 4.2-7**.

**Figure 4.2-7. Pavement Markings for Wrong Way Treatment**



- (3) There shall be one combination of the interstate shield, cardinal direction and straight arrow per lane and preceding the break in the turn lane which then serves the entry ramp.
- (4) The lane designation at all newly designed interchanges shall follow this scheme.

## Section 4.3

# USE OF BLUE RAISED PAVEMENT MARKERS TO IDENTIFY FIRE HYDRANTS

Section rescinded. Requirements can now be found in [Standard Plans, Index 706-001](#).